



Contents

create

New Products Feature	2 - 5
Glass Whiteboards and Easels	6 - 9
Frameless Whiteboards	10 - 15
Aluminium Framed Whiteboards	16 - 18
Eco-Friendly Whiteboards	19
Shield® Whiteboards	20 - 21
Mobile Whiteboards	22 - 26
Printed Whiteboards	27 - 32
Whiteboard Accessories	33 - 37
Flipchart Easels	38 - 41
Flipchart Accessories	42
Trapease® Paper Hanger	43
BusyRail® Sliding Rail	44 - 45

inform

Unframed Noticeboards	46 - 49
Aluminium Framed Noticeboards	50 - 53
Eco-Friendly® Noticeboards	54 - 57
Shield® Noticeboards	58 - 61
Dual Noticeboards	62 - 63
Tamperproof Noticeboards	64 - 69
Shield® Tamperproofs	70 - 73
Shield® Showcases	74 - 82
Freestanding Noticeboards	83 - 85
Poster Frames	86 - 89
Freestanding Poster Frames	90 - 94
Writing Signs	95 - 97
In-Out Boards	98 - 99
Graphic Signage	100 - 103

inspire

Panorama Literature Display	104 - 105
Revolving Literature Display	106 - 107
Acrylic Literature Display	107 - 111
Shelf Literature Display	112 - 115
Wave Literature Display	116 - 117
Mesh Literature Display	118 - 119
Steel Literature Display	120 - 121
Wire Literature Display	122 - 123
Wood Literature Display	124 - 125

exhibit

BusyFold® Display Systems	126 - 131
MightyBoard Display Systems	132 - 133
OnBoard® Pole and Panel Display	134
Grandstand Pole and Panel Display	135
MultiBoard Pole and Panel Display	136
Barrier Systems	137
BusyScreen® Partitions	138 - 142
Coat Stands and Hooks	143 - 144
Clocks	145
Glazed Display Cases	146 - 147

furnish

Meeting Room Tables	148 - 149
Folding Tables	150 - 151
Chairs	152
Lecterns	153 - 155
TV Stand	156
Projector Stands	157
Projector Cabinets	158 - 159

engage

Freestanding Projection Screens	160 - 164
Tabletop Projection Screen	165
Manual Projection Screens	166 - 167
Electric Projection Screens	168 - 175
Projection Screen Accessories	176
Frame Projection Screens	177
Whiteboard Projection Screens	178 - 181

educate

Laptop Whiteboards	182
Junior Easels	183 - 186
Junior Role Play Furniture	187 - 189
Junior Storage Units	190 - 191
ColourBox® Tray Storage	192 - 197
ColourBox® Tub Storage	198 - 199
ColourBox® Book Storage	200 - 201
ColourBox® Storage Cabinets	202 - 203
ColourBox® Quadrant Storage	204
ColourBox® Cloakroom Storage	205
Junior Partition Screens	206 - 207

NEW Eco-Colour Resist-a-Flame® Noticeboards

You can't put a price on safety or peace of mind
Our new Eco-Colour® boards offer an affordable
solution to fire resistant noticeboards.

Eco-Colour® pinnable board offers no powdery
residue and is made from 'Recycled' material

with both 'Fire Resistant' (to BS EN 1350 Class B)
and 'Acoustic Properties' - making it ideal for use
within busy public spaces, learning and office
environments.

Fire resistant - BS EN 13501 Class B
Made from recycled materials
Acoustic properties - up to NRC 0.8
Self-coloured pinnable core
Choice of 11 colours - so far!



ECO-COLOUR® BOARDS COLOUR RANGE





Frameless Noticeboards

Can be mounted portrait or landscape.
Mounts through the board with capped fixings.

Go to page **48**



Aluminium Framed Noticeboards

Anodised aluminium frame with concealed corner fixings.
Can be mounted portrait or landscape.

Go to page **52**



EF Noticeboards

Eco-Friendly noticeboard frame made from timber industry bi-product.
Can be mounted portrait or landscape.
Not fire resistant.

Go to page **56**



Shield® Tamperproof Noticeboards

Deluxe tamperproof noticeboard range compliments the new Eco-Colour® board range.

Go to page **72**



Tamperproof Noticeboards

Boards and covers conform to the latest BS.EN specification - but for a substantial cost saving if you choose Eco-Colour®

Go to page **66**



NEW Shield® light oak effect boards

Popular Shield® range is now available in a stunning light oak wood effect frame finish. Traditional yet contemporary finish. Ideal for external as well as internal use. Just wipe clean without maintenance requirements of real wood!

Aluminium framework
Coordinated frame designs
Loop nylon fabric
Eco-Colour™ fire resistant
External options





Shield® Whiteboards

Now you can choose your whiteboards to match.

Go to page **20**



Shield® Tamperproof Noticeboards

Ideal for use with traditional decor.

Go to page **70**



Shield® Noticeboards

Lift the importance of your notices with a real wood look

Go to page **58**



Shield® Corridor Noticeboards

Recommended top hinge for corridors

Go to page **72**

Shield® Exterior Showcases

A perfect balance of traditional framing with vibrant pinboard colours

Go to page **80**





WriteOn® Glass Magnetic Whiteboards

The ultimate in contemporary drywipe presentations. Chrome mounts 'float' the board away from the wall. Available in a choice of 10 sizes up to 2.4 metres wide. The surface cleans easily with no ghosting. Made from toughened safety glass with a steel back. Accepts super strength neodymium magnets. Optional matching glass pen tray available.

Size	H 500mm W 500mm		
White	G5050/WH	£67.15	
Size	H 600mm W 450mm		
White	G4560/WH	£70.48	
Size	H 900mm W 600mm		
White	G6090/WH	£112.41	
Size	H 1000mm W 650mm		
White	G6510/WH	£135.50	

Size	H 1000mm W 1500mm		
White	G1015/WH	£241.72	
Size	H 1200mm W 900mm		
White	G9012/WH	£183.43	
Size	H 1200mm W 1800mm		
White	G1218/WH	£304.43	
Size	H 1000mm W 2000mm		
White	G1020/WH	£326.52	

Size	H 1200mm W 1200mm		
White	G1212/WH	£232.81	
Size	H 1200mm W 2400mm		
White	G1224/WH	£423.50	
Pen tray			
Size	W 300mm D 100mm		
White	G5000	£12.21	

WriteOn® Whiteboard Pens

Wallet of 4 pens:

1 of each Black, Blue, Red, Green
439115 **£6.93**

Pack of 10 pens:

3 Black, 2 Blue, 3 Red, 2 Green
439116 **£13.77**

Self Adhesive Gridding Tape
and other accessories

See pages 33-36

COLOURED OPTIONS OF THE ABOVE
4 SIZES ARE AVAILABLE - SEE PAGE 97



NEW WriteOn® Glass Flipchart Easel

1000 x 700mm glassboard.
 Steel backed to accept super strength magnets.
 White steel frame with black accent features.
 Manoeuvres on a star base with locking castors.
 Adjustable hook over flip pad hangers.
 Full width aluminium pen tray.

Board Size 1000 x 700mm
 Max Height 1850mm
 Weight 21kg
 Easel **441070**
£275.00

WriteOn® Flipchart Pads

Pack of 5 Pads

450010 **£27.89**

For other accessories please see pages 42

WriteOn® Whiteboard Pens

Wallet of 4 pens:

1 of each Black, Blue, Red, Green

439115 **£6.93**

Pack of 10 pens:

3 Black, 2 Blue, 3 Red, 2 Green

439116 **£13.77**

Self Adhesive Gridding Tape
 and other accessories

See page 33-36

FULL WIDTH PEN TRAY



ADJUSTABLE PAD HANGERS



HEIGHT ADJUSTABLE





WriteOn® Glass Revolving Whiteboards

1200 x 900mm double sided glassboard.

Board tilts and locks into the desired position.

Steel core to accept super strength magnets.

White steel frame with black accent features.

Manoeuvres on sturdy feet with locking castors.

Optional hook over flip pad hangers.

OPTIONAL FLIP PAD USE



TILTS TO AID WRITING



FULL WIDTH PEN TRAY



LOCKING TILT MECHANISM





Board Size 1200 x 900mm
 Height 1800mm
 Weight 40kg
 Easel **441290**
£499.00

WriteOn® Flipchart Pads

Pack of 5 Pads

450010 **£27.89**

For other accessories please see pages 42

WriteOn® Whiteboard Pens

Wallet of 4 pens:

1 of each Black, Blue, Red, Green

439115 **£6.93**

Pack of 10 pens:

3 Black, 2 Blue, 3 Red, 2 Green

439116 **£13.77**

Self Adhesive Gridding Tape
 and other accessories

See page 33-36

Writeon®



1. Function over form

make a product useful, above all else

2. Empathy and focus

truly understand the customers needs

3. Aim for 'WOW'

the "wow" is shorthand for a powerful, visceral reaction

4. 'Form and function are one'

form and function should be one, joined in a spiritual union

5. Deconstructivism

destroying all traditions and rebuilding things in your own vision

6. Simplicity

strip things down to their essential purpose

WriteOn® Colour Edged Whiteboards

Attractive frameless design with tough ABS colour edging.

Adds a modern accent to an everyday product.

Mounts flush to the wall with simple through the board fixings.

Edged in a choice of 6 bright colours with matching screw caps.

Double sided whiteboard, one side plain.

Faint Guideline® grid to aid writing on the reverse.

Low profile 2mm edging.

Mount white units side by side virtually seamlessly - see over.

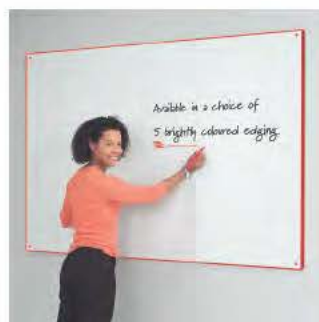

WriteOn® Whiteboard Pens

Wallet of 4 pens:

1 of each Black, Blue, Red, Green

439115 £6.93

Pack of 10 pens:

3 Black, 2 Blue, 3 Red, 2 Green

439116 £13.77

Self Adhesive Gridding Tape
and other accessories

See page 33-36



Size	H 600mm		
	W 900mm		
White	49332/WH	£35.75	
Black	49332/BK	£35.75	
Blue	49332/BL	£35.75	
Red	49332/RD	£35.75	
Yellow	49332/YW	£35.75	
Green	49332/GR	£35.75	



Size	H 900mm		
	W 1200mm		
White	49343/WH	£51.08	
Black	49343/BK	£51.08	
Blue	49343/BL	£51.08	
Red	49343/RD	£51.08	
Yellow	49343/YW	£51.08	
Green	49343/GR	£51.08	



Size	H 1200mm		
	W 1200mm		
White	49344/WH	£61.08	
Black	49344/BK	£61.08	
Blue	49344/BL	£61.08	
Red	49344/RD	£61.08	
Yellow	49344/YW	£61.08	
Green	49344/GR	£61.08	

Please note these boards are frameless so sizes shown are nominal



Size	H 1200mm		
	W 1500mm		
White	49354/WH	£79.92	
Black	49354/BK	£79.92	
Blue	49354/BL	£79.92	
Red	49354/RD	£79.92	
Yellow	49354/YW	£79.92	
Green	49354/GR	£79.92	

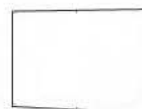

Size	H 1200mm		
	W 1800mm		
White	49364/WH	£98.41	
Black	49364/BK	£98.41	
Blue	49364/BL	£98.41	
Red	49364/RD	£98.41	
Yellow	49364/YW	£98.41	
Green	49364/GR	£98.41	



Size	H 1200mm		
	W 2400mm		
White	49384/WH	£116.98	
Black	49384/BK	£116.98	
Blue	49384/BL	£116.98	
Red	49384/RD	£116.98	
Yellow	49384/YW	£116.98	
Green	49384/GR	£116.98	





WriteOn® Whiteboard Wall

Create a continuous drywipe whiteboard wall.

Tough ABS edged whiteboards mount flush to the wall and each other due to their frameless design.

Simple through the board fixing.

White cover caps mask the fixings.

This double sided whiteboard features one side plain with a feint Guideline® grid to aid writing on the reverse.

6 standard sizes, special sizes available - ask for a quote.

Suggested multiple boards available as kits.

INDIVIDUAL WHITEBOARDS



Size H 578mm
W 876mm
Code **59332**
£35.75



Size H 876mm
W 1176mm
Code **59343**
£51.08

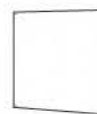

Size H 1176mm
W 1176mm
Code **59344**
£61.08



Size H 1176mm
W 1476mm
Code **59354**
£79.92



Size H 1176mm
W 1779mm
Code **59364**
£98.41

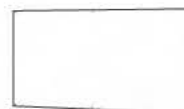

Size H 1176mm
W 2376mm
Code **59384**
£116.98



used in
must be
ation and
on time

Each operation in
the production flow
must be carefully
defined - and
recorded in detail

The output from
each stage of
the flow must
conform to quality
standards

The achievement
of a successful
production flow line
requires considerable
planning



MULTIPLE WHITEBOARDS KITS



Size H 1476mm
W 3528mm
Code 3 x **59354**
£239.76

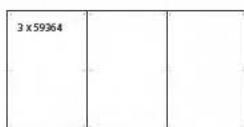

Size H 1779mm
W 3528mm
Code 3 x **59364**
£295.23

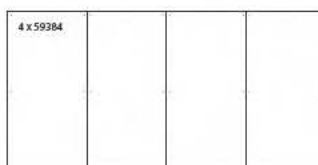

Size H 2376mm
W 4704mm
Code 4 x **59384**
£467.92

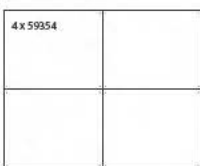

Size H 2352mm
W 2952mm
Code 4 x **59354**
£319.68

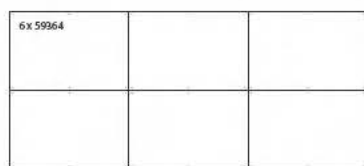

Size H 1779mm
W 5880mm
Code 6 x **59364**
£590.46

WriteOn® Whiteboard Pens

Wallet of 4 pens:
1 of each Black, Blue, Red, Green
439115 **£6.93**

Pack of 10 pens:
3 Black, 2 Blue, 3 Red, 2 Green
439116 **£13.77**

Self Adhesive Gridding Tape
and other accessories
See pages 33-36



What is the purpose of a sales forecast?

What are the methods of sales forecasting?

What is the meaning of sales projection?



So how do you do a financial forecast?



WriteOn® Frameless Magnetic Whiteboards

- Create a continuous drywipe whiteboard wall.
- Mount flush to the wall.
- Ingenious button-fix™ mounting system for mounting portrait or landscape.
- Coated steel surface bonded to multi layered wood backing.
- 2 standard sizes.
- Boards butt seamlessly to create continuous runs on flat walls.

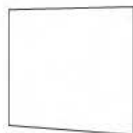

Size H 1000mm
W 1200mm
Code **41012**
£400.00

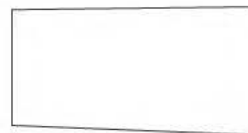

Size H 1000mm
W 2400mm
Code **41024**
£725.00

SET THE REAR FIXINGS FOR PORTRAIT OR LANDSCAPE MOUNTING



MOUNT THE BUTTON FIXINGS



BOARD MOUNTS FLUSH



WriteOn® Flipchart Pads

Pack of 5 Pads
450010 **£27.89**
For other accessories please see pages 42

WriteOn® Whiteboard Pens

Wallet of 4 pens:
1 of each Black, Blue, Red, Green
439115 **£6.93**

Pack of 10 pens:
3 Black, 2 Blue, 3 Red, 2 Green
439116 **£13.77**

Magnetic Gridding Tape,
Self Adhesive Gridding Tape
and other accessories

See page 33-36



WriteOn® Magnetic Flip Pad Holder

Rear magnet adheres to any steel surface.

Holds any pre-drilled A1 flipchart pad.

Sprung clamp neatly covers the mounting hooks.

Size H 55mm
W 665mm
D 30mm

Code **446002**
£31.14

WriteOn® Flipchart Pads

Pack of 5 Pads

450010 **£27.89**

For other accessories please see pages 42

WriteOn® Whiteboard Pens

Wallet of 4 pens:

1 of each Black, Blue, Red, Green

439115 **£6.93**

Pack of 10 pens:

3 Black, 2 Blue, 3 Red, 2 Green

439116 **£13.77**

Magnetic Gridding Tape,
Self Adhesive Gridding Tape
and other accessories

See page 33-36

October news letter

Brainstorm with John

Check system requirements

~~Prepare awards presentation~~

~~Book NY flight~~

Plan summer hols

WriteOn® Aluminium Framed Whiteboards

Aluminium framed whiteboards in a wide range of sizes.

Supplied with pen tray.

Concealed through the corner wall fixings.

For use with drywipe pens.

Can be mounted landscape or portrait.

3 drywipe surface options - Guideline®, Magnetic, VES.

Non-magnetic Guideline®

Double sided board.

One side ultrasmooth surface.

One side Guideline® 20mm grid.



Magnetic

Coated steel writing surface.

Accepts magnets.

Up to 3m wide.



Magnetic Vitreous Enamel Steel

Vitreous Enamel Steel surface.

Accepts magnets.

Surface guaranteed for 25 years.



Size H 450mm
W 600mm

Guideline® **47131** **£25.62**
Magnetic **49631** **£24.26**
VES **49431** **£41.58**



Size H 600mm
W 900mm

Guideline® **47132** **£36.26**
Magnetic **49632** **£34.26**
VES **49432** **£68.70**

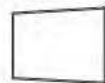

Size H 900mm
W 1200mm

Guideline® **47143** **£55.15**
Magnetic **49643** **£52.57**
VES **49443** **£108.08**

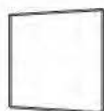

Size H 1200mm
W 1200mm

Guideline® **47144** **£61.29**
Magnetic **49644** **£66.55**
VES **49444** **£141.07**

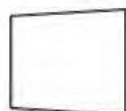

Size H 1200mm
W 1500mm

Guideline® **47154** **£77.10**
Magnetic **49654** **£97.43**
VES **49454** **£177.37**



Size H 1200mm
W 1800mm

Guideline® **47164** **£91.95**
Magnetic **49664** **£112.43**
VES **49464** **£208.22**



Size H 1200mm
W 2400mm

Guideline® **47184** **£133.31**
Magnetic **49684** **£134.15**
VES **49484** **£265.46**

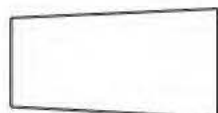

Size H 1200mm
W 2700mm

Guideline® **47194** **£145.17**
Magnetic **49694** **£169.40**
VES **49494** **£314.12**



Size H 1200mm
W 3000mm

Magnetic **49610** **£191.75**

WriteOn® Magnetic Flipchart Clamp

446002 **£31.14**

For details see page 15

WriteOn® Flipchart Pads

Pack of 5 Pads

450010 **£27.89**

For other accessories please see pages 42

WriteOn® Whiteboard Pens

Wallet of 4 pens:

1 of each Black, Blue, Red, Green

439115 **£6.93**

Pack of 10 pens:

3 Black, 2 Blue, 3 Red, 2 Green

439116 **£13.77**

Magnetic Gridding Tape,
Self Adhesive Gridding Tape
and other accessories

See page 33-36



WriteOn® Spacesaver Whiteboards



Opens up to 3 times the surface area.

Hinged double sided panels create additional writing areas.

Use for revealing pre-prepared work or covering confidential information.

Range of sizes, with single or double fold out panels.

Magnetic or non-magnetic surfaces.

Concealed corner fixings supplied.

Supplied with pen tray.

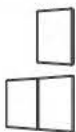

Closed H 900mm
W 600mm
Open H 900mm
W 1200mm

Laminate **BLB1000**
£100.61

Magnetic **BWB1000**
£124.99



Closed H 1200mm
W 900mm
Open H 1200mm
W 1800mm

Laminate **BLB1001**
£153.18

Magnetic **BWB1001**
£208.31

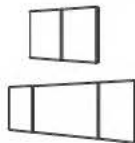

Closed H 900mm
W 1200mm
Open H 900mm
W 2400mm

Laminate **BLB1002**
£182.27

Magnetic **BWB1002**
£230.31

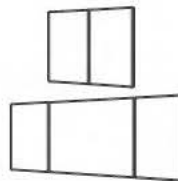

Closed H 1200mm
W 1500mm
Open H 1200mm
W 3000mm

Laminate **BLB1003**
£252.19

Magnetic **BWB1003**
£326.67

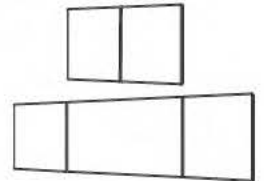

Closed H 1200mm
W 2000mm
Open H 1200mm
W 4000mm

Laminate **BLB1004**
£309.14

Magnetic **BWB1004**
£403.33

SINGLE FOLD OUT PANEL



DOUBLE FOLD OUT PANEL



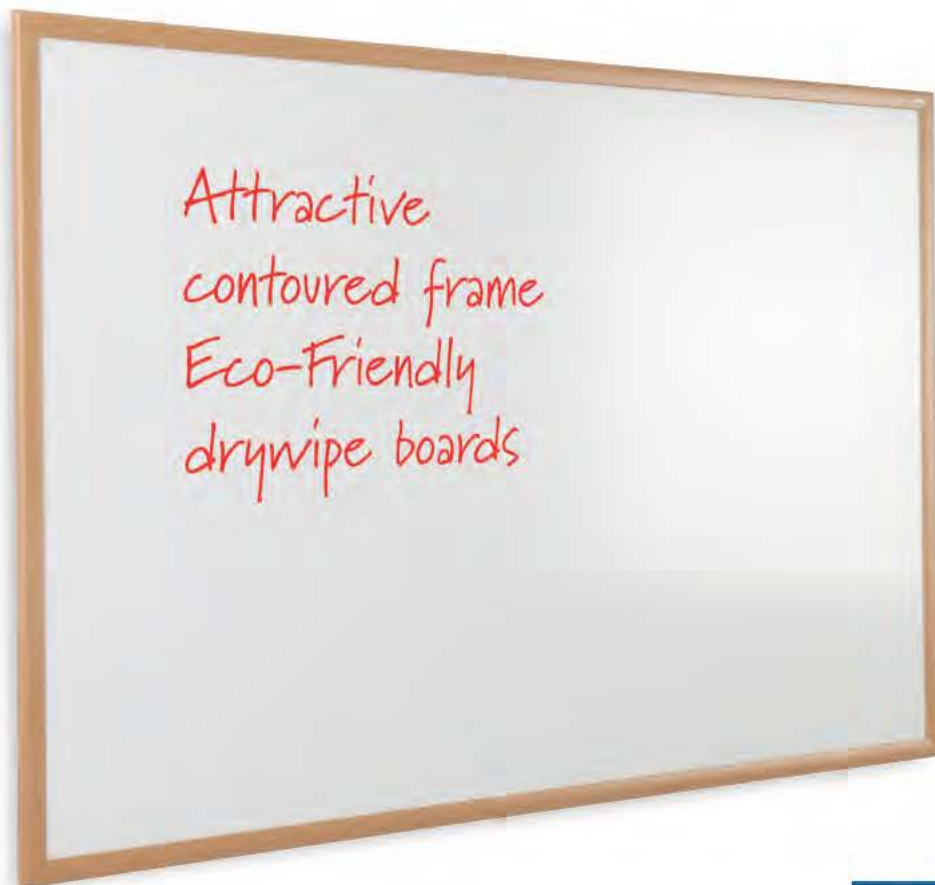

LIGHT OAK EFFECT



ALUMINIUM EFFECT



BLUE FRAME



BLACK FRAME



RED FRAME



WriteOn® EF Whiteboards



Environmental choice at an economical price.

Constructed from timber industry bi-products and recycled materials.

The attractive contoured 35mm wide frame is available in a choice of light oak effect, aluminium effect, blue, black or red finishes.

Boards can be mounted portrait or landscape with fixings provided.



Size	H 600mm		
	W 900mm		
Light oak	EFW9060/LO	£41.08	
Aluminium	EFW9060/AL	£41.08	
Blue	EFW9060/BL	£41.08	
Black	EFW9060/BK	£41.08	
Red	EFW9060/RD	£41.08	



Size	H 900mm		
	W 1200mm		
Light oak	EFW1290/LO	£57.42	
Aluminium	EFW1290/AL	£57.42	
Blue	EFW1290/BL	£57.42	
Black	EFW1290/BK	£57.42	
Red	EFW1290/RD	£57.42	



Size	H 1200mm		
	W 1200mm		
Light oak	EFW1212/LO	£69.92	
Aluminium	EFW1212/AL	£69.92	
Blue	EFW1212/BL	£69.92	
Black	EFW1212/BK	£69.92	
Red	EFW1212/RD	£69.92	



Size	H 1200mm		
	W 1500mm		
Light oak	EFW1512/LO	£88.83	
Aluminium	EFW1512/AL	£88.83	
Blue	EFW1512/BL	£88.83	
Black	EFW1512/BK	£88.83	
Red	EFW1512/RD	£88.83	

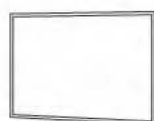

Size	H 1200mm		
	W 1800mm		
Light oak	EFW1812/LO	£100.17	
Aluminium	EFW1812/AL	£100.17	
Blue	EFW1812/BL	£100.17	
Black	EFW1812/BK	£100.17	
Red	EFW1812/RD	£100.17	

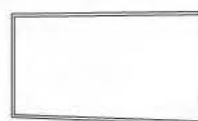

Size	H 1200mm		
	W 2400mm		
Light oak	EFW2412/LO	£130.67	
Aluminium	EFW2412/AL	£130.67	
Blue	EFW2412/BL	£130.67	
Black	EFW2412/BK	£130.67	
Red	EFW2412/RD	£130.67	

WriteOn® Whiteboard Pens

Wallet of 4 pens:

1 of each Black, Blue, Red, Green

439115 £6.93

Pack of 10 pens:

3 Black, 2 Blue, 3 Red, 2 Green

439116 £13.77

Magnetic Gridding Tape,
Self Adhesive Gridding Tape
and other accessories

See pages 33-36





Shield® Aluminium Coloured Frame Whiteboards

Aluminium framed whiteboards available in 6 colours.

New Wood Effect frame options are di-sub printed aluminium, so very durable.

Range of 7 sizes up to 2.4m wide.

Concealed through the corner wall fixings.

For use with drywipe pens.

Can be mounted landscape or portrait.

2 drywipe surface options - Guideline® or Magnetic.

GUIDELINE®

Guideline® features a 20mm feint grid.

MAGNETIC

Coated steel writing surface, which also accepts magnets.



ALUMINIUM FRAME



NEW - WOOD EFFECT FRAMES



COLOURED FRAMES



Size H 450mm
W 600mm

Guideline®

Aluminium	SW31/AL	£40.86
Coloured	SW31/**	£56.42
Wood	SW31/LO	£48.17



Size H 600mm
W 900mm

Guideline®

Aluminium	SW32/AL	£52.21
Coloured	SW32/**	£71.58
Wood	SW32/LO	£55.89

Magnetic

Aluminium	SWM32/AL	£60.45
Coloured	SWM32/**	£83.26
Wood	SWM32/LO	£65.89



Size H 900mm
W 1200mm

Guideline®

Aluminium	SW43/AL	£71.42
Coloured	SW43/**	£96.75
Wood	SW43/LO	£86.07

Magnetic

Aluminium	SWM43/AL	£87.12
Coloured	SWM43/**	£113.96
Wood	SWM43/LO	£92.38



Size H 1200mm
W 1200mm

Guideline®

Aluminium	SW44/AL	£81.42
Coloured	SW44/**	£111.08
Wood	SW44/LO	£96.69

Magnetic

Aluminium	SWM44/AL	£98.70
Coloured	SWM44/**	£127.47
Wood	SWM44/LO	£114.76

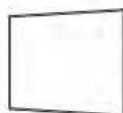

Size H 1200mm
W 1500mm

Guideline®

Aluminium	SW54/AL	£105.92
Coloured	SW54/**	£137.08
Wood	SW54/LO	£120.20

Magnetic

Aluminium	SWM54/AL	£123.88
Coloured	SWM54/**	£156.69
Wood	SWM54/LO	£138.44



Size H 1200mm
W 1800mm

Guideline®

Aluminium	SW64/AL	£127.00
Coloured	SW64/**	£158.17
Wood	SW64/LO	£141.93

Magnetic

Aluminium	SWM64/AL	£143.16
Coloured	SWM64/**	£175.79
Wood	SWM64/LO	£152.46



Size H 1200mm
W 2400mm

Guideline®

Aluminium	SW84/AL	£152.83
Coloured	SW84/**	£187.33
Wood	SW84/LO	£170.35

Magnetic

Aluminium	SWM84/AL	£171.05
Coloured	SWM84/**	£207.37
Wood	SWM84/LO	£180.18

** Please add code of colour required

** Please add code of colour required

** Please add code of colour required

WriteOn® Magnetic
Flipchart Clamp
446002 £31.14

For details see page 15

WriteOn® Flipchart Pads

Pack of 5 Pads

450010 £27.89

For other accessories please see page 42

WriteOn® Whiteboard Pens

Wallet of 4 pens:

1 of each Black, Blue, Red, Green

439115 £6.93

Pack of 10 pens:

3 Black, 2 Blue, 3 Red, 2 Green

439116 £13.77

Magnetic Gridding Tape,
Self Adhesive Gridding Tape
and other accessories

See pages 33-36

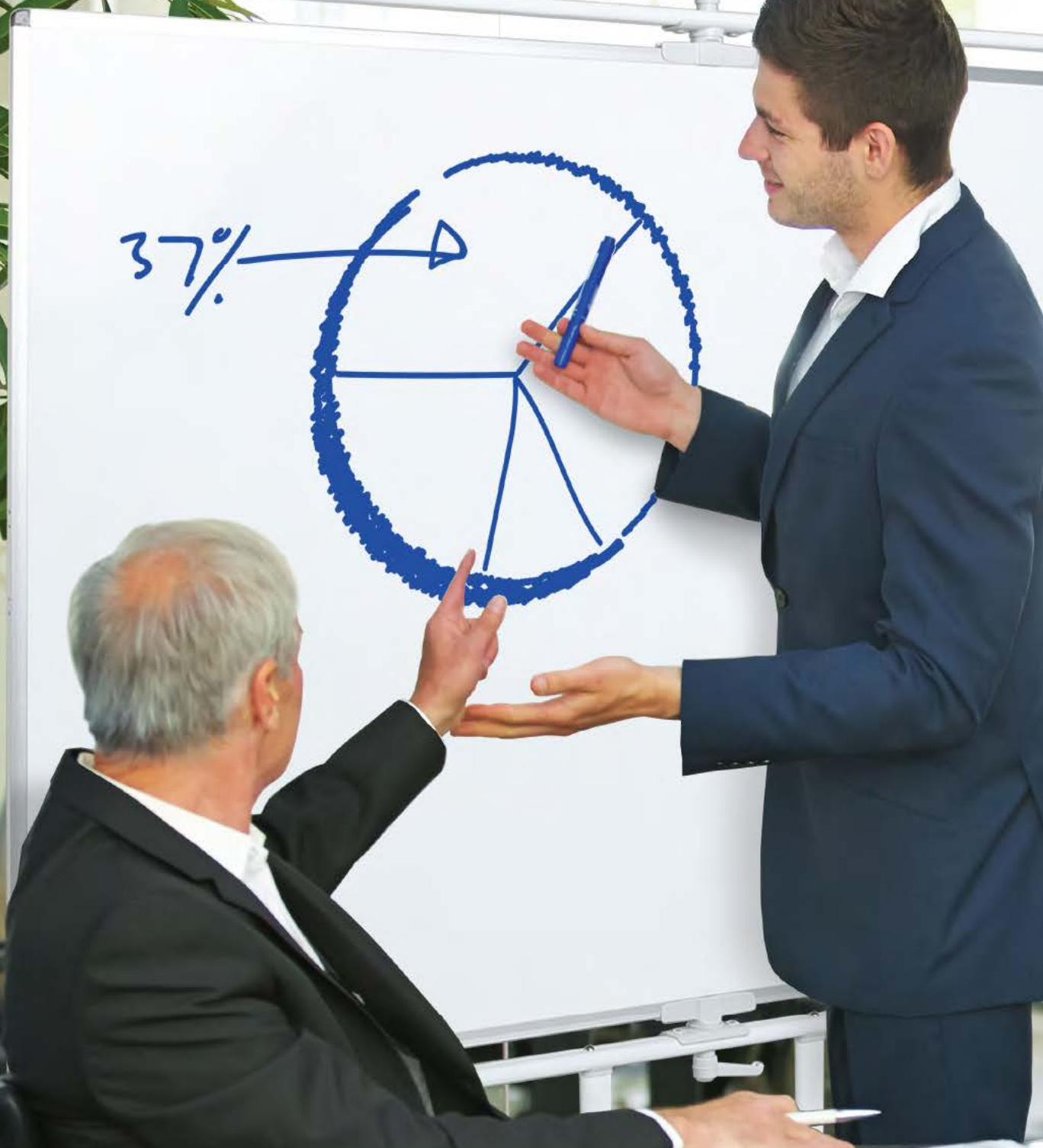

POSITIVE TILT LOCKING LEVER



FULL WIDTH PEN TRAY



STURDY LOCKING WHEELS



WriteOn® Revolving Whiteboards

Double sided whiteboard that can pivot to the desired angle.

Enables both surfaces to be angled towards the audience.

Range of 5 sizes up to 1.8m wide.

Simple self assembly.

For use with drywipe pens.

2 drywipe surface options - Guideline® or Magnetic.

Sturdy steel frame has 4 castors, 2 of which are locking.

Steel cross bars aid rigidity and house the supplied pen tray.

Guideline®

20mm feint grid one side,
plain on the other.

Magnetic

Coated steel writing surface,
which accepts magnets.

WriteOn® Revolver Rotates through horizontal axis - see bottom of page



Board Size H 900mm
W 1200mm

Guideline **447431** **£175.79**

Magnetic **447433** **£191.30**



Board Size H 1200mm
W 900mm

Guideline **447341** **£179.88**

Magnetic **447343** **£195.68**



Board Size H 1200mm
W 1200mm

Guideline **447441** **£197.87**

Magnetic **447443** **£219.33**



Board Size H 1200mm
W 1500mm

Guideline **447541** **£217.08**

Magnetic **447543** **£244.74**



Board Size H 1200mm
W 1800mm

Guideline **447641** **£245.71**

Magnetic **447643** **£289.39**

WriteOn® Writeangle Set up to rotate through horizontal or vertical axis - see opposite page



Board Size H 900mm
W 1200mm

Guideline **448431** **£212.18**

Magnetic **448433** **£245.99**



Board Size H 1200mm
W 900mm

Guideline **448341** **£216.27**

Magnetic **448343** **£250.71**



Board Size H 1200mm
W 1200mm

Guideline **448441** **£230.99**

Magnetic **448443** **£272.88**



Board Size H 1200mm
W 1500mm

Guideline **448541** **£251.02**

Magnetic **448543** **£301.19**



Board Size H 1200mm
W 1800mm

Guideline **448641** **£278.83**

Magnetic **448643** **£327.61**

WriteOn® Magnetic

Flipchart Clamp

446002 **£31.14**

For details see page 15

WriteOn® Flipchart Pads

Pack of 5 Pads

450010 **£27.89**

For other accessories please see pages 42

WriteOn® Whiteboard Pens

Wallet of 4 pens:

1 of each Black, Blue, Red, Green

439115 **£6.93**

Pack of 10 pens:

3 Black, 2 Blue, 3 Red, 2 Green

439116 **£13.77**

Magnetic Gridding Tape,
Self Adhesive Gridding Tape
and other accessories

See pages 33-36



Writeon®



WriteOn® Height Adjustable Mobile Whiteboards

Double sided mobile drywipe whiteboard panels.
Framed in anodised aluminium and mounted on sturdy white frame.
Locking castors for mobility.
Height adjustable panels can be mounted in portrait or landscape formats.
Double sided whiteboard features one side plain drywipe surface.
The reverse has a feint Guideline® grid to aid writing.
Matching pinnable option - see page 84.



HEIGHT ADJUSTMENT
IN 210mm INCREMENTS

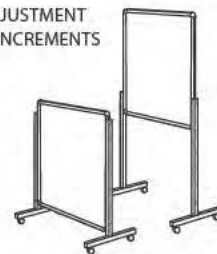

Board Size H 1200mm
W 900mm
Code **MWB43**
£160.18



Board Size H 1200mm
W 1200mm
Code **MWB44**
£170.53



Board Size H 1500mm
W 1200mm
Code **MWB54**
£188.95



Board Size H 1800mm
W 1200mm
Code **MWB64**
£201.40

WriteOn® Whiteboard Pens

Wallet of 4 pens:

1 of each Black, Blue, Red, Green

439115 **£6.93**

Pack of 10 pens:

3 Black, 2 Blue, 3 Red, 2 Green

439116 **£13.77**

Self Adhesive Gridding Tape
and other accessories

See pages 33-36



WriteOn

WriteOn® Wood Framed Mobile Whiteboards



A range of handmade beech framed boards.

Double sided drywipe whiteboards available in 3 sizes.

Features one side plain drywipe surface.

The reverse has a feint Guideline® grid to aid writing.

Made from quality lacquered beech sourced from sustainable forests.

Heavy duty wooden feet ensure stability when free standing; wheels are provided as standard; if mobility is required.

Matching pinnable option - see page 85.



Size H 1200mm
W 1200mm
Code **DJS44/WB**
£310.00

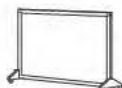

Size H 1200mm
W 1800mm
Code **DJS46/WB**
£363.06



Size H 1800mm
W 1200mm
Code **DJS64/WB**
£363.06

WriteOn® Whiteboard Pens

Wallet of 4 pens:

1 of each Black, Blue, Red, Green

439115 £6.93

Pack of 10 pens:

3 Black, 2 Blue, 3 Red, 2 Green

439116 £13.77

Self Adhesive Gridding Tape
and other accessories

See pages 33-36

WriteOn® Drywipe Foyer Boards

A drywipe whiteboard mounted portrait on an angled simple stand.
Ideal for displaying hand written information in foyer and reception areas.
White powder coated stand.
Mounted 900 x 600mm whiteboard with a finished height of 1800mm.

Board Size H 900mm
W 600mm
Stand Height 1800mm
Code **FWB32**
£168.58



Shield® Drywipe Foyer Boards

Deluxe framed whiteboard on a contemporary heavy duty aluminium stand.
This freestanding whiteboard can be mounted landscape or portrait.
Adjustable bracket enables the board to be mounted perpendicular or up to 45° angle.



Board Size H 600mm
W 450mm
Stand Height 1000mm
Aluminium **SFW005/AL**
£158.00



Board Size H 900mm
W 600mm
Stand Height 1000mm
Aluminium **SFW015/AL**
£172.83

WriteOn® Whiteboard Pens

Wallet of 4 pens:

1 of each Black, Blue, Red, Green

439115 **£6.93**

Pack of 10 pens:

3 Black, 2 Blue, 3 Red, 2 Green

439116 **£13.77**

Self Adhesive Gridding Tape
and other accessories

See page 33-36

WriteOn® Printed Modular Whiteboards

A range of printed whiteboards edged with 2mm low profile white edging. This frameless design enables the boards to be mounted side by side. The non-magnetic ultra smooth boards are all 1200mm x 1200mm. Available lined, gridded, handwriting lines, music staves or plain. Supplied with wall fixings.



Plain

Size H 1200mm
W 1200mm
Code **49344/WH**
£61.08



Please note these boards are frameless so sizes shown are nominal

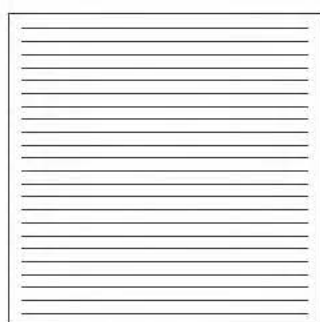

50mm lined

Size H 1200mm
W 1200mm
Code **46813**
£87.97

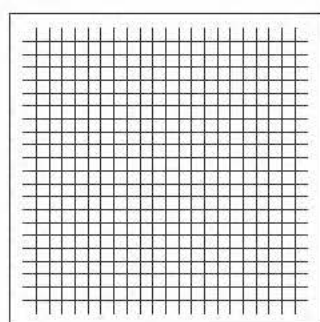

50 x 50mm gridded

Size H 1200mm
W 1200mm
Code **46814**
£87.97

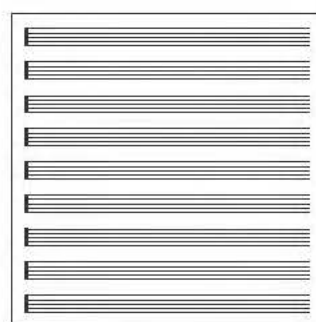

Music staves

Size H 1200mm
W 1200mm
Code **46815**
£91.53

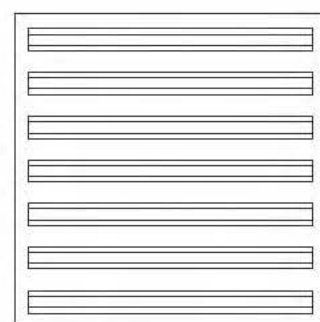

Handwriting

Size H 1200mm
W 1200mm
Code **46816**
£87.97



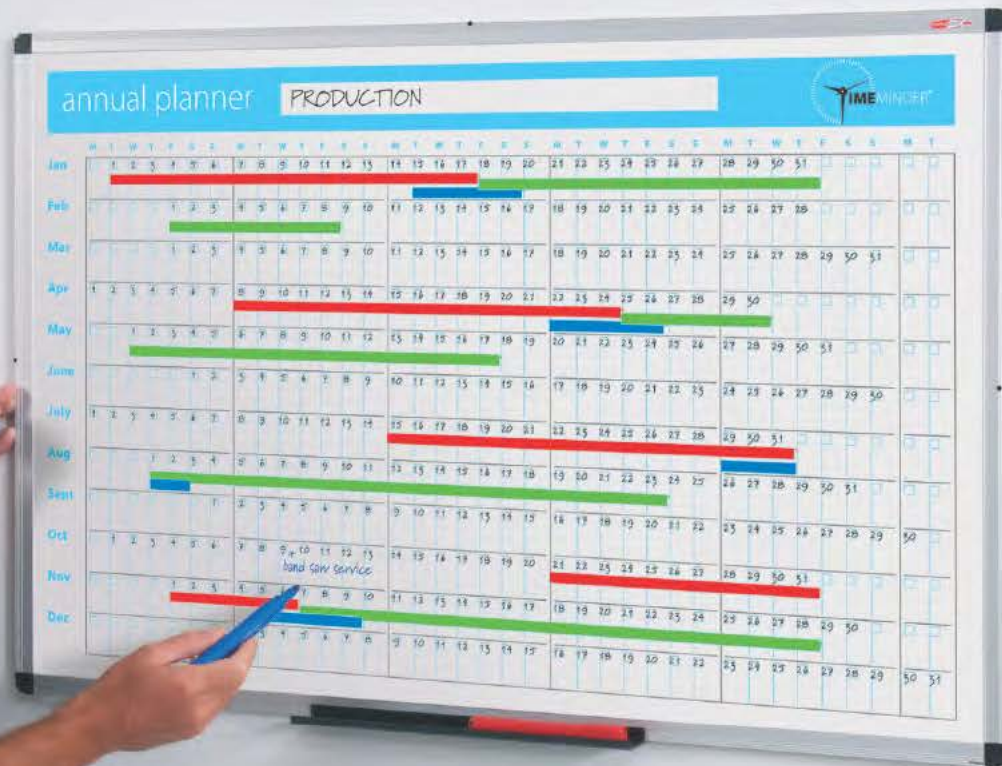

Timeminder® Drywipe Perpetual Planners

Undated planners that can be used time and time again.

Available in 5 variants to suit your needs.

Choice of 2 whiteboard frame styles.

BLUE COLOUR EDGED FRAMELESS DESIGN

Drywipe laminate non-magnetic surface for use with drywipe pens.

This sleek modern design is supplied with through the board fixings.

White caps conceal fixing.

ALUMINIUM FRAMED MAGNETIC

Drywipe coated steel version to accept magnets.

Supplied with through the corner fixings and pen tray.

For magnetic accessories see page 36.



BLUE COLOUR EDGED



ALUMINIUM FRAMED MAGNETIC



WriteOn® Whiteboard Pens

Wallet of 4 pens:

1 of each Black, Blue, Red, Green

439115 £6.93

Pack of 10 pens:

3 Black, 2 Blue, 3 Red, 2 Green

439116 £13.77

Magnetic Gridding Tape,
Self Adhesive Gridding Tape
and other accessories

See pages 33-36



24 Hour - 7 Day Planner

Size H 600mm
W 900mm

Blue colour edged
Non magnetic **46831**
£46.08

Aluminium framed
Magnetic **46841**
£54.37

Whiteboard Pens
Wallet of 4 pen **439115**
£6.93

Whiteboard Pens
Pack of 10 pens **439116**
£13.77

Week Planner

Size H 600mm
W 900mm

Blue colour edged
Non magnetic **46834**
£46.08

Aluminium framed
Magnetic **46844**
£54.37

Whiteboard Pens
Wallet of 4 pen **439115**
£6.93

Whiteboard Pens
Pack of 10 pens **439116**
£13.77

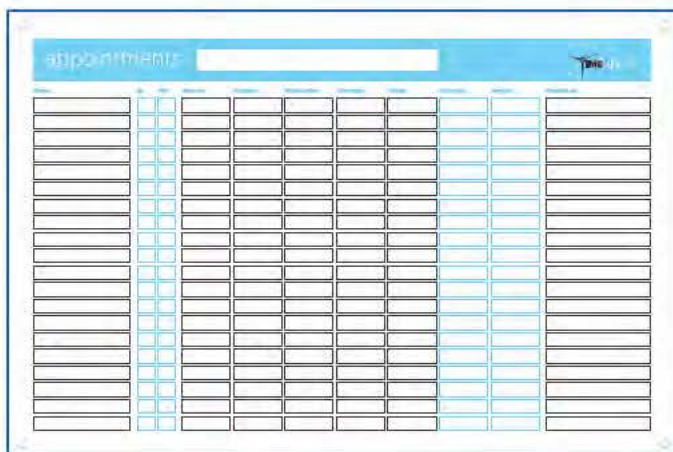
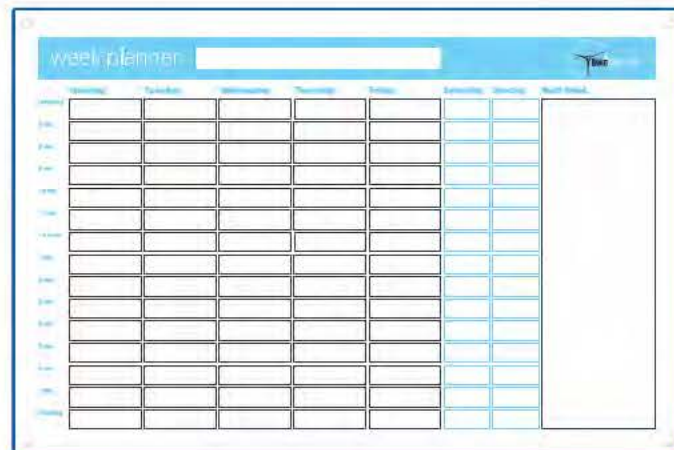

Appointments Planner

Size H 600mm
W 900mm

Blue colour edge
Non magnetic **46835**
£46.08

Aluminium framed
Magnetic **46845**
£54.37

Whiteboard Pens
Wallet of 4 pen **439115**
£6.93

Whiteboard Pens
Pack of 10 pens **439116**
£13.77

Month Planner

Size H 600mm
W 900mm

Blue colour edged
Non magnetic **46833**
£46.08

Aluminium framed
Magnetic **46843**
£54.37

Whiteboard Pens
Wallet of 4 pen **439115**
£6.93

Whiteboard Pens
Pack of 10 pens **439116**
£13.77



Annual Planner

Size H 600mm
W 900mm

Blue colour edged
Non magnetic **46832**
£46.08

Aluminium framed
Magnetic **46842**
£54.37

Whiteboard Pens
Wallet of 4 pen **439115**
£6.93

Whiteboard Pens
Pack of 10 pens **439116**
£13.77





WriteOn® Framed Drywipe Maps

Framed drywipe maps that accept magnets.

Mounted and framed maps with a drywipe surface.

Suitable for use with dry erase pens.

Choose from World, European, UK Postcode, UK Road and Terrain and UK County Boundary.

Supplied with wall fixings.



WORLD

Size H 1020mm
W 1460mm
Code **439166**
£240.42

EUROPEAN

Size H 1280mm
W 1020mm
Code **439167**
£221.14

UK POSTCODE

Size H 875mm
W 630mm
Code **439168**
£178.94

UK ROAD AND TERRAIN

Size H 1140mm
W 950mm
Code **439169**
£221.14

UK COUNTY BOUNDARY

Size H 1140mm
W 950mm
Code **439170**
£221.14





WriteOn® Tactical Sportsboards

Invaluable aid for teaching team sport tactics.
Drywipe boards printed with the pitch layout for
Football and Rugby Union.

Wall Mounted Magnetic

The 1200 x 900mm aluminium framed
whiteboards accept magnets and are supplied
with pen tray and wall fixings.
Convenient pack of 20 coloured magnetic disks
available in Blue and Red.

A3 Handheld

Handy for demonstrating tactics on the sideline.
A3 size boards have easy clean drywipe surface.
Sold as singles or packs of 10.

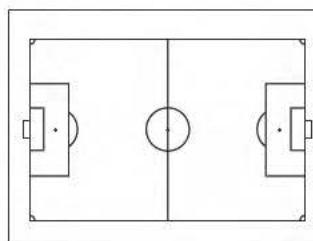

Football

Wall H 900mm
W 1200mm

Code **46806**
£78.77

Handheld H 297mm
W 420mm

Single **SB1**
£23.08
Pack of 10 **SB110**
£173.08

Magnets 30mm dia
20x Red **439153X2**
£13.77

20x Blue **439154X2**
£13.77

Not suitable for handheld boards

Other sports are available to special order

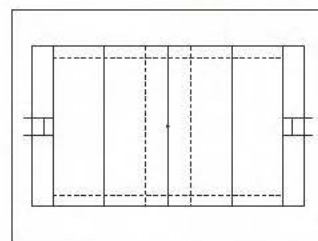

Rugby Union

Wall H 900mm
W 1200mm

Code **46809**
£78.77

Handheld H 297mm
W 420mm

Single **SB4**
£23.08
Pack of 10 **SB410**
£173.08

WriteOn® Whiteboard Pens

Wallet of 4 pens:

1 of each Black, Blue, Red, Green
439115 **£6.93**

Pack of 10 pens:
3 Black, 2 Blue, 3 Red, 2 Green
439116 **£13.77**

Other accessories
See pages 33-36

WriteOn® Drywipe Pen with NEW Ink Formula

New ink formula is now glassboard compatible.

These pens are ideal for all standard whiteboards and now, due to a new ink formula, can also be used on glassboards.

Quick drying, low odour and non-toxic. 6mm bullet tip.

Also non-bleed on flip pad paper.

Storage advice - store vertically, lid down.



Wallet of 4 pens

1 of each Black, Blue,
Red, Green

Code **439115**

£6.93

Box of 10 pens

3 x Black, 2 x Blue,
3 x Red, 2 x Green

Code **439116**

£13.77



Whiteboard Gridding Tape

Useful low profile tape for creating lines, grids or tables on a whiteboard surface.

Available in Black, Blue, Red, Green.

1.5mm, 3mm and 6mm widths.

Supplied on 16m roll.

1.5MM WIDE TAPE



Width	1.5mm	
Black	439300	£4.44
Red	439301	£4.44
Blue	439302	£4.44
Green	439303	£4.44

3MM WIDE TAPE



Width	3mm	
Black	439304	£4.82
Red	439305	£4.82
Blue	439306	£4.82
Green	439307	£4.82

6MM WIDE TAPE



Width	6mm	
Black	439308	£4.99
Red	439309	£4.99
Blue	439310	£4.99
Green	439311	£4.99

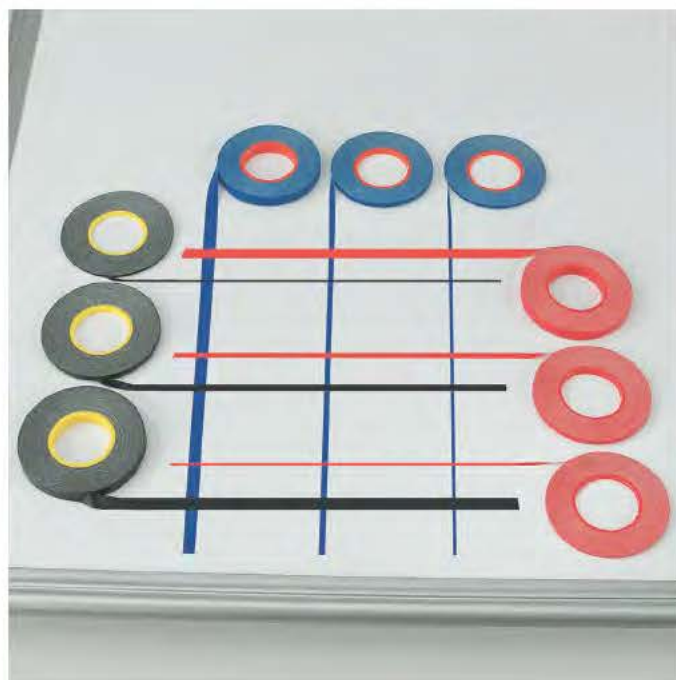

NB. Items featured on this page may incur a small order charge



Dry/Wetwipe Glass and Chalkboard Pens

Vibrant coloured pens with 9mm chisel tip.

Designed to dry-wipe from glass or wetwipe from chalkboard surfaces.

Allow to dry before attempting to erase.

Pack of 3 white pens or pack of 5 assorted colours - Red, Yellow, Pink, Green and Orange.



Wetwipe Glass Narrow Tip Pens

Coloured

For use on glass surfaces.

3mm chisel tip.

Once dry, ink can be removed with a wet cloth.

Packs of 5 assorted colours - Black, Blue, Red, Green and Yellow.



White

For use on glass surfaces.

3mm chisel tip.

Once dry, ink can be removed with a wet cloth.

Packs of 5 white pens.

White Pens
Pack of 3 **439501**
£27.81

Assorted Pens
Pack of 5 **439500**
£49.82

Assorted Pens
Pack of 5 **539100**
£15.00

White Pens
Pack of 5 **539101**
£15.00



Whiteboard Erasers

Economy Magnetic Eraser

Pack of 3 low cost lightweight erasers.

Professional Eraser

With 10 peel off faces that gives you a new cleaning surface each time.

Economy **439165**
£9.83

Professional **439164**
£8.60



Whiteboard Pen Holder

Supplied with four pens and magnetic and adhesive mounting strips.

Code **439159**
£10.41



Whiteboard Accessory Kit

Ideal for use with any laminate whiteboard.

2 self adhesive steel disks and 25mm magnets for holding paper.

Self adhesive pen holder (pen not included).

Code **439201**
£6.48



Whiteboard Spray Cleaner

Cleaning fluid for removing stubborn marks and ghosting.

Suitable for all drywipe whiteboard surfaces.

Recommended for use with DryWipes.

250ml **439163**
£8.93



Whiteboard Wet and Dry Wipes

WetWipes

Resealable tub of 50 wipes formulated with whiteboard cleaning fluid.

DryWipes

Convenient resealable tub of 100 tear off DryWipes.

50 WetWipes **439161**
£11.27

100 DryWipes **439162**
£8.60



Whiteboard Cleaning Kit

Special formula solvent free board cleaner and DryWipes supplied in a convenient holder.

Magnetic and adhesive mounting strips.

Code **439160**
£29.83



Whiteboard Starter Kit

Contains the basic items you need to get going.

Three pens in Black, Blue, Red plus an eraser; Spray Cleaner and pack of DryWipes.

Code **439177**
£30.70



Whiteboard Survival Kit

All the essentials to keep your board in pristine condition.

The kit includes WetWipes, Spray Cleaner, DryWipes, a professional eraser and 6 pens.

Pen holder is supplied with magnetic and adhesive fixings to mount on any style of board.

Code **439178**
£58.55



Glass Whiteboard and Chalkboard Cleaner

A 250ml pump action Spray Cleaner for refreshing boards periodically.

Removes stubborn stains from porous surfaces.

Handle with care - read instructions before use.

250ml bottle **539102**
£6.10

NB. Items featured on these pages may incur a small order charge



Magnetic Sheets

Colourful A4 magnetic sheets can be cut into any shape to suit your application.

Ideal for colour coding, heading strips and even planning or organisational charts.

Black, Red, Blue, Green, Yellow and White.

Durable material.

Black	439137	£8.78
Red	439138	£8.78
Blue	439139	£8.78
Green	439140	£8.78
Yellow	439141	£8.78
White	439142	£8.78



Magnetic Tape

10mm wide rolls of coloured magnetic tape.

Create temporary lines on a steel whiteboard.

Can be used for simple paper and memo hanging on a steel surface such as filing cabinets.

Black, Red, Blue, Green, Yellow or White.

Supplied in 5m rolls.

Black	439131	£5.83
Red	439132	£5.83
Blue	439133	£5.83
Green	439134	£5.83
Yellow	439135	£5.83
White	439136	£5.83



Coloured Magnets

Colourful magnets available in different sizes to suit your application.

Supplied in packs of 10 in a variety of colours.

The ergonomically designed outer disk makes the magnet easy to lift and reposition.

Diameter	20mm		30mm	
Black	439147	£5.83	439152	£6.88
Red	439148	£5.83	439153	£6.88
Blue	439149	£5.83	439154	£6.88
Green	439150	£5.83	439155	£6.88
Assorted	439151	£5.83	439156	£6.88



Magnetic Shapes

Magnetic shapes have been used for many years as a visual aid in project and production planning, training applications etc.

Each sheet has 81 die cut shapes of various sizes.

Includes arrows, squares, circles and triangles.

Pack of 6 assorted colours Black, White, Blue, Green, Red and Yellow.

Measures 150 x 150mm.

Pack of 6	439130	
	£32.96	



Magnetic Characters

Magnetic letters and numbers can be used for a multitude of uses around any work place.

Use to create simple signage, headers on white boards, and even to create your own in-out board.

Square cut letters for simple alignment.

A4 sheet with 23mm or 43mm high characters.

Height	23mm		43mm	
Letters	439143	£23.93	439145	£23.93
Numbers	439144	£23.93	439146	£23.93



Super Strength Magnets

These high power neodymium magnets have Herculean strength for their size.

Ideal for affixing heavier material.

Available in 2 sizes, 16mm and 25mm diameter.

Striking machined finish.

25mm magnets can also be used on glass whiteboards - see pages 6-9.

Sizeable ridges to assist in lifting or relocating.

Diameter	16mm		25mm	
Pack of 5	439157	£22.93		
Pack of 2			439158	£17.74

A4 Magnetic Clear Pockets

Magnetic anti-glare PET pockets are ideal for displaying A4 sized printed material.

For use on VES or coated steel whiteboards.

Available in 4 popular colours.

3 pack sizes to suit your requirements.

EACH

Red	43990R	£10.83
White	43990W	£10.83
Black	43990B	£10.83
Grey	43990G	£10.83

PACK OF 5

Red	43991R	£24.58
White	43991W	£24.58
Black	43991B	£24.58
Grey	43991G	£24.58

PACK OF 10

Red	43992R	£52.25
White	43992W	£52.25
Black	43992B	£52.25
Grey	43992G	£52.25



WriteOn® Magnetic Flip Pad Holder

Holds any pre-drilled A1 flipchart pad.

Sprung clamp neatly covers the mounting hooks.

Rear magnet adheres to any steel surface.

Size	H 55mm
	W 665mm
	D 30mm
Code	446002
	£31.14

NB. Items featured on these pages may incur a small order charge

Buzzard Mobile Flipchart Easel

Mobile easel on a five star base with locking castors.

Height adjustable with spring loaded assist.

2 Side arms for hanging completed sheets.

Adjustable hangers suitable for all A1 pre-drilled flip pads.

Full width pen tray.

Locking castors for ease of movement.



FULL WIDTH PEN TRAY



ADJUSTABLE PAD HANGERS



Board Size	1000 x 680mm
Max Height	1900mm
Weight	14kg
Code	449505
	£151.67

WriteOn® Flipchart Pads

Pack of 5 Pads

450010 **£27.89**

For other accessories please see pages 42

WriteOn® Whiteboard Pens

Wallet of 4 pens:

1 of each Black, Blue, Red, Green

439115 **£6.93**

Pack of 10 pens:

3 Black, 2 Blue, 3 Red, 2 Green

439116 **£13.77**

Self Adhesive Gridding Tape
and other accessories

See pages 33-36

WriteOn® Flipchart Easels

Flexible presentation aids.
All take A1 pre-drilled flip pads.
Height Adjustable.

Drywipe boards accept magnets.
All designed with pen trays.
Mobile and transportable models.

WriteOn® Flipchart Pads

Pack of 5 Pads

450010 £27.89

For other accessories please see page 42

WriteOn® Whiteboard Pens

Wallet of 4 pens:

1 of each Black, Blue, Red, Green

439115 £6.93

Pack of 10 pens:

3 Black, 2 Blue, 3 Red, 2 Green

439116 £13.77

Self Adhesive Gridding Tape
and other accessories

See pages 33-36

Cygnet Tripod Flipchart Easel



An affordable tripod easel with premium features.

Rear leg has a brace for increased stability.

Board Size	1000 x 680mm
Max height	1850mm
Weight	8kg
Easel	443000
	£73.38

Hawk Tripod Flipchart Easels



Tripod easel with rear leg tie bar for extra stability.

Telescopic legs that allow simple height adjustment.

Available with black or white frame.

Board Size	1000 x 680mm
Max Height	1850mm
Weight	10kg
Black	445000
	£90.37
White	445001
	£90.37

Combi mobile information board



Freestanding board with whiteboard one side, noticeboard on reverse.

Pinboard side is available in a choice of Grey or Blue

Height adjustable.

Stable powder coated steel frame, with four castors two of which are lockable.

Board Size	1200 x 700mm
Grey Felt	448050
	£134.53
Blue Felt	448052
	£134.53

Conference Pro Flipchart Easel



Height adjustable from seated to standing height.

Legs interlock with wheels.

Integral side arm for hanging completed sheets.

Light aluminium construction.

Board Size	1000 x 700mm
Max Height	1920mm
Weight	11kg
Code	463770
	£377.72

Sales last quarter

Sales target this quarter

End of year projection

European exports

New warehouse

AOB



WriteOn® Flipchart Pads

Pack of 5 Pads

450010 £27.89

For other accessories please see page 42

WriteOn® Whiteboard Pens

Wallet of 4 pens:

1 of each Black, Blue, Red, Green

439115 £6.93

Pack of 10 pens:

3 Black, 2 Blue, 3 Red, 2 Green

439116 £13.77**Self Adhesive Gridding Tape
and other accessories**

See pages 33-36



Ultimate Loop Leg Easel

Loop leg design with foot bar to aid stability when writing.

Double sided whiteboard is fully height adjustable and can be angled to aid presentation.

Optional carry bag.

Board Size	860 x 650mm
Max Height	1720mm
Weight	7.15kg
Blue	448084
Red	448082
Green	448085
Black	448081
Grey	443001
White	448086
	£115.71
Carry bag	448083
	£33.08



BLUE RED GREEN BLACK GREY WHITE

Ultimate Mobile Easel



The mobile version of our bestselling Ultimate easel.
Large magnetic whiteboard.
Height adjustable column with locking castors.

Board Size	1000 x 680mm
Max Height	1900mm
Weight	15kg
Blue	449603
Red	449602
Green	449604
Black	449601
Grey	449605
White	449606
	£179.12



BLUE RED GREEN BLACK GREY WHITE





WriteOn® Flipchart Pads

Ideal for easels and mobile whiteboards

40 sheet pad with perforated top, supplied in a pack of 5

70gsm recycled bleedproof paper for use with flipchart pens

5 pack	450010	£27.89
5 packs of 5	450010/5	£118.33
10 packs of 5	450010/10	£216.67
20 packs of 5	450010/20	£413.33



WriteOn® Drywipe Pen with NEW Ink Formula

New ink formula is now glassboard compatible.

These pens are ideal for all standard whiteboards and now, due to a new ink formula, can also be used on glassboards.

Quick drying, low odour and non-toxic. 6mm bullet tip.

Also non-bleed on flip pad paper.

Storage advice - store vertically, lid down.



WALLET OF 4 PENS

1 of each Black, Blue,
Red, Green

Code **439115**
£6.93

BOX OF 10 PENS

3 x Black, 3 x Red,
2 x Blue, 2 x Green

Code **439116**
£13.77



NB. Items featured on this page may incur a small order charge

TRAPEASE



Trapease® Paper Hanging System

Ingenious rail for hanging paper or card.

Trapease is so simple to use, simply insert a sheet of paper and it is held in place with specially designed rollers.

Lift the sheet of paper and it is released.

Ideal for training rooms, brainstorming sessions, hanging artwork, maps and charts.

Various thicknesses of material can be held side by side.

Available in three standard lengths, and can be butted end to end to create longer runs.

Easy snap fit or adhesive strip mounting.



600mm		1200mm		1800mm	
Size	H 54mm W 600mm D 22mm	Size	H 54mm W 1200mm D 22mm	Size	H 54mm W 1800mm D 22mm
Code	TE060 £29.39	Code	TE120 £40.86	Code	TE180 £52.82

PUSH UP TO LOCATE AND HANG



PUSH UP



.... AND OVER TO RELEASE - SIMPLE!





BusyRail® Deluxe

Premium quality rail system is packed with user friendly features and is consistently specified for aesthetic appeal and long term durability. Equipment locates securely on the rail, yet glides effortlessly when required. Whiteboard and noticeboard products have the additional benefit of small guide wheels attached at the lower edge for even greater mobility. Components are adaptable for use with both MonoGlide and DualGlide rail. The recommended installation height for rail is approx. 2000 - 2100mm from the floor (or in line with the top of the door frame). Rails are manufactured from strong coated aluminium extrusion. Ingenious integral paper hanging facility - ideal for brainstorming. Supplied in 2400mm lengths complete with all fixings and end caps. Optional moulded corner pieces which are radiused so that equipment can easily be moved round and across inside corners.

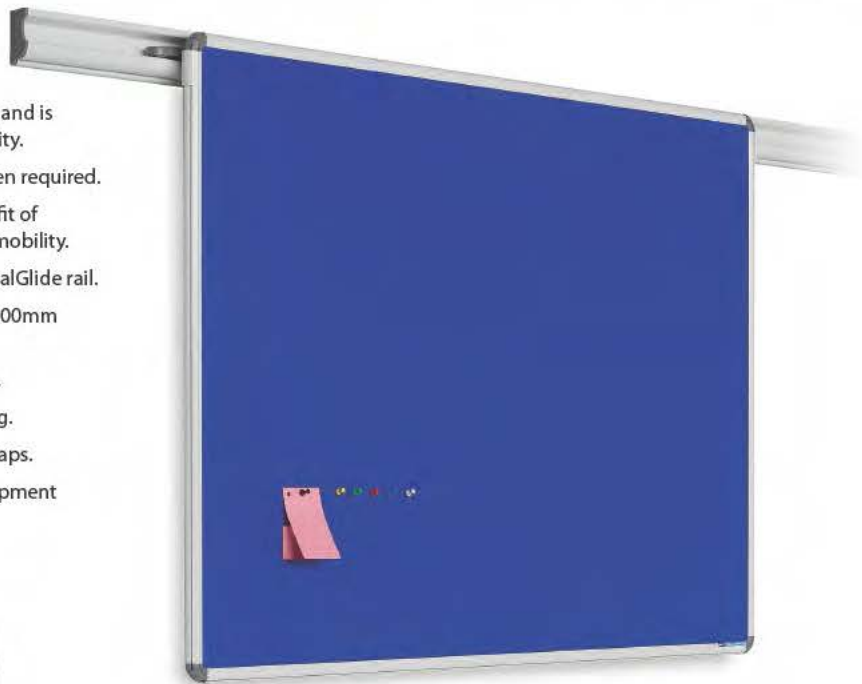

MonoGlide 2.4m Rail

A single rail - suitable for simple installations. Items cannot pass on this rail.

MonoGlide			
Size	L	2400mm	
Rail	BR1000	£108.01	
Corner Piece	BR1001	£21.58	



DualGlide 2.4m Rail

Items such as screens and flipcharts can be moved effortlessly over the top of whiteboards and noticeboards without removing them from the wall.

DualGlide			
Size	L	2400mm	
Rail	BR1020	£143.72	
Corner Piece	BR1021	£34.69	

Felt Noticeboards

3 noticeboard sizes in 3 felt colours. Felt covered boards accept loop nylon fasteners as well as pins.



Size	H	600mm	
	W	900mm	
Blue	BR1009/BL	£153.81	
Grey	BR1009/GY	£153.81	
Burgundy	BR1009/BU	£153.81	
Size	H	900mm	
	W	1200mm	
Blue	BR1010/BL	£227.56	
Grey	BR1010/GY	£227.56	
Burgundy	BR1010/BU	£227.56	
Size	H	900mm	
	W	1800mm	
Blue	BR1011/BL	£328.91	
Grey	BR1011/GY	£328.91	
Burgundy	BR1011/BU	£328.91	



Magnetic Whiteboards

Top quality steel whiteboard surface.
Accepts magnets as well as drywipe markers.
Supplied complete with a useful pen tray.

Projection Screens

Integral struts are incorporated into the design to allow adjustment of the screen angle.
Supplied ready assembled.
Perfectly flat rigid board surface.

Whiteboard

Size H 600mm
W 900mm

Code **BR1006**
£134.00

Whiteboard

Size H 900mm
W 1200mm

Code **BR1007**
£195.76

Whiteboard

Size H 900mm
W 1800mm

Code **BR1008**
£319.36

Screen

Size H 1250mm
W 1250mm

Code **BR1014**
£733.95

Screen

Size H 1500mm
W 1500mm

Code **BR1015**
£773.78

Screen

Size H 1800mm
W 1800mm

Code **BR1022**
£1173.08



Flipchart Easel

Fully adjustable quick release pad clamp.
Accepts any pre-drilled 2 hole A1 flip pad.
Whiteboard surface that accepts magnets as well as dry-wipe markers.
Incorporates a useful pen tray.

Code **BR1002**
£331.93

Shelving Units

Sturdy shelving 500mm or 300mm deep.
Both shelving units have 2 shelves, upper shelf being height adjustable.
White frame with grey shelves.
Max. combined weight for both shelves - 25kg.

Shelf Size W 790mm

D 500mm
TV Shelf **BR1016**
£534.59

Shelf Size W 790mm

D 300mm
Book Shelf **BR1017**
£482.75

Leaflet Dispenser and Hooks

Leaflet Dispenser

10 clear A4 acrylic pockets mounted on a backing board.

10 Pocket **BR1018**
£329.28

Picture Hooks

For hanging pictures, coats or flipchart sheets.

Pack of 4 **BR1019**
£19.19



Unframed Noticeboards

Can be mounted portrait or landscape.
Mounts through the board.
Capped fixings are supplied.
3 larger sizes are supplied in 2 parts.



Standard felt

Pinnable and Velcro® friendly noticeboard covered with traditional felt cloth.
Available in a choice of 5 colours.



ColourPlus loop nylon

Bright contemporary cloth colour finishes
ColourPlus offers a selection of 6 bright fabric colours.
Designed for use with Velcro® and pins.





Size H 600mm
W 900mm
Standard Felt **UNB32/**** £30.05
ColourPlus® **UCP9060/**** £31.08



Size H 900mm
W 1200mm
Standard Felt **UNB43/**** £47.40
ColourPlus® **UCP1290/**** £41.42



Size H 1200mm
W 1200mm
Standard Felt **UNB44/**** £55.26
ColourPlus® **UCP1212/**** £57.42



Supplied in 2 parts for ease of installation

Size H 1200mm
W 1500mm
Standard Felt **UNB54/**** £69.73
ColourPlus® **UCP1512/**** £71.58



Supplied in 2 parts for ease of installation

Size H 1200mm
W 1800mm
Standard Felt **UNB64/**** £76.12
ColourPlus® **UCP1812/**** £88.92

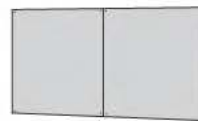

Supplied in 2 parts for ease of installation

Size H 1200mm
W 2400mm
Standard Felt **UNB84/**** £94.72
ColourPlus® **UCP2412/**** £89.42

** Please add code of colour required

** Please add code of colour required

** Please add code of colour required



Resist-a-Flame® Unframed Noticeboards

Fire retardant noticeboards - fully tested to European Reaction to Fire Test - see yellow panel for more details.

Suitable for mounting in corridors.

Can be mounted portrait or landscape.

Mounts through the board.

Capped fixings are supplied.

3 larger sizes are supplied in 2 parts.



Eco-Colour®

Made from recycled waste material.

Acoustic properties to help reduce noise, up to NRC 0.8.

Available in a choice of 11 colours.



Woven cloth

Original Resist-a-Flame® with durable woven cloth covered board.

Available in a choice of 9 colours.





European reaction to fire test

Resist-Flame®
FIRE RESISTANT NOTICEBOARDS

Resist-a-Flame® noticeboard construction has been tested and classified to European 'Reaction to Fire' test standard and is suitable for use within sensitive public areas such as corridors, stairways and entrances.

The cloth and pinboard core assembly is classified as B according to BS EN 13501-1.

This identifies that these products can be used in the same areas as products tested to BS476 Parts 6 & 7 and classified as 0.



Size H 600mm
W 900mm
Eco-Colour® **UFB32/**** £29.93
Woven Cloth **URF32/**** £62.46



Size H 900mm
W 1200mm
Eco-Colour® **UFB43/**** £48.75
Woven Cloth **URF43/**** £97.25



Size H 1200mm
W 1200mm
Eco-Colour® **UFB44/**** £63.92
Woven Cloth **URF44/**** £117.04



Woven Supplied in 2 parts for ease of installation

Size H 1200mm
W 1500mm
Eco-Colour® **UFB54/**** £81.58
Woven Cloth **URF54/**** £144.75



Woven Supplied in 2 parts for ease of installation

Size H 1200mm
W 1800mm
Eco-Colour® **UFB64/**** £94.42
Woven Cloth **URF64/**** £159.54



Woven Supplied in 2 parts for ease of installation

Size H 1200mm
W 2400mm
Eco-Colour® **UFB84/**** £123.17
Woven Cloth **URF84/**** £197.46

** Please add code of colour required

** Please add code of colour required

** Please add code of colour required

Aluminium Framed Noticeboards

Anodised aluminium frame with nylon round corners.

Concealed corner fixings, supplied.

Accepts Velcro® and pins.

Can be mounted portrait or landscape.

12 colour options.

Standard felt option available in 7 sizes.



Standard felt or cork

Pinnable and Velcro® friendly noticeboard covered with traditional felt cloth.

Available in a choice of 5 colours.







ColourPlus loop nylon

Bright contemporary cloth colour finishes.

ColourPlus offers a selection of 6 bright fabric colours.

Designed for use with Velcro® and pins.



			
Size H 450mm W 600mm	Size H 600mm W 900mm	Size H 900mm W 1200mm	Size H 1200mm W 1200mm
Felt or Cork 44531/**	Felt or Cork 44532/**	Felt or Cork 44543/**	Felt or Cork 44544/**
£25.15	£32.46	£48.46	£57.07
	ColourPlus® PS9060/**	ColourPlus® PS1290/**	ColourPlus® PS1212/**
	£34.49	£58.70	£60.98
			
Size H 1200mm W 1500mm	Size H 1200mm W 1800mm	Size H 1200mm W 2400mm	
Felt or Cork 44554/**	Felt or Cork 44564/**	Felt or Cork 44584/**	
£67.57	£77.40	£93.65	
ColourPlus® PS1512/**	ColourPlus® PS1812/**	ColourPlus® PS2412/**	
£78.97	£89.32	£118.09	

** Please add code of colour required

** Please add code of colour required

** Please add code of colour required



Resist-a-Flame® Aluminium Framed Noticeboards

- Fully tested to European Reaction to Fire Test - see yellow panel for more details.
- Suitable for mounting in corridors.
- Anodised aluminium frame with nylon round corners.
- Concealed corner fixings, supplied.
- Can be mounted portrait or landscape.
- 20 colour options.
- For use with pins.



Eco-Colour®

- Made from recycled waste material.
- Acoustic properties to help reduce noise, up to NRC 0.8.
- Available in a choice of 11 colours.



Woven cloth

- Original Resist-a-Flame® with durable woven cloth covered board.
- Available in a choice of 9 colours.





European reaction to fire test

Resist Flame[®]
FIRE RESISTANT NOTICEBOARDS

Resist-a-Flame[®] noticeboard construction has been tested and classified to European 'Reaction to Fire' test standard and is suitable for use within sensitive public areas such as corridors, stairways and entrances.

The cloth and pinboard core assembly is classified as B according to BS EN 13501-1.

This identifies that these products can be used in the same areas as products tested to BS476 Parts 6 & 7 and classified as 0.



Size H 600mm
W 900mm
Eco-Colour[®] **22632/****
Woven Cloth **45381/****

£44.26
£71.83



Size H 900mm
W 1200mm
Eco-Colour[®] **22643/****
Woven Cloth **45391/****

£78.38
£111.21



Size H 1200mm
W 1200mm
Eco-Colour[®] **22644/****
Woven Cloth **45401/****

£91.84
£132.67



Size H 1200mm
W 1500mm
Eco-Colour[®] **22654/****
Woven Cloth **45441/****

£114.58
£166.04



Size H 1200mm
W 1800mm
Eco-Colour[®] **22664/****
Woven Cloth **45411/****

£131.84
£193.75



Size H 1200mm
W 2400mm
Eco-Colour[®] **22684/****
Woven Cloth **45421/****

£166.86
£238.33

** Please add code of colour required

** Please add code of colour required

** Please add code of colour required

EF Eco-Friendly® Noticeboards

LIGHT OAK EFFECT



ALUMINIUM EFFECT



MAHOGANY EFFECT



Environmentally friendly felt or cork pinnable noticeboards in 3 frame finishes.

Constructed from recycled and sustainable materials.

Contoured 35mm wide frame.

Available in a choice of Light Oak, Mahogany or Aluminium effect finishes.

Choice of 5 felt colours or traditional Cork.

6 new ColourPlus loop nylon colours are available with the Light Oak effect frame.

Boards can be mounted portrait or landscape with concealed fixings provided.

Standard felt or Cork

Pinnable and Velcro® friendly noticeboard covered with traditional felt cloth.

Available in a choice of 5 colours.



ColourPlus loop nylon

Bright contemporary cloth colour finishes.

ColourPlus offers a selection of 6 bright fabric colours with Light Oak frame.

Designed for use with Velcro® and pins.



Size H 600mm
W 900mm

Felt or Cork

Light Oak Effect	EF9060/**	£37.97
Aluminium Effect	EFA9060/**	£37.97
Mahogany Effect	EFM9060/**	£37.97
ColourPlus		
Light Oak Effect	EF9060/**	£43.53



Size H 900mm
W 1200mm

Felt or Cork

Light Oak Effect	EF1290/**	£52.42
Aluminium Effect	EFA1290/**	£52.42
Mahogany Effect	EFM1290/**	£52.42
ColourPlus		
Light Oak Effect	EF1290/**	£61.75



Size H 1200mm
W 1200mm

Felt or Cork

Light Oak Effect	EF1212/**	£60.64
Aluminium Effect	EFA1212/**	£60.64
Mahogany Effect	EFM1212/**	£60.64
ColourPlus		
Light Oak Effect	EF1212/**	£70.86



Size H 1200mm
W 1500mm

Felt or Cork

Light Oak Effect	EF1512/**	£82.31
Aluminium Effect	EFA1512/**	£82.31
Mahogany Effect	EFM1512/**	£82.31
ColourPlus		
Light Oak Effect	EF1512/**	£94.97



Size H 1200mm
W 1800mm

Felt or Cork

Light Oak Effect	EF1812/**	£96.67
Aluminium Effect	EFA1812/**	£96.67
Mahogany Effect	EFM1812/**	£96.67
ColourPlus		
Light Oak Effect	EF1812/**	£111.56



Size H 1200mm
W 2400mm

Felt or Cork

Light Oak Effect	EF2412/**	£118.22
Aluminium Effect	EFA2412/**	£118.22
Mahogany Effect	EFM2412/**	£118.22
ColourPlus		
Light Oak Effect	EF2412/**	£137.78

** Please add code of colour required

** Please add code of colour required

** Please add code of colour required



EF Eco-Friendly® Noticeboards

Environmentally friendly pinnable noticeboards.

Constructed from recycled and sustainable materials.

Contoured 35mm wide frame.

Available in a choice of Light Oak effect frames with 11 colour infills or 4 coloured frame/infill combinations.

Boards can be mounted portrait or landscape with concealed fixings provided.

Acoustic properties to help reduce noise, up to NRC 0.8.



EF Eco-Colour® Light Oak

Eco-friendly noticeboards with light oak effect frames to combine with a choice of 11 colour infills.

EF Contrast

Eco-friendly noticeboards with 4 attractive contrasting colour schemes.

Aluminium framed contrast boards can be created - see Shield® range on pages 60-61.



Size H 600mm
W 900mm

EF Light Oak **EFC32/**** **£44.84**
EF Contrast **ECB32/**** **£47.47**



Size H 900mm
W 1200mm

EF Light Oak **EFC43/**** **£63.61**
EF Contrast **ECB43/**** **£68.87**



Size H 1200mm
W 1800mm

EF Light Oak **EFC64/**** **£110.37**
EF Contrast **ECB64/**** **£114.58**



Size H 1200mm
W 2400mm

EF Light Oak **EFC84/**** **£143.68**
EF Contrast **ECB84/**** **£147.19**

** Please add code of colour required

** Please add code of colour required

** Please add code of colour required

** Please add code of colour required



EF LIGHT OAK



EF CONTRAST

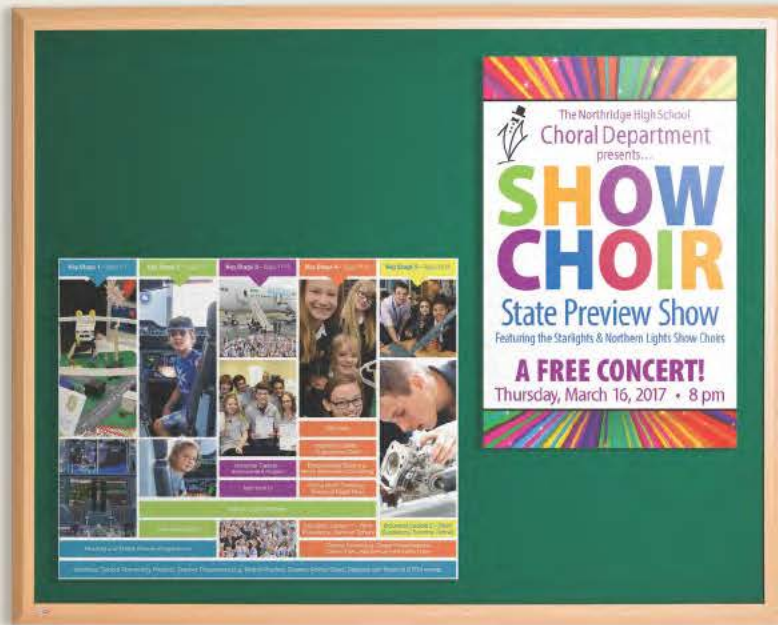

EF Eco-Friendly® Premier Noticeboards



Modern bevelled design with a rich grained Beech effect or Black finish.
 5 felt cloth colours or traditional Cork.
 The angled 46mm wide frame tapers away towards the wall, cleverly making the board appear slimmer than it is.
 Frame and pinboard core are constructed from timber industry bi-products and recycled materials.
 All boards can be mounted portrait or landscape with fixings provided.

BEECH EFFECT

BLACK FRAME



Size H 600mm
 W 900mm
 Beech Effect **PBF32/**** £48.27
 Black Frame **PBL32/**** £48.27



Size H 900mm
 W 1200mm
 Beech Effect **PBF43/**** £62.53
 Black Frame **PBL43/**** £62.53



Size H 1200mm
 W 1200mm
 Beech Effect **PBF44/**** £70.31
 Black Frame **PBL44/**** £70.31



Size H 1200mm
 W 1500mm
 Beech Effect **PBF54/**** £97.04
 Black Frame **PBL54/**** £97.04



Size H 1200mm
 W 1800mm
 Beech Effect **PBF64/**** £102.04
 Black Frame **PBL64/**** £102.04



Size H 1200mm
 W 2400mm
 Beech Effect **PBF84/**** £119.63
 Black Frame **PBL84/**** £119.63



** Please add code of colour required

** Please add code of colour required

** Please add code of colour required



Size	H 450mm		
	W 600mm		
Aluminium	45531/AL/**	£41.50	
Blue	45531/BL/**	£59.58	
Red	45531/RD/**	£59.58	
Green	45531/GR/**	£59.58	
White	45531/WH/**	£59.58	
Black	45531/BK/**	£59.58	

** Please add code of colour required



Size	H 600mm		
	W 900mm		
Aluminium	45532/AL/**	£53.79	
Blue	45532/BL/**	£71.75	
Red	45532/RD/**	£71.75	
Green	45532/GR/**	£71.75	
White	45532/WH/**	£71.75	
Black	45532/BK/**	£71.75	

Wood **45532/LO/**** **£53.26**
 ** Please add code of colour required



Size	H 900mm		
	W 1200mm		
Aluminium	45543/AL/**	£80.45	
Blue	45543/BL/**	£99.42	
Red	45543/RD/**	£99.42	
Green	45543/GR/**	£99.42	
White	45543/WH/**	£99.42	
Black	45543/BK/**	£99.42	

Wood **45543/LO/**** **£76.77**
 ** Please add code of colour required



Shield® Design Noticeboards

Aluminium framed noticeboards with a distinctive contemporary styling.

This premier range of noticeboards has a raised frame.

Available in satin aluminium, 5 attractive frame colours or new Light Oak effect frames.

7 sizes are available in 18 loop nylon cloth colours or traditional Cork.

Can be mounted portrait or landscape with concealed corner fixings.

Part of the Shield® co-ordinated range of display products.



SATIN ALUMINIUM



COLOURED FRAME



WOOD EFFECT FRAME



FRAME COLOURS

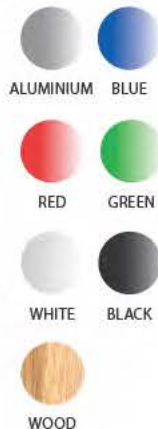

LOOP NYLON CLOTH COLOURS



Size	H 1200mm		
	W 1200mm		
Aluminium	45544/AL/**	£92.65	
Blue	45544/BL/**	£115.75	
Red	45544/RD/**	£115.75	
Green	45544/GR/**	£115.75	
White	45544/WH/**	£115.75	
Black	45544/BK/**	£115.75	
Wood	45544/LO/**	£78.52	

** Please add code of colour required



Size	H 1200mm		
	W 1500mm		
Aluminium	45554/AL/**	£109.85	
Blue	45554/BL/**	£136.08	
Red	45554/RD/**	£136.08	
Green	45554/GR/**	£136.08	
White	45554/WH/**	£136.08	
Black	45554/BK/**	£136.08	
Wood	45554/LO/**	£111.43	

** Please add code of colour required



Size	H 1200mm		
	W 1800mm		
Aluminium	45564/AL/**	£131.93	
Blue	45564/BL/**	£152.33	
Red	45564/RD/**	£152.33	
Green	45564/GR/**	£152.33	
White	45564/WH/**	£152.33	
Black	45564/BK/**	£152.33	
Wood	45564/LO/**	£127.37	

** Please add code of colour required



Size	H 1200mm		
	W 2400mm		
Aluminium	45584/AL/**	£154.74	
Blue	45584/BL/**	£169.33	
Red	45584/RD/**	£169.33	
Green	45584/GR/**	£169.33	
White	45584/WH/**	£169.33	
Black	45584/BK/**	£169.33	
Wood	45584/LO/**	£146.84	

** Please add code of colour required



Shield Resist-a-Flame® Noticeboards

Aluminium framed noticeboards with a distinctive contemporary styling.

Available in satin Aluminium, 5 attractive frame colours or new Light Oak effect frames.

A large range of 20 board colours.

Can be mounted portrait or landscape.

Concealed corner fixings.

Core complies with EN13501-1 Class B for Fire Retardancy - see page 49.

Suitable for mounting in corridors.

Multi-Bank Eco-Colour®

Noticeboard with separated pinnable areas that can be specified with individual colours.

Combine Aluminium or White frame with one of the 11 Eco-Colour® options.

For multi-coloured units, just add the colour codes in sequence - ie **SMB92/AL/PU/OR/AG/RS** for Multi-Bank unit featured.



FRAME COLOURS



ALUMINIUM BLUE RED GREEN WHITE BLACK WOOD

Resist-a-Flame®
FIRE RESISTANT NOTICEBOARDS



SATIN ALUMINIUM

COLOURED FRAMES TO COMPLEMENT OR CONTRAST WITH ECO-COLOUR® BOARDS

WOOD EFFECT



Eco-Colour®

Acoustic properties to help reduce noise, up to NRC 0.8.

Pinnable noticeboards - no cloth covering.

					
Size H 600mm W 900mm	Size H 900mm W 1200mm	Size H 1200mm W 1200mm	Size H 1200mm W 1500mm	Size H 1200mm W 1800mm	Size H 1200mm W 2400mm
Aluminium 30132/AL/** £58.70	Aluminium 30143/AL/** £86.77	Aluminium 30144/AL/** £104.76	Aluminium 30154/AL/** £123.18	Aluminium 30164/AL/** £142.30	Aluminium 30184/AL/** £178.77
Blue 30132/BL/**	Blue 30143/BL/**	Blue 30144/BL/**	Blue 30154/BL/**	Blue 30164/BL/**	Blue 30184/BL/**
Red 30132/RD/**	Red 30143/RD/**	Red 30144/RD/**	Red 30154/RD/**	Red 30164/RD/**	Red 30184/RD/**
Green 30132/GR/**	Green 30143/GR/**	Green 30144/GR/**	Green 30154/GR/**	Green 30164/GR/**	Green 30184/GR/**
White 30132/WH/**	White 30143/WH/**	White 30144/WH/**	White 30154/WH/**	White 30164/WH/**	White 30184/WH/**
Black 30132/BK/** £81.50	Black 30143/BK/** £113.43	Black 30144/BK/** £133.53	Black 30154/BK/** £155.99	Black 30164/BK/** £175.11	Black 30184/BK/** £215.09
Wood 30132/LO/** £63.79	Wood 30143/LO/** £91.33	Wood 30144/LO/** £108.27	Wood 30154/LO/** £137.04	Wood 30164/LO/** £150.90	Wood 30184/LO/** £186.84

** Please add code of colour required

				
Size H 900mm W 1200mm	Size H 900mm W 1800mm	Size H 900mm W 2400mm	Size H 1200mm W 1800mm	Size H 1200mm W 2700mm
No. of Panels 2	No. of Panels 3	No. of Panels 4	No. of Panels 2	No. of Panels 3
Aluminium SMB92/AL/** £125.63	Aluminium SMB93/AL/** £198.24	Aluminium SMB94/AL/** £254.12	Aluminium SMB122/AL/** £173.14	Aluminium SMB123/AL/** £244.51
White SMB92/WH/** £155.44	White SMB93/WH/** £232.75	White SMB94/WH/** £292.35	White SMB122/WH/** £209.80	White SMB123/WH/** £287.25

** Please add code of colour required - To order multi-coloured units see opposite page



Woven Cloth Covered

Traditional pinnable noticeboards with cloth covering.

					
Size H 600mm W 900mm	Size H 900mm W 1200mm	Size H 1200mm W 1200mm	Size H 1200mm W 1500mm	Size H 1200mm W 1800mm	Size H 1200mm W 2400mm
Aluminium R5532/AL/** £78.29	Aluminium R5543/AL/** £125.38	Aluminium R5544/AL/** £153.75	Aluminium R5554/AL/** £188.96	Aluminium R5564/AL/** £215.00	Aluminium R5584/AL/** £263.54
Blue R5532/BL/**	Blue R5543/BL/**	Blue R5544/BL/**	Blue R5554/BL/**	Blue R5564/BL/**	Blue R5584/BL/**
Red R5532/RD/**	Red R5543/RD/**	Red R5544/RD/**	Red R5554/RD/**	Red R5564/RD/**	Red R5584/RD/**
Green R5532/GR/**	Green R5543/GR/**	Green R5544/GR/**	Green R5554/GR/**	Green R5564/GR/**	Green R5584/GR/**
White R5532/WH/**	White R5543/WH/**	White R5544/WH/**	White R5554/WH/**	White R5564/WH/**	White R5584/WH/**
Black R5532/BK/** £99.55	Black R5543/BK/** £148.18	Black R5544/BK/** £177.33	Black R5554/BK/** £211.05	Black R5564/BK/** £240.20	Black R5584/BK/** £289.80

** Please add code of colour required



Dual Felt/Drywipe Noticeboards

Combination pinnable notice and drywipe board.

Half whiteboard, complimented by a choice of 5 felt colours or traditional cork for the pinnable noticeboard surface.



Aluminium Framed

20mm wide Aluminium frame with satin finish.

Concealed corner fixings.

Comes with push-on pen tray.



Size H 600mm
W 900mm

Aluminium **D4554/**** **£37.04**
Light Oak **ED9060/**** **£51.86**

** Please add code of colour required



Size H 900mm
W 1200mm

Aluminium **D4555/**** **£59.41**
Light Oak **ED1290/**** **£69.93**

** Please add code of colour required



Size H 1200mm
W 1800mm

Aluminium **D4556/**** **£106.15**
Light Oak **ED1812/**** **£122.11**

** Please add code of colour required

EF Light Oak Framed

35mm wide Eco frame with a Light Oak finish.

Concealed hook-on fixings.

Made from timber industry bi-product.





buy 2 tickets
for the
Design Show





DOUBLE DOOR FELT



THEMEBOARD



Tamperproof Noticeboards



DOUBLE DOOR COLOURPLUS®

Our most popular covered noticeboards with lockable doors.

An effective way of protecting notices from casual interference in busy public areas.

7 popular sizes available with a choice of Felt or ColourPlus loop nylon colour options.

Locks with matching keys per door.

Single door versions can be mounted portrait or landscape with hinge to side, base or top.

Do not include support stays.

Themeboard

Add your Club name, House or Department to these lockable covered noticeboards

Lockable noticeboards with a 200mm deep drywipe surface header.

State the Theme to be displayed by either drywipe pen or applying lettering or graphics.

Choose from 6 colours of felt board for use with pins or Velcro®

Standard felt

Pinnable and Velcro® friendly noticeboard covered in a choice of 6 felt colours.

For use with Standard or Themeboard Tamperproofs



ColourPlus loop nylon

ColourPlus offers a selection of 6 bright loop nylon colours.

Designed for use with Velcro® and pins.

For use with Standard Tamperproofs



Size H 600mm
W 450mm
Felt **TP6045/**** **£76.44**



Size H 900mm
W 600mm
Felt **TP9060/**** **£79.25**
ColourPlus® **PST9060/**** **£99.55**
Themeboard **TPH9060/**** **£138.64**



Size H 900mm
W 900mm
Felt **TP9090/**** **£101.10**
ColourPlus® **PST9090/**** **£120.53**



Size H 1200mm
W 900mm
Felt **TP1290/**** **£117.58**
ColourPlus® **PST1290/**** **£142.69**
Themeboard **TPH1290/**** **£170.45**

** Please add code of colour required



Size H 1200mm
W 1200mm
Felt **TP1212/**** **£149.25**
ColourPlus® **PST1212/**** **£166.35**
Themeboard **TPH1212/**** **£194.14**

** Please add code of colour required



Size H 1200mm
W 1800mm
Felt **TP1812/**** **£227.00**
ColourPlus® **PST1812/**** **£254.71**
Themeboard **TPH1812/**** **£283.51**

** Please add code of colour required

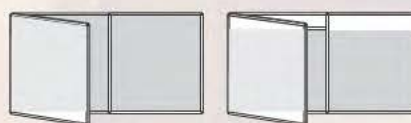

Size H 1200mm
W 2400mm
Felt **TP2412/**** **£276.83**
ColourPlus® **PST2412/**** **£299.80**
Themeboard **TPH2412/**** **£331.75**

** Please add code of colour required

Resist-a-Flame® Tamperproof Noticeboards

Fire resistant covered noticeboards with side hinged lockable doors.

Fully constructed and tested to meet the latest building and fire regulations.

Ideal for use in public buildings and industrial applications.

Available in a choice of 9 woven cloth or 11 Eco-Colour® board colours.

All tested to the latest Reaction to Fire tests - see panel.

Single door versions can be mounted portrait or landscape with hinge to side, base or top.

Top hinged Resist-a-Flame® tamperproofs - see page 69.



WOVEN CLOTH COLOURS Stocked range



WOVEN CLOTH COLOURS Extended range - made to order Please allow for a slightly longer delivery time



ECO-COLOUR BOARD COLOURS



Size H 900mm
W 600mm
Woven Cloth **45301/**** **£133.82**
Eco-Colour® **CBT32/**** **£107.08**



Size H 900mm
W 900mm
Woven Cloth **45311/**** **£174.19**



Size H 1200mm
W 900mm
Woven Cloth **45321/**** **£190.68**
Eco-Colour® **CBT43/**** **£150.75**



Size H 1200mm
W 1200mm
Woven Cloth **45331/**** **£223.27**
Eco-Colour® **CBT44/**** **£180.92**



Size H 1200mm
W 1800mm
Woven Cloth **45341/**** **£337.59**
Eco-Colour® **CBT64/**** **£263.58**



Size H 1200mm
W 2400mm
Woven Cloth **45351/**** **£406.30**
Eco-Colour® **CBT84/**** **£320.67**

** Please add code of colour required

** Please add code of colour required

** Please add code of colour required



SINGLE DOOR WOVEN CLOTH





European reaction to fire test

Resist-a-Flame[®]
FIRE RESISTANT NOTICEBOARDS

Resist-a-Flame[®] noticeboard construction has been tested and classified to European 'Reaction to Fire' test standard and is suitable for use within sensitive public areas such as corridors, stairways and entrances.

The cloth and pinboard core assembly is classified as B according to BS EN 13501-1.

This identifies that these products can be used in the same areas as products tested to BS476 Parts 6 & 7 and classified as 0.

Lockable models have clear covers tested separately to BS476 Part 7 and classified as Class 1. Made in UK.

SINGLE DOOR ECO-COLOUR[®]



DOUBLE DOOR ECO-COLOUR[®]



DOUBLE DOOR WOVEN CLOTH



Aluminium Framed Noticeboards with Fire Retardant Cloth

These aluminium framed noticeboards use the same attractive display stitchbond fabric as our Resist-a-Flame® range but with a standard fibreboard core.

The fabric is individually tested to BS5867 Part 2 2008; Type B curtains, drapes and blinds.

These boards are for use in non-sensitive areas.

For all other areas i.e. fire escapes, stairwells, lobbies etc. see **Resist-a-Flame®** products.



WOVEN CLOTH COLOURS



Open Noticeboards

Can be mounted portrait or landscape.

Mounts through concealed corner fixings.

Code	Size		
	H	W	
66532/**	900	600mm	£46.87
66543/**	1200	900mm	£65.44
66544/**	1200	1200mm	£74.82
66554/**	1200	1500mm	£91.63
66564/**	1200	1800mm	£102.74
66584/**	1200	2400mm	£122.19

** Please add code of colour required



Tamperproof Noticeboards

2 locks per door with matching keys.

Single door versions can be mounted portrait or landscape.

Code	Size		
	H	W	
Single Door			
TF9060/**	900	600mm	£112.21
TF9090/**	900	900mm	£139.61
TF1290/**	1200	900mm	£152.73
TF1212/**	1200	1200mm	£182.48

Double Door			
TF1812/**	1200	1800mm	£267.19
TF2412/**	1200	2400mm	£314.04

** Please add code of colour required





Resist-a-Flame[®]
FIRE RESISTANT NOTICEBOARDS

Resist-a-Flame[®] Corridor Tamperproof Noticeboards



The ultimate choice for use in corridor applications.

The door opens upwards and is kept in place with support stays, offering increased safety whilst changing notices.

Made in the UK to the highest specification and meet guidelines set in the BB100 document for safeguarding against fire in schools.

2 locks per door with matching keys.

Available in a choice of 9 woven cloth or 11 Eco-Colour[®] board colours.

All tested to the latest Reaction to Fire tests - see page 67.

WOVEN CLOTH COLOURS



DK BLUE CRIMSON CONIFER SILVER PLUM LT BLUE EBONY CHARCOAL CASPIAN

ECO-COLOUR[®] BOARD COLOURS



BLUE LT BLUE CHARCOAL GREY NATURAL PURPLE RASPBERRY RED ORANGE APPLE GREEN



Size	H 600mm		
	W 900mm		
Woven Cloth	47301/**	£148.82	
Eco-Colour [®]	27301/**	£136.92	



Size	H 900mm		
	W 900mm		
Woven Cloth	47302/**	£192.71	
Eco-Colour [®]	27302/**	£155.25	



Size	H 900mm		
	W 1200mm		
Woven Cloth	47303/**	£206.79	
Eco-Colour [®]	27303/**	£167.58	



Size	H 1200mm		
	W 900mm		
Woven Cloth	47305/**	£206.60	
Eco-Colour [®]	27305/**	£167.58	



Size	H 1200mm		
	W 1200mm		
Woven Cloth	47304/**	£240.49	
Eco-Colour [®]	27304/**	£196.42	



Size*	H 900mm		
	W 1800mm		
Woven Cloth	4536/**	£392.59	
Eco-Colour [®]	2736/**	£308.92	



Size*	H 1200mm		
	W 1800mm		
Woven Cloth	4538/**	£420.37	
Eco-Colour [®]	2738/**	£333.58	



Size*	H 1200mm		
	W 2400mm		
Woven Cloth	4537/**	£488.15	
Eco-Colour [®]	2737/**	£390.33	

** Please add code of colour required

** Please add code of colour required

** Please add code of colour required

** Please add code of colour required

* Double door top hinged units are delivered in two parts for ease of installation.

Shield® Design Tamperproof Noticeboards

Contemporary framed premium lockable noticeboards.

Contemporary styling, with a wide range of frame and cloth colours for this deluxe covered noticeboard.

Available in Satin Aluminium, 5 attractive frame colours or new Light Oak effect frames.

Heavy duty design and construction using quality hinges, locks, 3mm thick PET covers and full length glazing bars.

Single door versions can be mounted portrait or landscape with hinge to side, base or top.



ALUMINIUM FRAME



COLOURED FRAME



WOOD EFFECT FRAME



Size	H 900mm W 600mm		
Aluminium	STP9060/AL/**	£118.35	
Blue	STP9060/BL/**	£189.25	
Red	STP9060/RD/**	£189.25	
Green	STP9060/GR/**	£189.25	
White	STP9060/WH/**	£189.25	
Black	STP9060/BK/**	£189.25	
Wood	STP9060/LO/**	£136.11	

** Please add code of colour required



Size	H 900mm W 900mm		
Aluminium	STP9090/AL/**	£152.56	
Blue	STP9090/BL/**	£213.58	
Red	STP9090/RD/**	£213.58	
Green	STP9090/GR/**	£213.58	
White	STP9090/WH/**	£213.58	
Black	STP9090/BK/**	£213.58	

** Please add code of colour required



Size	H 1200mm W 900mm		
Aluminium	STP1290/AL/**	£167.57	
Blue	STP1290/BL/**	£239.42	
Red	STP1290/RD/**	£239.42	
Green	STP1290/GR/**	£239.42	
White	STP1290/WH/**	£239.42	
Black	STP1290/BK/**	£239.42	
Wood	STP1290/LO/**	£174.30	

** Please add code of colour required



Size	H 1200mm W 1200mm		
Aluminium	STP1212/AL/**	£194.23	
Blue	STP1212/BL/**	£281.25	
Red	STP1212/RD/**	£281.25	
Green	STP1212/GR/**	£281.25	
White	STP1212/WH/**	£281.25	
Black	STP1212/BK/**	£281.25	
Wood	STP1212/LO/**	£206.10	

** Please add code of colour required



SINGLE DOOR COLOURED FRAME



DOUBLE DOOR ALUMINIUM FRAME



SINGLE DOOR WOOD EFFECT



Size	H 1200mm		
	W 1800mm		
Aluminium	STP1812/AL/**	£298.42	
Blue	STP1812/BL/**	£404.17	
Red	STP1812/RD/**	£404.17	
Green	STP1812/GR/**	£404.17	
White	STP1812/WH/**	£404.17	
Black	STP1812/BK/**	£404.17	
Wood	STP1812/LO/**	£326.21	

** Please add code of colour required



Size	H 1200mm		
	W 2400mm		
Aluminium	STP2412/AL/**	£341.93	
Blue	STP2412/BL/**	£478.83	
Red	STP2412/RD/**	£478.83	
Green	STP2412/GR/**	£478.83	
White	STP2412/WH/**	£478.83	
Black	STP2412/BK/**	£478.83	
Wood	STP2412/LO/**	£376.98	

** Please add code of colour required

FRAME COLOURS



LOOP NYLON CLOTH COLOURS



Resist-a-Flame Shield® Tamperproof Noticeboards

Resist-a-Flame®
FIRE RESISTANT NOTICEBOARDS



Contemporary framed premium lockable noticeboards.

Available in Satin Aluminium, White or new Light Oak effect frames.

Heavy duty design and construction using quality hinges, locks, 3mm thick PET covers and full length glazing bars.

Single door versions can be mounted portrait or landscape.

Top hinged versions include a pair of stays to support the door whilst changing information.

2 locks per door, keyed alike.

Available in a choice of 9 Woven Cloth or 11 Eco-Colour® board colours.

All tested to the latest Reaction to Fire tests - see page 67.

SIDE HINGED



ALUMINIUM FRAME



WHITE FRAME



WOOD EFFECT FRAME



TOP HINGED



Side Hinged Tamperproof Noticeboards



Size H 900mm
W 600mm

Woven Cloth

Aluminium **55301/AL/**** £141.79
White **55301/WH/**** £202.92

Eco-Colour®

Aluminium **30232/AL/**** £126.59
White **30232/WH/**** £195.08
Wood **30232/LO/**** £159.08



Size H 900mm
W 900mm

Woven Cloth

Aluminium **55311/AL/**** £188.08
White **55311/WH/**** £238.42



Size H 1200mm
W 900mm

Woven Cloth

Aluminium **55321/AL/**** £198.82
White **55321/WH/**** £259.08

Eco-Colour®

Aluminium **30243/AL/**** £171.86
White **30243/WH/**** £243.08
Wood **30243/LO/**** £204.75



Size H 1200mm
W 1200mm

Woven Cloth

Aluminium **55331/AL/**** £236.42
White **55331/WH/**** £309.75

Eco-Colour®

Aluminium **30244/AL/**** £205.99
White **30244/WH/**** £292.58
Wood **30244/LO/**** £261.43

Top Hinged Tamperproof Noticeboards



Size H 600mm
W 900mm

Woven Cloth

Aluminium **57301/AL/**** £164.25
White **57301/WH/**** £292.42

Eco-Colour®

Aluminium **30301/AL/**** £166.42
White **30301/WH/**** £286.75
Wood **30301/LO/**** £260.08



Size H 900mm
W 900mm

Woven Cloth

Aluminium **57302/AL/**** £218.25
White **57302/WH/**** £352.42

** Please add code of colour required



Size H 900mm
W 1200mm

Woven Cloth

Aluminium **57303/AL/**** £226.92
White **57303/WH/**** £372.08

Eco-Colour®

Aluminium **30303/AL/**** £221.50
White **30303/WH/**** £356.25
Wood **30303/LO/**** £317.92

** Please add code of colour required



Size H 1200mm
W 900mm

Woven Cloth

Aluminium **57304/AL/**** £215.92
White **57304/WH/**** £354.42

Eco-Colour®

Aluminium **30304/AL/**** £209.93
White **30304/WH/**** £338.58
Wood **30304/LO/**** £300.25

** Please add code of colour required

** Please add code of colour required



Size H 1200mm
W 1800mm

Woven Cloth

Aluminium **55341/AL/**** £366.67
White **55341/WH/**** £477.50

Eco-Colour®

Aluminium **30264/AL/**** £314.23
White **30264/WH/**** £421.08
Wood **30264/LO/**** £395.46



Size H 1200mm
W 2400mm

Woven Cloth

Aluminium **55351/AL/**** £431.85
White **55351/WH/**** £548.83

Eco-Colour®

Aluminium **30284/AL/**** £371.05
White **30284/WH/**** £508.83
Wood **30284/LO/**** £454.04

WOVEN CLOTH COLOURS



ECO-COLOUR BOARD COLOURS



Size H 1200mm
W 1200mm

Woven Cloth

Aluminium **57305/AL/**** £236.42
White **57305/WH/**** £385.92

Eco-Colour®

Aluminium **30305/AL/**** £230.02
White **30305/WH/**** £368.92
Wood **30305/LO/**** £325.25



Size* H 900mm
W 1800mm

Woven Cloth

Aluminium **5536/AL/**** £443.67
White **5536/WH/**** £712.00

* Double door top hinged units are delivered in two parts for ease of installation.



Size* H 1200mm
W 1800mm

Woven Cloth

Aluminium **5538/AL/**** £439.00
White **5538/WH/**** £716.00

Eco-Colour®

Aluminium **3038/AL/**** £427.02
White **3038/WH/**** £684.33
Wood **3038/LO/**** £598.92



Size* H 1200mm
W 2400mm

Woven Cloth

Aluminium **5537/AL/**** £480.00
White **5537/WH/**** £779.00

Eco-Colour®

Aluminium **3037/AL/**** £457.54
White **3037/WH/**** £735.33
Wood **3037/LO/**** £648.00

** Please add code of colour required

** Please add code of colour required

** Please add code of colour required

** Please add code of colour required

ALUMINIUM FRAME



Resist-a-Flame Shield® Showcase with Lift-off Covers

ECO-COLOUR BOARD COLOURS



Multi-panel covered noticeboard.

Each panel is supplied with its own lockable door (matching keys) and can be individually coloured.

Available in three panel sizes, to accommodate 4, 9 or 12 sheets of A4 paper per panel.

Banked in 1, 2, 3 or 4 panels.

Lockable covers lift off to easily change the material on display.

Supplied fully assembled and ready to mount.

WHITE FRAME



Size H 735mm
W 491mm

Takes 4 x A4

Aluminium **LCS1/AL/**** £135.25

White **LCS1/WH/**** £144.67



Size H 735mm
W 994mm

Takes 8 x A4

Aluminium **LCS2/AL/**** £254.25

White **LCS2/WH/**** £283.63



Size H 735mm
W 1497mm

Takes 12 x A4

Aluminium **LCS3/AL/**** £351.92

White **LCS3/WH/**** £383.31



Size H 735mm
W 2000mm

Takes 16 x A4

Aluminium **LCS4/AL/**** £431.75

White **LCS4/WH/**** £472.36



Size H 1037mm
W 720mm

Takes 9 x A4

Aluminium **LCM1/AL/**** £169.25

White **LCM1/WH/**** £180.54



Size H 1037mm
W 1446mm

Takes 18 x A4

Aluminium **LCM2/AL/**** £312.92

White **LCM2/WH/**** £339.98



Size H 1037mm
W 2172mm

Takes 27 x A4

Aluminium **LCM3/AL/**** £444.92

White **LCM3/WH/**** £482.52



Size H 1037mm
W 2898mm

Takes 36 x A4

Aluminium **LCM4/AL/**** £556.25

White **LCM4/WH/**** £604.27



Size H 1037mm
W 936mm

Takes 12 x A4

Aluminium **LCL1/AL/**** £204.08

White **LCL1/WH/**** £219.12



Size H 1037mm
W 1881mm

Takes 24 x A4

Aluminium **LCL2/AL/**** £372.42

White **LCL2/WH/**** £400.62



Size H 1037mm
W 2822mm

Takes 36 x A4

Aluminium **LCL3/AL/**** £534.25

White **LCL3/WH/**** £573.15

** Please add code of colour required

** Please add code of colour required

** Please add code of colour required



Resist-a-Flame Shield® Showcase with Sliding Doors

Shield® showcase with sliding glass doors that eliminates a hinged door protruding into a corridor.

Available in four sizes, each designed to accommodate 8, 12, 15 or 18 A4 sheets of paper.

This interior showcase has toughened safety glass 6mm thick and kite marked for added peace of mind.

Available in any combination of 3 frame colours with a range of 11 Eco-Colour® pinboard options.

All tested to the latest Reaction to Fire tests - see page 67.



ECO-COLOUR BOARD COLOURS



Resist-a-Flame®
FIRE RESISTANT NOTICEBOARDS

ALUMINIUM FRAME



WHITE FRAME



WOOD EFFECT FRAME



Size	H	W	Takes
	750mm	967mm	8 x A4
Aluminium			SBS8/AL/** £325.75
White			SBS8/WH/** £388.08
Wood			SBS8/LO/** £357.92

** Please add code of colour required



Size	H	W	Takes
	1050mm	1012mm	12 x A4
Aluminium			SBS12/AL/** £359.67
White			SBS12/WH/** £426.50
Wood			SBS12/LO/** £393.33

** Please add code of colour required



Size	H	W	Takes
	1050mm	1182mm	15 x A4
Aluminium			SBS15/AL/** £424.67
White			SBS15/WH/** £494.17
Wood			SBS15/LO/** £468.33

** Please add code of colour required



Size	H	W	Takes
	1050mm	1397mm	18 x A4
Aluminium			SBS18/AL/** £478.33
White			SBS18/WH/** £552.33
Wood			SBS18/LO/** £500.00

** Please add code of colour required



DOOR HELD OPEN WITH SUPPORT STAYS



ALUMINIUM FRAME



COLOURED FRAME



WOOD EFFECT FRAME



Shield® Showcase with Top Hinged Doors



High quality, contemporary design and superb finish make the Shield Showcase a market leading solution.

Available in a choice of 7 sizes, each designed to occupy a given number of A4 sheets of paper from two to as many as eighteen.

Top hinged doors include support stays and are fitted with two locks (matching keys).

7 frame colours and 18 loop nylon cloth colours.

FRAME COLOURS



ALUMINIUM BLUE



RED GREEN



WHITE BLACK



WOOD

LOOP NYLON CLOTH COLOURS



INK NAVY ROYAL BLUEBERRY DK WINE SCARLET YELLOW

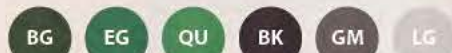

BOTTLE EMERALD QUINCE BLACK GUNMETAL LT GREY



PURPLE MAGENTA LILAC ORANGE CYAN APPLE



Size	H 570mm W 712mm
Takes	4 x A4 landscape
Aluminium	SCL4/AL/** £193.28
Blue	SCL4/BL/** £218.00
Red	SCL4/RD/** £218.00
Green	SCL4/GR/** £218.00
White	SCL4/WH/** £218.00
Black	SCL4/BK/** £218.00
Wood	SCL4/LO/** £192.16

** Please add code of colour required



Size	H 750mm W 537mm
Takes	4 x A4 portrait
Aluminium	SCP4/AL/** £188.57
Blue	SCP4/BL/** £203.00
Red	SCP4/RD/** £203.00
Green	SCP4/GR/** £203.00
White	SCP4/WH/** £203.00
Black	SCP4/BK/** £203.00
Wood	SCP4/LO/** £184.56

** Please add code of colour required



Size	H 750mm W 967mm
Takes	8 x A4
Aluminium	SCL8/AL/** £244.06
Blue	SCL8/BL/** £247.00
Red	SCL8/RD/** £247.00
Green	SCL8/GR/** £247.00
White	SCL8/WH/** £247.00
Black	SCL8/BK/** £247.00
Wood	SCL8/LO/** £244.38

** Please add code of colour required



Size	H 1050mm W 752mm
Takes	9 x A4
Aluminium	SCP8/AL/** £242.50
Blue	SCP8/BL/** £257.00
Red	SCP8/RD/** £257.00
Green	SCP8/GR/** £257.00
White	SCP8/WH/** £257.00
Black	SCP8/BK/** £257.00
Wood	SCP8/LO/** £239.75

** Please add code of colour required



Size	H 1050mm W 1012mm
Takes	12 x A4
Aluminium	SCP12/AL/** £284.39
Blue	SCP12/BL/** £327.00
Red	SCP12/RD/** £327.00
Green	SCP12/GR/** £327.00
White	SCP12/WH/** £327.00
Black	SCP12/BK/** £327.00
Wood	SCP12/LO/** £283.47

** Please add code of colour required



Size	H 1050mm W 1182mm
Takes	15 x A4
Aluminium	SCP15/AL/** £302.43
Blue	SCP15/BL/** £329.00
Red	SCP15/RD/** £329.00
Green	SCP15/GR/** £329.00
White	SCP15/WH/** £329.00
Black	SCP15/BK/** £329.00
Wood	SCP15/LO/** £300.69

** Please add code of colour required



Size	H 1050mm W 1397mm
Takes	18 x A4
Aluminium	SCP18/AL/** £338.11
Blue	SCP18/BL/** £369.00
Red	SCP18/RD/** £369.00
Green	SCP18/GR/** £369.00
White	SCP18/WH/** £369.00
Black	SCP18/BK/** £369.00
Wood	SCP18/LO/** £334.58

** Please add code of colour required



Illuminated models available
Please ask for details



Resist-a-Flame Shield Eco-Colour® Showcase

Available in a choice of 7 sizes, each designed to occupy a given number of A4 sheets of paper from two to as many as eighteen.

Top hinged doors include support stays and are fitted with two locks (matching keys).

7 frame colours and 11 Eco-Colour® pinboard colours.

All tested to the latest Reaction to Fire tests - see yellow panel.



FRAME COLOURS



ECO-COLOUR BOARD COLOURS



European reaction to fire test

Resist-a-Flame®
FIRE RESISTANT NOTICEBOARDS

Resist-a-Flame® noticeboard construction has been tested and classified to European 'Reaction to Fire' test standard and is suitable for use within sensitive public areas such as corridors, stairways and entrances.

The cloth and pinboard core assembly is classified as B according to BS EN 13501-1.

This identifies that these products can be used in the same areas as products tested to BS476 Parts 6 & 7 and classified as 0.

Lockable models have clear covers tested separately to BS476 Part 7 and classified as Class 1. Made in UK.

Size	H 570mm W 712mm	Size	H 750mm W 537mm	Size	H 750mm W 967mm	Size	H 1050mm W 752mm
Takes	4 x A4 landscape	Takes	4 x A4 portrait	Takes	8 x A4	Takes	9 x A4
Aluminium	SCBL4/AL/** £179.42	Aluminium	SCBP4/AL/** £174.75	Aluminium	SCBL8/AL/** £235.58	Aluminium	SCBP8/AL/** £281.58
Blue	SCBL4/BL/** £207.92	Blue	SCBP4/BL/** £200.75	Blue	SCBL8/BL/** £276.92	Blue	SCBP8/BL/** £319.58
Red	SCBL4/RD/** £207.92	Red	SCBP4/RD/** £200.75	Red	SCBL8/RD/** £276.92	Red	SCBP8/RD/** £319.58
Green	SCBL4/GR/** £207.92	Green	SCBP4/GR/** £200.75	Green	SCBL8/GR/** £276.92	Green	SCBP8/GR/** £319.58
White	SCBL4/WH/** £207.92	White	SCBP4/WH/** £200.75	White	SCBL8/WH/** £276.92	White	SCBP8/WH/** £319.58
Black	SCBL4/BK/** £207.92	Black	SCBP4/BK/** £200.75	Black	SCBL8/BK/** £276.92	Black	SCBP8/BK/** £319.58
Wood	SCBL4/LO/** £188.75	Wood	SCBP4/LO/** £183.25	Wood	SCBL8/LO/** £247.92	Wood	SCBP8/LO/** £294.08

** Please add code of colour required

** Please add code of colour required

** Please add code of colour required

** Please add code of colour required



Illuminated models available
Please ask for details



Size	H 1050mm W 1012mm
Takes	12 x A4
Aluminium	SCBP12/AL/** £288.42
Blue	SCBP12/BL/** £338.58
Red	SCBP12/RD/** £338.58
Green	SCBP12/GR/** £338.58
White	SCBP12/WH/** £338.58
Black	SCBP12/BK/** £338.58
Wood	SCBP12/LO/** £302.25

** Please add code of colour required



Size	H 1050mm W 1182mm
Takes	15 x A4
Aluminium	SCBP15/AL/** £302.58
Blue	SCBP15/BL/** £353.42
Red	SCBP15/RD/** £353.42
Green	SCBP15/GR/** £353.42
White	SCBP15/WH/** £353.42
Black	SCBP15/BK/** £353.42
Wood	SCBP15/LO/** £316.25

** Please add code of colour required



Size	H 1050mm W 1397mm
Takes	18 x A4
Aluminium	SCBP18/AL/** £348.75
Blue	SCBP18/BL/** £403.75
Red	SCBP18/RD/** £403.75
Green	SCBP18/GR/** £403.75
White	SCBP18/WH/** £403.75
Black	SCBP18/BK/** £403.75
Wood	SCBP18/LO/** £360.92

** Please add code of colour required

Shield® Exterior Showcase

Market leading exterior showcase offering coloured frame options and a contemporary design.

Independently certified to ip55 requirements of EN60529 against water and dust ingress.

Available in a choice of 7 sizes, each designed to occupy a given number of A4 sheets of paper.

Top hinged doors include support stays and are fitted with two locks with matching keys.

A choice of 7 frame colours combine with any of 18 exterior cloth options, or traditional pinnable cork.

See over page for Post Mounted versions.



FRAME COLOURS



LOOP NYLON CLOTH COLOURS



ALUMINIUM FRAME



WOOD EFFECT FRAME



Size H 570mm
W 712mm
Takes 4 x A4 landscape
Aluminium **SCEL4/AL/**** £205.44

Blue **SCEL4/BL/**** £226.97
Red **SCEL4/RD/**** £226.97
Green **SCEL4/GR/**** £226.97
White **SCEL4/WH/**** £226.97
Black **SCEL4/BK/**** £226.97

Wood **SCEL4/LO/**** £198.64



Size H 750mm
W 537mm
Takes 4 x A4 portrait
Aluminium **SCEP4/AL/**** £199.95

Blue **SCEP4/BL/**** £219.94
Red **SCEP4/RD/**** £219.94
Green **SCEP4/GR/**** £219.94
White **SCEP4/WH/**** £219.94
Black **SCEP4/BK/**** £219.94

Wood **SCEP4/LO/**** £196.56



Size H 750mm
W 967mm
Takes 8 x A4
Aluminium **SCEL8/AL/**** £265.83

Blue **SCEL8/BL/**** £299.38
Red **SCEL8/RD/**** £299.38
Green **SCEL8/GR/**** £299.38
White **SCEL8/WH/**** £299.38
Black **SCEL8/BK/**** £299.38

Wood **SCEL8/LO/**** £249.94



Size H 1050mm
W 752mm
Takes 9 x A4
Aluminium **SCEP8/AL/**** £261.32

Blue **SCEP8/BL/**** £283.64
Red **SCEP8/RD/**** £283.64
Green **SCEP8/GR/**** £283.64
White **SCEP8/WH/**** £283.64
Black **SCEP8/BK/**** £283.64

Wood **SCEP8/LO/**** £249.75

** Please add code of colour required



Size H 1050mm
W 1012mm
Takes 12 x A4
Aluminium **SCEP12/AL/**** £304.19

Blue **SCEP12/BL/**** £345.51
Red **SCEP12/RD/**** £345.51
Green **SCEP12/GR/**** £345.51
White **SCEP12/WH/**** £345.51
Black **SCEP12/BK/**** £345.51

Wood **SCEP12/LO/**** £296.06

** Please add code of colour required



Size H 1050mm
W 1182mm
Takes 15 x A4
Aluminium **SCEP15/AL/**** £317.33

Blue **SCEP15/BL/**** £362.92
Red **SCEP15/RD/**** £362.92
Green **SCEP15/GR/**** £362.92
White **SCEP15/WH/**** £362.92
Black **SCEP15/BK/**** £362.92

Wood **SCEP15/LO/**** £310.88

** Please add code of colour required



Size H 1050mm
W 1397mm
Takes 18 x A4
Aluminium **SCEP18/AL/**** £359.09

Blue **SCEP18/BL/**** £405.88
Red **SCEP18/RD/**** £405.88
Green **SCEP18/GR/**** £405.88
White **SCEP18/WH/**** £405.88
Black **SCEP18/BK/**** £405.88

Wood **SCEP18/LO/**** £348.29

** Please add code of colour required

Illuminated models, using cold cathode lights at the top of the units, are available upon request.



** Please add code of colour required

Shield® Exterior Post Mounted Showcase



Market leading exterior showcase offering coloured frame options and a contemporary design.

Independently certified to ip55 requirements of EN60529 against water and dust ingress.

Available in a choice of 4 sizes, each designed to occupy a given number of A4 sheets of paper.

Top hinged doors include support stays and are fitted with two locks with matching keys.

A choice of 7 frame colours combine with any of 18 exterior cloth options, or traditional pinnable cork.



FRAME COLOURS



LOOP NYLON CLOTH COLOURS

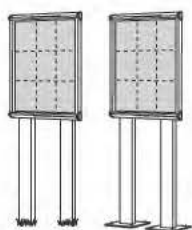

Size H 1050mm
W 752mm
Takes 9 x A4

Showcase with Sunken Posts

Aluminium	SCES8/AL/**	£501.05
Blue	SCES8/BL/**	£543.86
Red	SCES8/RD/**	£543.86
Green	SCES8/GR/**	£543.86
White	SCES8/WH/**	£543.86
Black	SCES8/BK/**	£543.86
Wood	SCES8/LO/**	£513.68

Showcase with Bolt Down Posts

Aluminium	SCEB8/AL/**	£493.68
Blue	SCEB8/BL/**	£536.32
Red	SCEB8/RD/**	£536.32
Green	SCEB8/GR/**	£536.32
White	SCEB8/WH/**	£536.32
Black	SCEB8/BK/**	£536.32
Wood	SCEB8/LO/**	£506.32

Extra showcase for double sided

Aluminium	SCED8/AL/**	£334.74
Blue	SCED8/BL/**	£377.37
Red	SCED8/RD/**	£377.37
Green	SCED8/GR/**	£377.37
White	SCED8/WH/**	£377.37
Black	SCED8/BK/**	£377.37
Wood	SCED8/LO/**	£338.44

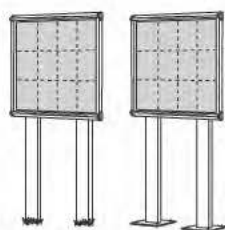

Size H 1050mm
W 1012mm
Takes 12 x A4

Showcase with Sunken Posts

Aluminium	SCES12/AL/**	£550.35
Blue	SCES12/BL/**	£607.89
Red	SCES12/RD/**	£607.89
Green	SCES12/GR/**	£607.89
White	SCES12/WH/**	£607.89
Black	SCES12/BK/**	£607.89
Wood	SCES12/LO/**	£567.19

Showcase with Bolt Down Posts

Aluminium	SCEB12/AL/**	£539.65
Blue	SCEB12/BL/**	£594.74
Red	SCEB12/RD/**	£594.74
Green	SCEB12/GR/**	£594.74
White	SCEB12/WH/**	£594.74
Black	SCEB12/BK/**	£594.74
Wood	SCEB12/LO/**	£553.51

Extra showcase for double sided

Aluminium	SCED12/AL/**	£379.65
Blue	SCED12/BL/**	£437.54
Red	SCED12/RD/**	£437.54
Green	SCED12/GR/**	£437.54
White	SCED12/WH/**	£437.54
Black	SCED12/BK/**	£437.54
Wood	SCED12/LO/**	£387.74

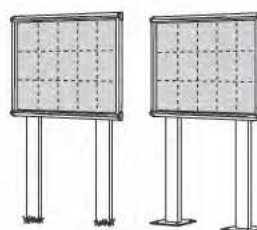

Size H 1050mm
W 1182mm
Takes 15 x A4

Showcase with Sunken Posts

Aluminium	SCES15/AL/**	£571.40
Blue	SCES15/BL/**	£628.25
Red	SCES15/RD/**	£628.25
Green	SCES15/GR/**	£628.25
White	SCES15/WH/**	£628.25
Black	SCES15/BK/**	£628.25
Wood	SCES15/LO/**	£588.25

Showcase with Bolt Down Posts

Aluminium	SCEB15/AL/**	£563.16
Blue	SCEB15/BL/**	£619.82
Red	SCEB15/RD/**	£619.82
Green	SCEB15/GR/**	£619.82
White	SCEB15/WH/**	£619.82
Black	SCEB15/BK/**	£619.82
Wood	SCEB15/LO/**	£580.18

Extra showcase for double sided

Aluminium	SCED15/AL/**	£422.11
Blue	SCED15/BL/**	£478.77
Red	SCED15/RD/**	£478.77
Green	SCED15/GR/**	£478.77
White	SCED15/WH/**	£478.77
Black	SCED15/BK/**	£478.77
Wood	SCED15/LO/**	£430.37

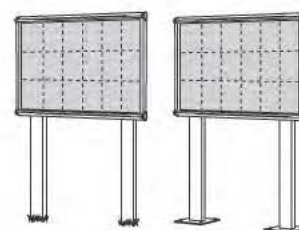

Size H 1050mm
W 1397mm
Takes 18 x A4

Showcase with Sunken Posts

Aluminium	SCES18/AL/**	£625.96
Blue	SCES18/BL/**	£690.70
Red	SCES18/RD/**	£690.70
Green	SCES18/GR/**	£690.70
White	SCES18/WH/**	£690.70
Black	SCES18/BK/**	£690.70
Wood	SCES18/LO/**	£642.81

Showcase with Bolt Down Posts

Aluminium	SCEB18/AL/**	£618.60
Blue	SCEB18/BL/**	£679.47
Red	SCEB18/RD/**	£679.47
Green	SCEB18/GR/**	£679.47
White	SCEB18/WH/**	£679.47
Black	SCEB18/BK/**	£679.47
Wood	SCEB18/LO/**	£635.61

Extra showcase for double sided

Aluminium	SCED18/AL/**	£463.51
Blue	SCED18/BL/**	£520.53
Red	SCED18/RD/**	£520.53
Green	SCED18/GR/**	£520.53
White	SCED18/WH/**	£520.53
Black	SCED18/BK/**	£520.53
Wood	SCED18/LO/**	£467.74

** Please add code of colour required

** Please add code of colour required

** Please add code of colour required

** Please add code of colour required



Double Sided Mobile Noticeboards

An aluminium framed mobile noticeboard with locking castors.

Double sided height adjustable aluminium framed noticeboard is mounted on a stable powder coated steel stand.

Available in a choice of 6 sizes.

Standard Felt or Resist-a-Flame® versions.

Resist-a-Flame Eco-Colour®

Fire resistant board tested to meet the latest building and fire regulations.



Board Size H 900mm
W 1200mm
Height 1875mm
Felt **M391L/**** **£212.00**
Resist-a-Flame® **MR34L/**** **£227.17**



Board Size H 1200mm
W 900mm
Height 2030mm
Felt **M391P/**** **£208.33**
Resist-a-Flame® **MR43P/**** **£223.50**



Board Size H 1200mm
W 1200mm
Height 2030mm
Felt **M401S/**** **£221.33**
Resist-a-Flame® **MR44S/**** **£232.00**

STANDARD FELT CLOTH



BLUE RED GREEN



GREY BURGUNDY

RESIST-A-FLAME ECO-COLOUR®



BLUE RED GREEN



CHARCOAL RASPBERRY



Board Size H 1200mm
W 1500mm
Height 2030mm
Felt **M454L/**** **£236.00**
Resist-a-Flame® **MR45L/**** **£253.33**



Board Size H 1500mm
W 1200mm
Height 2130mm
Felt **M454P/**** **£233.83**
Resist-a-Flame® **MR54P/**** **£251.33**



Board Size H 1200mm
W 1800mm
Height 2000mm
Felt **M411L/**** **£247.00**
Resist-a-Flame® **MR64L/**** **£285.50**

** Please add code of colour required

** Please add code of colour required

** Please add code of colour required

Shield® Design Foyer Noticeboards



Adjustable bracket enables the noticeboard to be mounted from vertical to 45° angle in landscape or portrait.

Satin aluminium or white frame on an aluminium post and sturdy grey steel base.

Available with a choice of 18 cloth options or traditional cork.

Accepts pins or Velcro®.

1m stand height to centre of the noticeboard.

LOOP NYLON CLOTH COLOURS



	Board Size	H 600mm	W 450mm
	Aluminium	SNL005/AL/**	£164.83
	White	SNL005/WH/**	£183.83

** Please add code of colour required

	Board Size	H 900mm	W 600mm
	Aluminium	SNL015/AL/**	£170.67
	White	SNL015/WH/**	£192.33

** Please add code of colour required

Height Adjustable Mobile Noticeboards

Double sided mobile pinnable panels framed in anodised aluminium and mounted on sturdy white frame with locking castors.

These height adjustable panels can be mounted in either portrait or landscape formats.

Pinnable noticeboards are available in a choice of blue, red, green or grey cloth.

Drywipe whiteboard option also available, one side is plain, reverse has a faint Guideline® grid.

LOOP NYLON CLOTH COLOURS



Board Size	H 1200mm	W 900mm
Loop Nylon	MNB43/**	£174.39
Whiteboard	MWB43	£160.18

** Please add code of colour required



Board Size	H 1200mm	W 1200mm
Loop Nylon	MNB44/**	£184.91
Whiteboard	MWB44	£170.53

** Please add code of colour required



Board Size	H 1500mm	W 1200mm
Loop Nylon	MNB54/**	£202.98
Whiteboard	MWB54	£188.95

** Please add code of colour required



Board Size	H 1800mm	W 1200mm
Loop Nylon	MNB64/**	£213.51
Whiteboard	MWB64	£201.40

** Please add code of colour required



Combi Mobile Information Board



Mobile double sided board offering both pinboard and whiteboard applications in one product.

Available in Blue or Grey felt cloth.

Height adjustable.

Whiteboard surface accepts magnets.

Available in two popular sizes.

Stable powder coated steel frame with 4 castors, 2 lockable.

A1 flip pad clamp on whiteboards - see page 39.



Board Size H 1200mm
W 700mm
Grey **448050** **£134.53**
Blue **448052** **£134.53**



Board Size H 1000mm
W 1000mm
Grey **448051** **£143.52**



Wood Mobile Noticeboard/Dividers

Double sided boards available in 3 sizes of loop nylon faced noticeboard or drywipe whiteboard.

Heavy duty frame made from quality lacquered beech sourced from sustainable forests.

Board edges are rounded for increased safety.

Heavy duty wooden feet ensure stability when free standing; wheels are provided if mobility is required.

Whiteboard version features a plain drywipe surface to one side, while the reverse has a feint Guideline® grid to aid writing.



Size H 1200mm
W 1200mm
Blue **DJS44/BL** **£317.50**
Red **DJS44/RD** **£317.50**
Whiteboard **DJS44/WB** **£310.00**



Size H 1200mm
W 1800mm
Blue **DJS46/BL** **£365.97**
Red **DJS46/RD** **£365.97**
Whiteboard **DJS46/WB** **£363.06**



Size H 1800mm
W 1200mm
Blue **DJS64/BL** **£365.97**
Red **DJS64/RD** **£365.97**
Whiteboard **DJS64/WB** **£363.06**

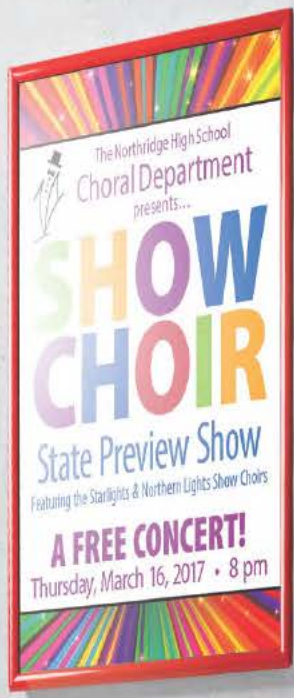

ALUMINIUM



BLUE



RED



GREEN



WHITE



BLACK



STAINLESS STEEL EFFECT



WOOD EFFECT

BusyGrip® Aluminium and Coloured Poster Frames



Wide range of popular sized aluminium poster frames in a range of 8 colour finishes.

The 25mm wide frames simply snap open and closed to change the poster.

Poster is protected by anti glare UV resistant cover.

Mount portrait or landscape with fixings provided.

Available in 7 sizes to take all 'A' sized posters between A4 and A0 plus the most popular 'B' sized posters.

25mm wide frame profile, please add 50mm to dimensions stated for the external frame measurement.

Designed for internal use, please see page 89 for external poster frames.



Size A4	H	297mm
	W	210mm
Profile		25mm
Aluminium	PFA4/AL	£16.62
Blue	PFA4/BL	£20.34
Red	PFA4/RD	£20.34
Green	PFA4/GR	£20.34
White	PFA4/WH	£20.34
Black	PFA4/BK	£20.34
Stainless Steel	PFA4/SS	£26.34
Wood Effect	PFA4/WD	£27.33



Size A3	H	420mm
	W	297mm
Profile		25mm
Aluminium	PFA3/AL	£21.43
Blue	PFA3/BL	£26.40
Red	PFA3/RD	£26.40
Green	PFA3/GR	£26.40
White	PFA3/WH	£26.40
Black	PFA3/BK	£26.40
Stainless Steel	PFA3/SS	£32.94
Wood Effect	PFA3/WD	£34.00



Size A2	H	594mm
	W	420mm
Profile		25mm
Aluminium	PFA2/AL	£31.22
Blue	PFA2/BL	£37.95
Red	PFA2/RD	£37.95
Green	PFA2/GR	£37.95
White	PFA2/WH	£37.95
Black	PFA2/BK	£37.95
Stainless Steel	PFA2/SS	£44.22
Wood Effect	PFA2/WD	£45.11

Please add 50mm to the dimensions given for the external measurements of the poster frame



Size A1	H	840mm
	W	594mm
Profile		25mm
Aluminium	PFA1/AL	£44.83
Blue	PFA1/BL	£54.12
Red	PFA1/RD	£54.12
Green	PFA1/GR	£54.12
White	PFA1/WH	£54.12
Black	PFA1/BK	£54.12
Stainless Steel	PFA1/SS	£65.42
Wood Effect	PFA1/WD	£65.19



Size A0	H	1189mm
	W	840mm
Profile		25mm
Aluminium	PFA0/AL	£75.44
Blue	PFA0/BL	£88.19
Red	PFA0/RD	£88.19
Green	PFA0/GR	£88.19
White	PFA0/WH	£88.19
Black	PFA0/BK	£88.19
Stainless Steel	PFA0/SS	£102.78
Wood Effect	PFA0/WD	£98.76



Size B2	H	700mm
	W	500mm
Profile		25mm
Aluminium	PFB2/AL	£33.81
Blue	PFB2/BL	£41.63
Red	PFB2/RD	£41.63
Green	PFB2/GR	£41.63
White	PFB2/WH	£41.63
Black	PFB2/BK	£41.63
Stainless Steel	PFB2/SS	£52.38
Wood Effect	PFB2/WD	£52.69



Size B1	H	1000mm
	W	700mm
Profile		25mm
Aluminium	PFB1/AL	£59.98
Blue	PFB1/BL	£70.71
Red	PFB1/RD	£70.71
Green	PFB1/GR	£70.71
White	PFB1/WH	£70.71
Black	PFB1/BK	£70.71
Stainless Steel	PFB1/SS	£81.39
Wood Effect	PFB1/WD	£80.15



BusyGrip® Certificate Frames



Available in 3 finishes to suit your environment; natural wood look, contemporary black or traditional anodised aluminium.

The frames simply mount to a wall with the fixings supplied or open the integral stand for desktop use.

They can be used portrait or landscape for both wall or freestanding.

The frames simply snap open and closed to insert or change the certificates which are also protected by anti-glare UV resistant cover.

Black
 Size A4 H 297mm
 W 210mm
 Profile 25mm
 Code **LD1085**
£20.64

Aluminium
 Size A4 H 297mm
 W 210mm
 Profile 25mm
 Code **LD1086**
£17.00

Wood
 Size A4 H 297mm
 W 210mm
 Profile 25mm
 Code **LD1087**
£26.44



BusyGrip® Multiple A4 Frames

Contemporary mix of anodised and black coated aluminium frame enhances the display of multiple A4 sheets.

Each A4 sheet is held securely in position with the transparent clip system; no pinning or velcro required.

The frames simply snap open and closed to insert or change the sheets as required.

Contents are protected by anti-glare UV resistant cover.



Size H 694mm
 W 522mm
 Takes 4 x A4
 Profile 40mm
 Code **LD3070**
£59.67



Size H 694mm
 W 742mm
 Takes 6 x A4
 Profile 40mm
 Code **LD3071**
£75.07



Size H 999mm
 W 742mm
 Takes 9 x A4
 Profile 40mm
 Code **LD3072**
£86.89





BusyGrip® External Poster Cases

This snap frame is fitted with a weatherproof seal preventing water damage.

The special frame profile and higher strength springs prevent casual tampering as a unique tool is required to open the frame.

Supplied with opening tool.

UV protective film prevents fading.

BusyGrip® Locking Poster Cases

These weather resistant locking poster cases are designed to take standard paper sizes.

Ideal for public information.

Clips inside the case hold paper securely.

Single lock on 3 smaller sizes, 2 on the rest.



Size A4 H 297mm
W 210mm
Profile 32mm
External **EPF1000**
£42.57
Locking **LPC1000**
£71.55



Size A3 H 420mm
W 297mm
Profile 32mm
External **EPF1001**
£48.00
Locking **LPC1001**
£91.65



Size A2 H 594mm
W 420mm
Profile 32mm
External **EPF1002**
£59.23
Locking **LPC1002**
£119.99



Size A1 H 840mm
W 594mm
Profile 32mm
External **EPF1003**
£82.17
Locking **LPC1003**
£171.68



Size A0 H 1189mm
W 840mm
Profile 32mm
External **EPF1004**
£134.12
Locking **LPC1004**
£263.37

EXTERNAL



LOCKING



Size H 700mm
W 500mm
Profile 32mm
External **EPF1005**
£69.63
Locking **LPC1005**
£131.35



Size H 1000mm
W 700mm
Profile 32mm
External **EPF1006**
£106.10
Locking **LPC1006**
£210.75

BusyGrip® Standard Information Stands

Stylish single height freestanding poster frames which have adjustment for viewing angle and orientation.

Aluminium post combines with a sturdy steel base to provide stability.

Available in A4 or A3 with satin anodised aluminium snap frames which can be rotated to be used portrait or landscape.



Size A4 H 297mm
W 210mm
Height Port. 1010mm
Height Land. 967mm
Code **LD1073**
£88.91



Size A3 H 420mm
W 297mm
Height Port. 1076mm
Height Land. 1014mm
Code **LD1074**
£119.02

BusyGrip® Telescopic Information Stands

Freestanding poster frame which is adjustable in height, angle and orientation.

Telescopic aluminium post allows the frame to be height adjustable by 340mm.

Available in A4 or A3 with satin anodised aluminium snap frames which can be rotated to be used portrait or landscape.

Frames can also be viewed at any angle between horizontal and vertical.

Sturdy steel base provides stability.

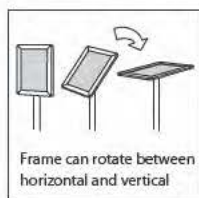

Size A4 H 297mm
W 210mm
Height Port. 910-1250mm
Height Land. 865-1205mm
Code **LD1071**
£148.00



Size A3 H 420mm
W 297mm
Height Port. 970-1310mm
Height Land. 910-1250mm
Code **LD1072**
£199.00



BusyGrip® Black Poster Stands

Attractive curved black stand holds A4 or A3 sized frames to display menus, sales literature etc.

Snap frame is mounted at the optimum viewing angle and adjusts for horizontal or portrait orientation.

The coated curved aluminium post is attached to a stable steel base.



Size A4 H 297mm
W 210mm
Height Port. 1212mm
Height Land. 1176mm
Code **LD1063**
£153.08



Size A3 H 420mm
W 297mm
Height Port. 1262mm
Height Land. 1212mm
Code **LD1064**
£155.50



BusyGrip® Black Illuminated Poster Stands

LED edge lit acrylic poster stand in black.

Curved black stands hold an A4 or A3 sized frame to illuminate menus, sales literature etc.

The frame is mounted at the optimum viewing angle and can be adjusted for horizontal or portrait orientation.

Stable steel base.

Integrated on-off switch at the rear of the unit CE tested, with 3.5m cable and UK plug.



Size A4 H 297mm
W 210mm
Height Port. 1250mm
Height Land. 1215mm
Code **LD1065**
£222.42



Size A3 H 420mm
W 297mm
Height Port. 1303mm
Height Land. 1250mm
Code **LD1066**
£300.96



BusyGrip® Menu or Information Stand



Lightweight stand with optional multi-page ring binder mechanism.

Use a punch to prepare the information before clipping into the integrated 4 ring binder.

Alternatively remove the binder mechanism and display the information on the 70° sloping clear acrylic platform.

1110mm high anodised aluminium post is mounted to an attractive heavy base for stability.



Size H 1110mm
W 470mm
D 320mm
Code **LD3090**
£122.20



BusyGrip® Folding 'A' Frame Poster Displays

LOCOMOITO
MEXICAN CANTINA & COCKTAIL BAR
197 BRICK LANE, LONDON E1 6SA
020 7333 4666

Starters

- 1. CIABATTA GARLIC BREAD (V) £2.95
- 2. CIABATTA GARLIC BREAD WITH CHEESE & SALAD (V) £3.45
- 3. LOUISIANA BUFFALO WINGS £3.95
- 4. RIBS TBS SAMPLER £5.95
- 5. MEXICAN SALSA DIPS (V) £4.25
- 6. FIRE BEAN & CHILLI HUMMUS DIPS (V) £4.25
- 7. BEEF CHILLI SAMPLER £4.25
- 8. CALAMARI FRIED £4.95
- 9. CREAM CHEESE JALAPENOS (V) £4.75
- 10. COLD RADO MUSHROOMS (V) £4.50
- 11. LOADED POTATO SKINS £3.95
- 12. SMOKED BACON & CHEESE £3.95
- 13. CHILLI COX CARNE & SOUR CREAM £4.25

Nachos

- 12. CLASSIC NACHOS (V) £3.95
- 13. SPICY BEEF NACHOS £4.95
- 14. CHICKEN NACHOS £4.95
- 15. CHORIZO & OLIVE NACHOS £4.95
- 20. CHORIZO & CHEESE QUESADILLA £4.50
- 21. BEEF TACOS & QUESADILLAS £5.20
- 22. PEPPY PORN BREAD PRAMING £3.50
- 23. MUSSELS IN TOMATO CHILLI SALSA £5.50

Combo Fiesta to Share

Hot, tangy, dark protein? Lure you to get blood after drinking of several bottles. Loaded with cheese, salsa, jalapenos, served with sour cream, salsa & guacamole.
Serving for 2 £6.50 - Serving for 4 £10.00

Tacos

- 17. CHILLI CHICKEN £4.95
- 18. FIRE BEAN & HUMMUS (V) £4.95
- 19. CHILLI BEEF £4.95

Drinks

- FRUIT JUICE SOFT DRINKS £2.25
- MINERAL WATER 500ml £2.00
- MINERAL WATER 1.1L £3.50
- CAPPICINO £3.95

Note

* All fresh chickens are used in our dishes, whilst pieces of bone may rarely be found in your meal.
* Minimum food charge £10.00 per person on weekends & bank holidays.



BusyGrip® Indoor 'A' Frames



A freestanding double sided poster frame that folds flat for easy portability and storage.

Frame is finished in satin anodised aluminium.

Suitable for internal or external use but not weatherproof.

Available in three popular sizes A1, B2 and B1.

Contents are protected by anti-glare UV resistant covers.

BusyGrip® Outdoor 'A' Frames



Protect your posters with this weatherproof A frame display.

The anti-glare UV resistant cover seals to the internal rubber gasket to ensure the protection of the displayed information from the elements.

The anodised aluminium snap frame is available in three popular sizes A1, B2 and B1.

The double sided stand folds flat for easy storage.



Indoor 'A' Frame

Size A1 H 841mm
W 594mm

Stand Height 1150mm

Code **AF1000**

£121.45



Indoor 'A' Frame

Size B2 H 700mm
W 500mm

Stand Height 950mm

Code **AF1001**

£104.98



Indoor 'A' Frame

Size B1 H 1000mm
W 700mm

Stand Height 1250mm

Code **AF1002**

£143.11



Outdoor 'A' Frame

Size A1 H 841mm
W 594mm

Stand Height 1050mm

Code **AF2000**

£176.58



Outdoor 'A' Frame

Size B2 H 700mm
W 500mm

Stand Height 950mm

Code **AF2001**

£148.49



Outdoor 'A' Frame

Size B1 H 1000mm
W 700mm

Stand Height 1200mm

Code **AF2002**

£219.94



BusyGrip® Chalkboard Outdoor 'A' Frames

Chalkboard inserts are protected by a clear plastic cover which seals the written message.

For use with chalk or modern water based pens.

To change the message simply open the snap frame, remove the chalkboard inserts, clean with a damp cloth and reinsert.

Folds flat for transporting and storage.

Made of lightweight yet sturdy aluminium.



Chalkboard 'A' Frame

Size A1 H 841mm
W 594mm

Stand Height 1050mm

Code **AF2004**

£197.36



Spare Inserts

Pack of 2

Size A1 H 841mm
W 594mm

Code **AF2005**

£34.93

Swinging Poster Display Pavement Signs



External double sided A2 poster stand.
 Seals an A2 poster between clear windowed sleeves.
 Sturdy stand is designed for the poster to swing freely in the wind.
 Heavy base to withstand the most inclement weather.
 Coated steel frame and heavy duty plastic base.
 Robust swinging brackets securely retain the poster holder.

Takes A2 H 594mm
 W 420mm
 Overall size H 935mm
 W 600mm
 Code **SP1000**
£148.77



BusyGrip® sprung pavement signs

Weatherproof double sided poster frame.
 Double sided large sized snap frames with weatherproof seals and UV poster protection.
 Base can be filled with water for extra stability.
 Two side wheels aid mobility when unit is angled.
 Easy self assembly.

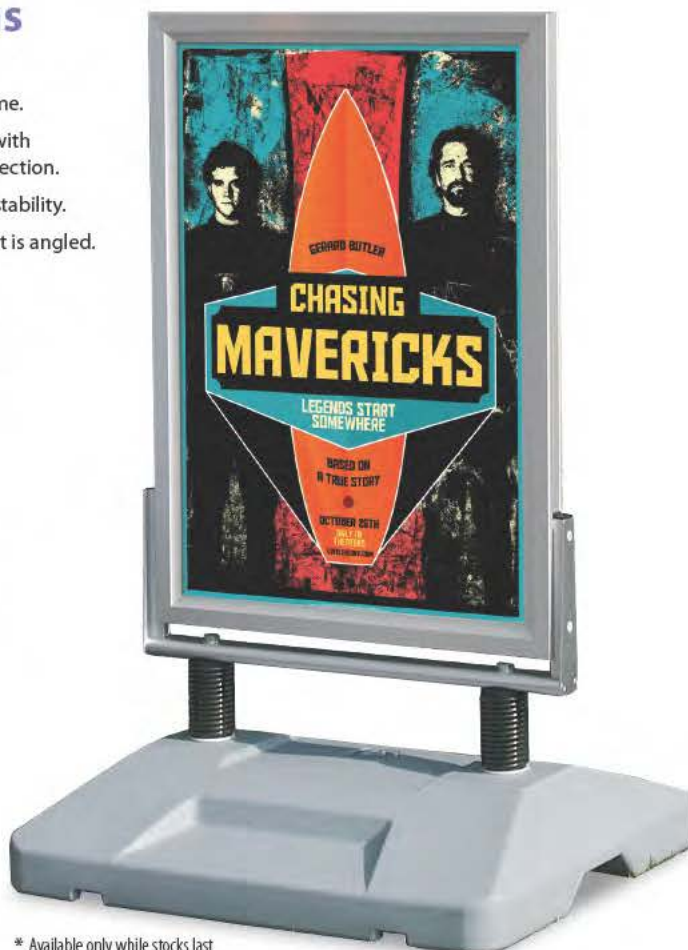

Size A1 H 841mm
 W 594mm
 Code **LD1090T**
£300.56



Size A0 H 1189mm
 W 841mm
 Code **LD1089T**
£353.42



Size H 1524mm
 W 1016mm
 Code **LD1088T***
£367.19

* Available only while stocks last

Chalkboard Pavement Sign



Double sided chalkboard stand.

This simple stand is designed with a heavy base to withstand moderate wind speed.

The chalkboard surfaces are ideal for use with chalk or modern water based pens.



Panel H 850mm
W 460mm
Overall H 870mm
W 523mm
D 490mm
Code **BP1000**
£85.75



Wood Chalkboard 'A' Frame



Traditional double sided wooden A frame chalkboard.

Suitable for displaying messages outside of restaurants, cafes, bars etc.

50mm wide wooden frame surrounds the writing surface designed for use with 'chalk' pens.

The 700 x 900mm frame folds flat for storage.

Footprint of 700 x 600mm.

Board size H 800mm
W 600mm
Height in use 1050mm
Code **LD4020**
£183.59

Freestanding Whiteboard Signs

A range of double sided signs available in three useful shapes - rectangular, octagonal and directional arrow.

The Arrow sign angles and locks in chosen position.

Whiteboard surface accepts magnets and is designed for use with drywipe markers.

Robust plastic frame, pole and circular base which can be filled with water or sand for extra stability.



Arrow

Size H 430mm
W 650mm
Stand Height 1632mm
Code **G4173BL**
£117.97

Octagon

Size H 565mm
W 565mm
Stand Height 1650mm
Code **G4118BL**
£140.94

Rectangle

Size H 645mm
W 435mm
Stand Height 1650mm
Code **G4117BL**
£140.94

Set of 3 signs
(1 of each type)

Code **G400SET**
£371.81

WriteOn® Chalkboard Pens

Wallet of 3 pens: White
439501 £27.81

Wallet of 5 pens:
1 of each Red, Yellow, Pink, Green, Orange
439500 £49.82

WriteOn® Whiteboard Pens

Wallet of 4 pens:
1 of each Black, Blue, Red, Green
439115 £6.93

Pack of 10 pens:
3 Black, 2 Blue, 3 Red, 2 Green
439116 £13.77

Other accessories
See pages 33-36



Wood Framed Chalkboards



Traditional wall mounted wood framed chalkboards.

Suitable for displaying messages in restaurants, cafes, bars etc.

For use with 'chalk' pens enabling the message to be changed when required - see page 34.

Available in 4 standard sizes up to 1.25m.

Can be mounted portrait or landscape.

50mm wooden frame is mounted with a simple fixing kit, supplied.



Size H 700mm
W 500mm
Code **LD4010**
£56.29



Size H 1000mm
W 500mm
Code **LD4011**
£52.84



Size H 900mm
W 700mm
Code **LD4012**
£84.97



Size H 1250mm
W 700mm
Code **LD4013**
£105.53

WriteOn® Chalkboard Pens
Wallet of 3 pens: White
439501 £27.81
Wallet of 5 pens:
1 of each Red, Yellow, Pink, Green, Orange
439500 £49.82
Other accessories
See pages 33-36

Wood Edged Chalkboard Signs

Contemporary styling to traditional signage.

Simply unhook the board and lay on a flat surface to assist in writing your message.

Stylish wooden edging to the chalkboard surface.

Available in 4 popular sizes.

For use with chalk or modern water based pens - see page 34.

Hooks and fixings supplied.

Ideal for use in cafés and restaurants.



Size H 600mm
W 400mm
Code **LD4030**
£55.69



Size H 900mm
W 400mm
Code **LD4031**
£72.31



Size H 800mm
W 600mm
Code **LD4032**
£90.61



Size H 1150mm
W 600mm
Code **LD4033**
£116.68



ACCEPTS CHALK PENS
SEE PAGE 34



ACCEPTS SUPER STRENGTH
MAGNETS SEE PAGE 36



WriteOn® Coloured Glass Information Boards



A range of attractive glass drywipe boards which also accept super strength magnets.

The glass board stands proud of the wall on special chrome fixings, supplied, adding to the visual impact.

Made from 4mm toughened safety glass in a choice of 10 colours with a steel back.

Ideal for restaurants, bars and reception areas.



All 10 colours

Size H 500mm
W 500mm

Code **G5050/****
£67.15

All 10 colours

Size H 600mm
W 450mm

Code **G4560/****
£70.48

White or black

Size H 900mm
W 600mm

Code **G6090/****
£112.41

White or black

Size H 1000mm
W 650mm

Code **G6510/****
£135.50

WriteOn® Glassboard Pens

Wallet of 5 pens: White

539101 **£15.00**

Wallet of 5 pens:

1 of each Black, Red, Blue, Green, Yellow

539100 **£15.00**

Magnets and other accessories

See pages 33-36

** Please add code of colour required

FOR LARGER WHITE GLASS BOARDS - SEE PAGE 6



WHITE



BLACK



RED



BLUE



YELLOW



GREY



VIOLET



SKY BLUE



ORANGE



LIME



SHOW•POINT



ShowPoint® In-Out Board

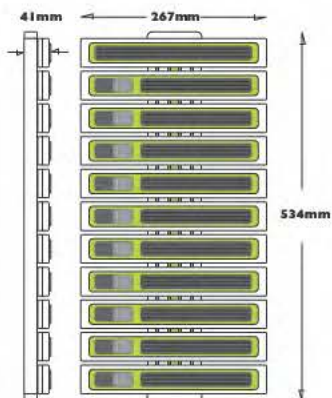

Styled in cool white with a striking accent colour.

Names can be created using -

- 1 Interchangeable letters - Supplied.
- 2 Computer generated printed strips
Header - 222 x 16mm.
Indicator - 156 x 16mm.
- 3 Hand written - Insert card and pen provided.

Supplied with easy to read characters which are up to 100% larger than some other systems.

Name plates have a clear cover to prevent casual interference.

Installation takes a matter of minutes, simply affix the mounting post to the wall and snap each of the modules in place.

Anti-tamper strips supplied to lock name plates in position for added security if required.

The versatile Showpoint® Kit can also be used as a modular directional signage system.

10 Module Kit
Size H 534mm
W 267mm
D 41mm
Code **SPSK100**
£50.00

20 Module Kit
Size H 534mm
W 534mm
D 41mm
Code **SPSK200**
£95.00

Extra Letters
Pack of 447 letters and numbers
Code **SPLN400**
£14.00

Timeminder® In-Out Message Board

This simple printed drywipe board allows you to know if a member of staff is in the building.

Can also be used to record a message if they are out or indicate where they are.

600 x 450mm blue edged drywipe board.

Simple through the board fixing and cover caps.

For use with drywipe pens.

Other printed drywipe boards and planners are featured on pages 28-29.



Size H 600mm
W 450mm
Code **46836**
£39.93



WriteOn® Whiteboard Pens

Wallet of 4 pens:

1 of each Black, Blue, Red, Green

439115 **£6.93**

Pack of 10 pens:

3 Black, 2 Blue, 3 Red, 2 Green

439116 **£13.77**

Other accessories

See pages 33-36

ShowPoint® Indicator Modules

Door plate indicators or directional plates.

Use the 'IN/OUT', and/or 'No Entry' inserts to create attractive door indicators.

Alternatively use the selection of arrow inserts to assemble a series of directional plates.

Pack of 3 units supplied with keyhole fixings and adhesive foam pads for wall or door fixing.

Names can be created 3 ways - see opposite page.

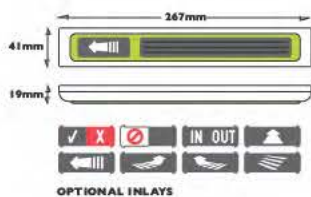

Pack of 3

Size H 41mm
W 267mm
D 19mm

Code **SPDP200**
£25.50

ShowPoint® Door and Desk Modules

These signage modules can be used for information and naming purposes.

Door or desk name plates - all in one box.

Simply add a name and mount to a door or the desk stand supplied.

Pack of 3 units supplied with 2 keyhole fixing and adhesive foam pads for wall fixing plus 3 aluminium stands for conversion to desk plates.

Names can be created 3 ways - see opposite page.

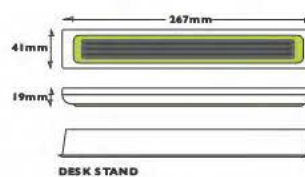

Pack of 3

Size H 41mm
W 267mm
D 19mm

Code **SPDD300**
£27.16



SHOWPOINT





ShowPoint® Sign Frame Signage System

Economical and contemporary DIY sign system.

Create signs in-house and print on any A4 or A3 printer via your PC or Mac; saving on expensive outsourced print services.

A choice of five sizes to take A6, A5, A4, A3, & 1/2A4 inserts.

All signs can be mounted portrait or landscape and can be personalised with a choice of brightly coloured decor strips.

For corridor applications there is a double sided flag sign supplied complete with heavy duty mounting bracket.

All fixings provided.



Flag display

This 1/2A4 size double sided unit protrudes at right angles to the wall, therefore ideal for identifying rooms in corridors.



SHOWPOINT

					
Size A6 H 148mm W 105mm	Size A5 H 210mm W 148mm	Size 1/2A4 H 297mm W 105mm	Size A4 H 297mm W 210mm	Size A3 H 297mm W 420mm	Flag H 105mm W 297mm
External H 164mm W 119mm	External H 226mm W 162mm	External H 313mm W 119mm	External H 313mm W 224mm	External H 313mm W 434mm	External H 119mm W 313mm
Code SFA6 £9.75	Code SFA5 £14.75	Code SFHA4 £19.00	Code SFA4 £21.67	Code SFA3 £27.83	Code SFF297 £34.16



QuickSign Snap Frame Signage System



Low cost signage solution to take 'A' sized inserts.

Economical sign holders that operate like a snap poster frame.

Easy to mount and simple to use, QuickSign is available in 5 convenient sizes all being derivatives of A4.

Enables you to create your own signage in-house on any standard A4 printer.

QuickSign can be mounted on curved walls or circular columns, due to the flexible backing plate.

These popular signs can be mounted in portrait or landscape orientation.

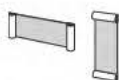

Size 1/2A5 H 77mm
W 239mm
Insert size 74 x 210mm
4 from A4 sheet
Code **BS5000**
£14.57



Size A5 H 151mm
W 239mm
Insert size 148 x 210mm
2 from A4 sheet
Code **BS5001**
£14.84



Size 1/2A4 H 108mm
W 326mm
Insert size 105 x 297mm
2 from A4 sheet
Code **BS5002**
£13.53



Size A4 H 213mm
W 326mm
Insert size 210 x 297mm
1 from A4 sheet
Code **BS5003**
£16.94

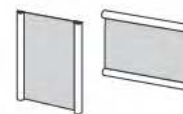

Size A4 H 300mm
W 239mm
Insert size 297 x 210mm
1 from A4 sheet
Code **BS5004**
£17.24

ShowPoint® Wall Sign System



A stylish curved wall signage system to take printed paper sign inserts.

This versatile signage system features an attractive aluminium curved profile with contrasting end caps.

Available in a range of 28 size variants. 4 depths 68mm, 90mm, 120mm and 162mm, to suit the amount and/or size of lettering to be displayed.

The printed inserts are easy to install and change with the special suction tool provided.

Each sign insert lays flat against its protective clear cover due to the curvature of the design.

Each unit is easily mounted by use of their self adhesive backing strips.



SHOW•POINT

ShowPoint® 68mm high

68mm high signs in a range of 8 different lengths from 106 to 456mm.

Please refer to each diagram for the dimension and size of printed insert.



		
Size H 68mm W 106mm Insert size 52 x 100mm Code 52100 £11.21	Size H 68mm W 156mm Insert size 52 x 150mm Code 52150 £12.17	Size H 68mm W 206mm Insert size 52 x 200mm Code 52200 £13.05
		
Size H 68mm W 256mm Insert size 52 x 250mm Code 52250 £14.11	Size H 68mm W 306mm Insert size 52 x 300mm Code 52300 £15.09	Size H 68mm W 356mm Insert size 52 x 350mm Code 52350 £16.05
		
Size H 68mm W 406mm Insert size 52 x 400mm Code 52400 £16.86	Size H 68mm W 456mm Insert size 52 x 450mm Code 52450 £17.85	

Guide to producing the Showpoint® wall sign inserts

1. Create a document to the size of the 'Insert' required.
2. Type your information into the document starting with the longest line of text.
3. Ensure that this fits comfortably within the document size.
4. Repeat with the same size text for all the other inserts to achieve a consistent look.
5. To print, ensure the correct printer has been chosen.
 Inserts up to 297mm wide should fit on an A4 printer.
 Inserts up to 420mm wide should fit on an A3 printer.
 Inserts over these widths will require printing on a large format printer.

ShowPoint® 90mm high

90mm high signs in a range of 8 different lengths from 156 to 506mm.

Please refer to each diagram for the dimension and size of printed insert.



Size H 90mm
W 156mm
Insert size 74 x 150mm
Code **74150**
£12.48



Size H 90mm
W 206mm
Insert size 74 x 200mm
Code **74200**
£13.51



Size H 90mm
W 256mm
Insert size 74 x 250mm
Code **74250**
£14.53



Size H 90mm
W 306mm
Insert size 74 x 300mm
Code **74300**
£15.59



Size H 90mm
W 356mm
Insert size 74 x 350mm
Code **74350**
£16.54



Size H 90mm
W 406mm
Insert size 74 x 400mm
Code **74400**
£17.63



Size H 90mm
W 456mm
Insert size 74 x 450mm
Code **74450**
£18.69



Size H 90mm
W 506mm
Insert size 74 x 500mm
Code **74500**
£19.79

ShowPoint® 120mm high

120mm high signs in a range of 6 different lengths from 256 to 606mm.

Please refer to each diagram for the dimension and size of printed insert.



Size H 120mm
W 256mm
Insert size 105 x 250mm
Code **105250**
£15.98



Size H 120mm
W 306mm
Insert size 105 x 300mm
Code **105300**
£17.28



Size H 120mm
W 356mm
Insert size 105 x 350mm
Code **105350**
£18.37



Size H 120mm
W 406mm
Insert size 105 x 400mm
Code **105400**
£19.64



Size H 120mm
W 506mm
Insert size 105 x 500mm
Code **105500**
£21.76



Size H 120mm
W 606mm
Insert size 105 x 600mm
Code **105600**
£24.09

ShowPoint® 162mm high

162mm high signs in a range of 6 different lengths from 306 to 656mm.

Please refer to each diagram for the dimension and size of printed insert.



Size H 162mm
W 306mm
Insert size 148 x 300mm
Code **148300**
£19.01



Size H 162mm
W 356mm
Insert size 148 x 350mm
Code **148350**
£20.38



Size H 162mm
W 406mm
Insert size 148 x 400mm
Code **148400**
£21.94



Size H 162mm
W 506mm
Insert size 148 x 500mm
Code **148500**
£24.51



Size H 162mm
W 606mm
Insert size 148 x 600mm
Code **148600**
£27.16



Size H 162mm
W 656mm
Insert size 148 x 650mm
Code **148650**
£28.36

Panorama Wall Mounted Literature Dispensers



Ever popular colourful leaflet dispensers - now with even more colour choice.

Available in 6 sizes to suit a variety of leaflet sizes and capacities.

Overlapping clear leaflet holders are housed in a curved colourful moulded body that mounts directly to the wall with concealed fixings.

Each unit is the same height so can be mounted side by side.

Choice of 10 colours including 3 new vibrant colours - Orange, Lime and Lilac.



- | | | | |
|---------------------|-------------------|--------------------|---------------------|
| WH
WHITE | GY
GREY | BK
BLACK | |
| BL
BLUE | RD
RED | GR
GREEN | YW
YELLOW |
| OR
ORANGE | LM
LIME | LC
LILAC | |



Capacity 3 x A4
Size H 521mm
W 267mm
Code **LD1000/****
£48.50



Capacity 6 x A4
Size H 521mm
W 502mm
Code **LD1001/****
£69.09



Capacity 4 x A5
Size H 521mm
W 184mm
Code **LD1002/****
£45.35



Capacity 8 x A5
Size H 521mm
W 352mm
Code **LD1016/****
£67.89



Capacity 4 x 1/3 A4
Size H 521mm
W 134mm
Code **LD1003/****
£50.08



Capacity 8 x 1/3 A4
Size H 521mm
W 255mm
Code **LD1017/****
£64.84

** Please add code of colour required



Vibrant 4 Sided Revolving Dispensers

3 new vibrant colours for these popular carousel dispensers with clear acrylic pockets.

The 30mm capacity pockets do not overlap, showing the full front cover of the brochure.

Can accommodate A4, A5 and 1/3A4 sized documents in 12, 16 or 32 pockets.

3 colours; Orange, Lime or Lilac on a chrome central column with grey star base.

Vibrant colour options



ORANGE LIME LILAC



Capacity 12 x A4
 Size H 1690mm
 W 560mm
 D 560mm
 Code **LD2500/****
£473.99



Capacity 16 x A5
 Size H 1690mm
 W 560mm
 D 560mm
 Code **LD2600/****
£516.54



Capacity 32 x 1/3A4
 Size H 1690mm
 W 560mm
 D 560mm
 Code **LD2700/****
£498.55



** Please add code of colour required

Traditional 4 Sided Revolving Dispensers

Revolving leaflet dispenser with clear acrylic pockets mounted onto a 4 sided central carousel.

The 30mm capacity pockets do not overlap, showing the full front cover of the brochure/leaflet.

Can accommodate A4, A5 and 1/3A4 sized documents in 12, 16 or 32 pockets.

Available in Blue, Red, White and Grey with grey star base and chrome central column.



Capacity 12 x A4
 Size H 1690mm
 W 560mm
 D 560mm
 Code **LD2000/****
£434.67



Capacity 16 x A5
 Size H 1690mm
 W 560mm
 D 560mm
 Code **LD2001/****
£428.72



Capacity 32 x 1/3A4
 Size H 1690mm
 W 560mm
 D 560mm
 Code **LD2002/****
£449.62

Traditional colour options



GREY BLUE RED WHITE



** Please add code of colour required

Pirouette Literature Dispenser

Modular leaflet dispenser – tailored to your needs.

Create your own combination by selecting the three tiers of your choice together with a pole and base unit.

Each tier has eight individual pockets to accommodate A4, A5 or 1/3A4 documents.

Each tier rotates individually and can be replaced at any time, to match your current requirement.



Pole
Size H 1560mm
W 560mm
D 560mm
Code **LD2010**
£116.68



Tier (1 of 3)
Capacity 8 x A4
Code **LD2011**
£126.23



Tier (1 of 3)
Capacity 8 x A5
Code **LD2012**
£88.31



Tier (1 of 3)
Capacity 8 x 1/3A4
Code **LD2013**
£72.05



A4 Brochure Stands

Freestanding A4 brochure display.

Present your brochure at the right height and angle in a clear deep pocket.

The 70mm acrylic holder is mounted on a satin anodised aluminium column mounted on a stable base.

Available in both landscape and portrait A4 formats.



Capacity A4 Portrait
Size H 1000mm
W 250mm
D 330mm
Code **LD1077**
£88.09



Capacity A4 Landscape
Size H 970mm
W 250mm
D 330mm
Code **LD1076**
£86.88

Single Pocket Literature Dispenser

Single pocket leaflet dispensers ideal for mounting on loop nylon display systems (see pages 126 - 142) or to a wall.

These leaflet dispensers have a large capacity A4, A5 or 1/3A4 pocket.

The all clear acrylic design allows the whole of the literature cover to be viewed.

Mount using the BusyFix® coins provided or screw fix to a suitable wall.



Capacity A4
Code **LD1005**
£16.69



Capacity A5
Code **LD1006**
£16.50



Capacity 1/3A4
Code **LD1007**
£13.03



All Clear Literature Dispensers

The clear choice for a clear view.

Clever yet simple concept of a totally clear leaflet dispenser with holders that do not overlap, allowing the full front of every brochure to be displayed.

The entire product is manufactured from clear moulded acrylic, therefore the surrounding decor is also not compromised.

Wide range of sizes and configurations are available including mixed format units.

6 sizes can be mounted on a freestanding frame.

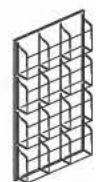

Capacity 12 x A4

Size H 1245mm
W 762mm

Wall Mounted **G10111**
£265.15

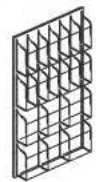

Capacity 12 x 1/3 A4 + 6 x A4

Size H 1143mm
W 762mm

Wall Mounted **G10110**
£259.27

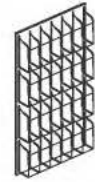

Capacity 24 x 1/3 A4

Size H 1041mm
W 762mm

Wall Mounted **G10109**
£252.53



Capacity 9 x A4

Size H 934mm
W 762mm

Wall Mounted **G10101**
£240.19

Freestanding **G10101S**
£355.77



Capacity 6 x 1/3 A4 + 6 x A4

Size H 883mm
W 762mm

Wall Mounted **G10107**
£228.12

Freestanding **G10107S**
£343.71



Capacity 6 x A4

Size H 626mm
W 762mm

Wall Mounted **G10103**
£183.84

Freestanding **G10103S**
£299.42



Capacity 6 x 1/3 A4 + 3 x A4

Size H 572mm
W 762mm

Wall Mounted **G10106**
£177.17

Freestanding **G10106S**
£292.76



Capacity 12 x 1/3 A4

Size H 521mm
W 762mm

Wall Mounted **G10112**
£163.52

Freestanding **G10112S**
£279.11



Capacity 12 x A5

Size H 762mm
W 762mm

Wall Mounted **G10127**
£204.63

Freestanding **G10127S**
£320.22

All Clear Premier Literature Displays



Wall Mounted

Attractive clear wall displays.

Contemporary acrylic design for wall mounting in multiples of 5 pockets.

Mount units side by side for larger displays of A4 literature.

Holds 32mm of literature in each pocket.

Also available as desktop and revolving floor stands to match.



Capacity 5 x A4
 Size H 578mm
 W 241mm
 D 150mm
 Code **6103102**
£51.89

Revolving Floor Stand

Premier clear display units for maximum impact.

Three sided carousel unit with 30 pocket capacity.

Each A4 pocket is 32mm deep and is moulded in clear polystyrol.

The carousel rotates on a central column which is mounted on a mobile base.

Capacity 30 x A4
 Size H 1720mm
 W 440mm
 D 440mm
 Code **6255802**
£478.90



Desktop Unit

Attractive clear 3 pocket desk displays.

Contemporary acrylic design.

Stand units side by side for larger displays of A4 literature.

Holds 32mm of literature in each pocket.

Also available are wall mounted and revolving floor stands to match.

Capacity 3 x A4
 Size H 330mm
 W 240mm
 D 300mm
 Code **6102702**
£46.14



Crest Literature Dispensers

Wall Mounted Dispensers



Contemporary leaflet dispenser.

The simple clear leaflet holders are complimented with modern satin anodised supports.

Dividers are supplied to enable each pocket to be converted from A4 to accept 1/3 A4 sized leaflets.

The 9 x A4 can also be converted to accept up to 18 x 1/3 A4, and the 3 x A4 can be converted to take up to 6 x 1/3 A4.

Supplied with wall fixings.

Some configuration options by using dividers provided

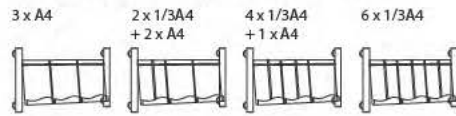

Capacity 3 x A4 or
6 x 1/3 A4
Size H 387mm
W 806mm
D 127mm
Code **G4133SL**
£89.16

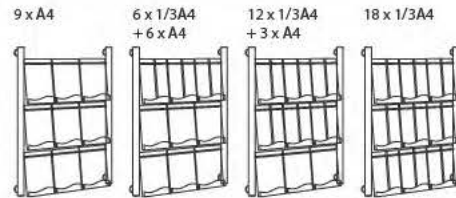

Capacity 9 x A4 or
18 x 1/3 A4
Size H 1041mm
W 806mm
D 127mm
Code **G4134SL**
£214.56



Freestanding Dispenser

A sleek and elegant freestanding leaflet display.

The simple clear leaflet holders are complimented with modern satin anodised frame.

Dividers are supplied to enable each pocket to be converted from A4 to accept 1/3 A4 sized leaflets.

Adjustable button feet to aid stability.

Some configuration options by using dividers provided

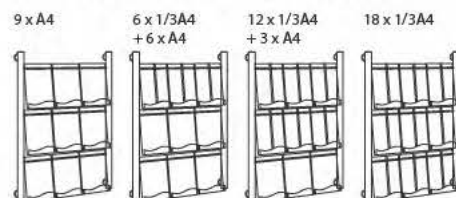

Capacity 9 x A4 or
18 x 1/3 A4
Size H 1594mm
W 806mm
D 508mm
Code **G4135SL**
£317.53

3 Tier Expandable Desktop Dispensers



Clear, compact and low cost.

Three tier unit available in A4, A5 and 1/3 A4 formats, moulded in crystal clear styrene.

All units can be joined together with optional clips.



Capacity 3 x 1/3A4
Size H 230mm
W 112mm
D 116mm
Code **LD3006**
£17.48



Capacity 3 x A5
Size H 230mm
W 160mm
D 116mm
Code **LD3014**
£18.06



Capacity 3 x A4
Size H 330mm
W 228mm
D 116mm
Code **LD3005**
£30.33

Joining Clips
Packet of 10
Code **LD3013**
£2.67

Revolving Desktop Literature Dispensers



Revolving clear acrylic pockets to maximise visibility.

White top and base hold 4 pockets which are available in 3 formats A4, A5 and 1/3A4. 30mm deep capacity in each pocket.

The all clear acrylic pocket design allows the whole of the literature cover to be viewed.

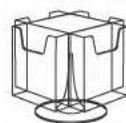

Capacity 4 x A4
Size H 250mm
W 305mm
D 305mm
Code **LD3000**
£104.70



Capacity 4 x A5
Size H 180mm
W 245mm
D 245mm
Code **LD3001**
£72.00



Capacity 4 x 1/3A4
Size H 180mm
W 200mm
D 200mm
Code **LD3002**
£65.01



New Acrylic Front Literature Dispensers

Contemporary design features deep blue acrylic front which contrasts with the high white MDF body.

Shelf unit takes up to 5 A4 items side by side.

Wall unit in 2 capacity options, 6 or 12 pockets.

Matching Stacking Dispensers are available which hold 700mm of A4 literature in 1 or 3 columns.



Shelf Dispensers



Capacity 5 x A4
 Size H 222mm
 W 1314mm
 D 92mm
 Code **LDM2000/WB**
£135.31



Wall Mounted Dispensers



Capacity	6 x A4	Size	Takes	12 x A4
	H 944mm		Size	H 944mm
	W 286mm			W 554mm
	D 100mm			D 100mm
Code	LDC1006/WB	Code	LDC1012/WB	
	£167.88		£262.95	

Stacking Dispensers



Takes	1 x A4	Takes	3 x A4
Capacity	700mm	Capacity	700mm
Size	H 1002mm	Size	H 1002mm
	W 256mm		W 732mm
	D 345mm		D 345mm
Code	LDS1001/WB	Code	LDS1003/WB
	£218.27		£331.38



Shelf Style Wall Mounted Literature Display



Simple sleek and modern design, sold as a single unit or as a pack of 3.

Can be mounted one above the other or side by side in multiples.

The full height 6mm acrylic fascia panel allows the entire artwork to be seen clearly.

Suitable for literature up to A4.

No dividers, allowing a fully flexible open space for storing magazines, brochures, books, etc.

Depth of 58mm allowing multiple items to be stored one in front of the other.

Supplied ready assembled.

Available in a choice of beech, black, white or blue finish.



Capacity 58mm
 Size H 222mm
 W 1314mm
 D 92mm

Single		Pack of 3	
Beech	LDM1000/BH £124.04	Beech	LDM1000PK/BH £340.58
Blue	LDM1000/BL £128.32	Blue	LDM1000PK/BL £352.58
White	LDM1000/WH £128.32	White	LDM1000PK/WH £352.58
Black	LDM1000/BK £128.32	Black	LDM1000PK/BK £352.58

Cinco Literature Stands

2 mobile brochure stands with a functional yet contemporary design.

Steel frame with angled plastic shelves. Shelves hold up to 35mm of material.

The larger unit can house a variety of different sized materials on 700mm wide shelves.

Both units are ideal for use in reception areas.

Locking castors.

Easy self assembly.



Capacity 15 x A4
Size H 1660mm
W 820mm
D 510mm
Code **LD4004**
£314.35



Capacity 5 x A4
Size H 1660mm
W 340mm
D 510mm
Code **LD4003**
£231.81



Quatro Premier Literature Stands

Premier leaflet display with a choice of adjustable steel or transparent acrylic shelves.

The attractive new design enables the shelves to be independently set at 15°, 45° or 90° during assembly; to suit your presentation requirements.

Available in 4 x A4 or 12 x A4 models.

As there are no dividers or separators the shelves can accommodate virtually any style of literature.

Satin anodised aluminium framework.

Supplied with 4 castors for mobility.



Transparent Acrylic Shelf Stands



Capacity 12 x A4
Size H 1760mm
W 940mm
D 425mm
Code **A6813402**
£404.63



Capacity 4 x A4
Size H 1760mm
W 370mm
D 425mm
Code **A6813302**
£322.66

Steel Shelf Stands



Capacity 12 x A4
Size H 1760mm
W 940mm
D 425mm
Code **S6813499**
£264.10



Capacity 4 x A4
Size H 1760mm
W 370mm
D 425mm
Code **S6813399**
£217.22



Wave Freestanding Literature Dispensers

Eye-catching leaflet dispenser.

Stylish leaflet dispenser with four oversized A4 shelves, mounted on a sturdy steel frame.

Finished in a choice of three powder coat colours – White, Grey and Black.

Header panel at the top can take vinyl stickers/ letters for personalisation.

Supplied with a set of four optional castors for mobility.

Simple self assembly.

Capacity	4 x A4		
Size	H 1430mm		
	W 350mm		
	D 310mm		
Grey	LDF8GS	£88.31	
White	LDF8W	£88.31	
Black	LDF8B	£88.31	

Wave Wider Freestanding Literature Dispensers

Introducing a wider version of the popular Wave Literature Dispenser.

Same contemporary design as the original Wave Literature Dispenser, the wider unit allows for 2 A4 pieces of literature to be displayed side by side.

Finished in a choice of three powder coat colours – White, Grey and Black.

Header panel at the top can take vinyl stickers/ letters for personalisation.

Simple self assembly.

Capacity	8 x A4		
Size	H 1430mm		
	W 500mm		
	D 310mm		
Grey	LDF16GS	£107.56	
White	LDF16W	£107.56	
Black	LDF16B	£107.56	



Mesh Literature Dispensers

Mesh Wall Mounted Literature Dispensers

Smart wire mesh brochure dispenser.
 Wall mounted brochure dispenser available with 5 or 10 large capacity A4 pockets, finished in black powder coated wire mesh.
 The overlapping tiered pockets present almost half of the front cover of each leaflet.
 Easy wall mounting, fixings supplied.



Capacity 5 x A4
 Size H 720mm
 W 260mm
 D 90mm
 Code **G5578BL**
£78.46

Capacity 10 x A4
 Size H 1290mm
 W 260mm
 D 90mm
 Code **G5579BL**
£118.83



Mesh Freestanding Literature Dispensers

High capacity rotational dispenser.
 Three sided leaflet display finished in classic black powder coat.
 The carousel has 30 A4 overlapping pockets and rotates 360° as a single unit.
 Each pocket is 25mm deep giving this unit a considerable capacity.

Capacity 30 x A4
 Size H 1680mm
 W 420mm
 D 420mm
 Code **G5577BL**
£398.50





Mesh Desktop Literature Dispensers

Space saving leaflet dispenser in three convenient sizes.

The A4 variants come with dividers to convert them to 1/3A4.

Finished in black powder coated wire mesh.



Capacity 4 x 1/3A4
Size H 419mm
W 133mm
D 178mm
Code **G5641BL**
£49.79



Capacity 4 x A4 or
8 x 1/3A4
Size H 457mm
W 248mm
D 165mm
Code **G5640BL**
£75.13



Capacity 1 x A4 or
2 x 1/3A4
Size H 222mm
W 248mm
D 127mm
Code **G5643BL**
£14.95

Mesh Document Racks

These wall or partition document organiser racks are designed to take literature up to 310mm wide.

Both of the 1 or 3 pocket models have large 45mm capacity pockets which are finished in black powder coated wire mesh.

The subtle yet sturdy coated steel rack holds each pocket at the optimum visual angle.

Additional hanging brackets are included for fitting over a partition screen.



1 pocket rack
Capacity 1 x 310mm
wide pockets
Size H 248mm
W 337mm
D 102mm
Code **G6455BL**
£41.46



3 pocket rack
Capacity 3 x 310mm
wide pockets
Size H 457mm
W 337mm
D 102mm
Code **G6452BL**
£73.56



Mesh Floor Racks

These floor racks are designed to take literature up to 310mm wide.

Both of the 3 or 5 pocket models have large 45mm capacity pockets which are finished in black powder coated wire mesh.

The subtle yet sturdy coated steel stand holds each pocket at the optimum visual angle.

Folds flat for portability and storage.



3 pocket floor rack
Capacity 3 x 310mm
wide pockets
Size H 680mm
W 318mm
D 330mm
Code **G6460BL**
£73.92



5 pocket floor rack
Capacity 5 x 310mm
wide pockets
Size H 1168mm
W 318mm
D 470mm
Code **G6461BL**
£108.04



Steel Revolving Literature Dispensers

4 sided revolving floor stand in black coated steel. This sturdy design allows for a large amount of A4 literature to be displayed in either 44 or 92 separate compartments. Holds 20mm of literature in each. The unit rotates through 360° to allow for easy access to all sides. Ideal for displaying brochures, magazines or works orders.



Capacity 44 x A4
 Size H 1219mm
 W 356mm
 D 356mm
 Code **G4324BL**
£552.51

Capacity 92 x A4
 Size H 1727mm
 W 356mm
 D 356mm
 Code **G4325BL**
£736.48

Steel Wall Mounted Literature Dispensers

Sturdy wall mounted or freestanding display racks in black coated steel.

This contemporary design allows the wall mounting of A4 literature in multiples of 5, 11 or 23 separate compartments.

Mount either unit side by side for larger displays.

Add the feet option to convert any unit to be freestanding.

Each compartment holds 20mm of literature.

Also available as revolving floor stands to match.

Suitable for displaying brochures, magazines or within the manufacturing environment for works orders etc.



Capacity 5 x A4
Size H 521mm
W 254mm
D 102mm

Code **G4310BL**
£77.88



Capacity 11 x A4
Size H 921mm
W 254mm
D 102mm

Code **G4321BL**
£107.75



Capacity 23 x A4
Size H 1664mm
W 254mm
D 102mm

Code **G4322BL**
£189.92



Feet
Size H 133mm
Footprint W 258mm
D 356mm

Code **G4323BL**
£34.88



Steel 7 Pocket Wall Mounted Rack

Contemporary black coated steel rack that mounts to the wall.

Holds 30mm of literature in each pocket.

Simple wall fixings included.

With open sides they are ideal for holding larger pieces of literature such as newspapers and magazines.

Capacity 30mm
Size H 552mm
W 241mm
D 50mm

Code **G3185BL**
£58.73



Wire Literature Dispensers

Wall Mounted Literature Dispenser

Sturdy coated wire steel displays capable of retaining 55mm of literature in each holder.

This range includes models that have 3, 5 or 7 holders for A4 literature.

Finished in black powder coat and simply mounted by 2 keyhole fixing brackets.



Capacity 3 x A4
Size H 495mm
W 235mm
D 165mm
Code **G6430BL**
£33.44



Capacity 5 x A4
Size H 737mm
W 235mm
D 165mm
Code **G6431BL**
£44.99



Capacity 7 x A4
Size H 978mm
W 235mm
D 165mm
Code **G6432BL**
£55.75



Desktop Literature Dispenser

Economical way to display literature on your desktop.

Sturdy coated wire steel displays capable of retaining up to 55mm of A4 literature in each of the 5 holders.

The holders and stand are finished in black powder coating.



Capacity 5 x A4
Size H 432mm
W 248mm
D 229mm
Code **G6433BL**
£43.97

Revolving Literature Dispensers

Rotary leaflet and brochure display.

Four rotational tiers are mounted on a central column with each tier being able to rotate independently.

The simple wire construction means that the full front of every leaflet/brochure is on full view.

The leaflet model has 32 pockets to accommodate 1/3 A4 items and the brochure model has 16 x A4 pockets.

Finished in black powder coat and mounted on five castors two of which are locking.



Capacity 32 x 1/3 A4
 Size H 1524mm
 W 381mm
 D 381mm
 Code **G4128CH**
£221.45



Capacity 16 x A4
 Size H 1524mm
 W 381mm
 D 381mm
 Code **G4139CH**
£199.42



Mobile Magazine Rack

Five large shelves, an ideal way to display all types of brochures, magazines, catalogues and newspapers.

Finished in black powder coated wire, with tubular side frames.

Mounted on four castors for mobility.



Capacity 15 x A4
 Size H 1613mm
 W 825mm
 D 387mm
 Code **G4129CH**
£196.27

Oak Deluxe Wall Mounted Literature Dispensers

Traditional solid wood leaflet dispenser.
 Wall mounted leaflet dispenser framed in oak finish solid wood.
 Clear acrylic pocket front allowing the full front of every brochure to be displayed.
 This ensures the full front of the displayed information is on clear view.
 A wide range of sizes and configurations are available, including mixed format units.
 Wall fixings included.

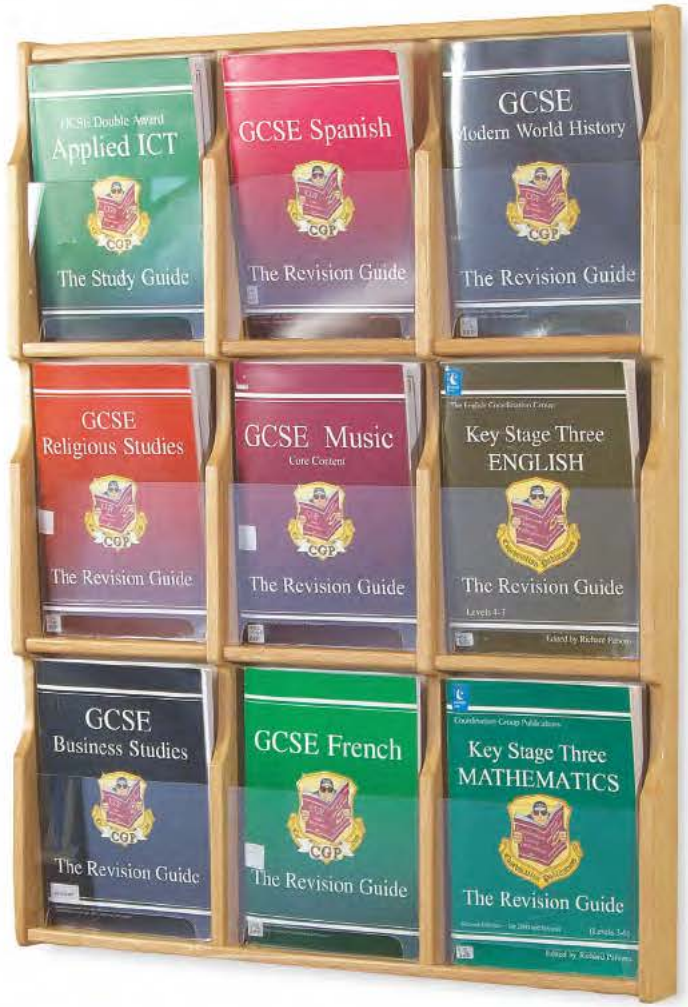

Capacity 9 x A4
 Size H 972mm
 W 756mm
 Code **G48101**
£251.38

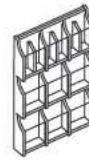

Capacity 6 x 1/3 A4
 + 6 x A4
 Size H 972mm
 W 756mm
 Code **G48107**
£251.38

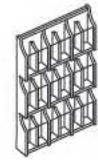

Capacity 18 x 1/3 A4
 Size H 972mm
 W 756mm
 Code **G48102**
£251.38



Capacity 6 x A4
 Size H 667mm
 W 756mm
 Code **G48103**
£193.83



Capacity 6 x 1/3 A4
 + 3 x A4
 Size H 667mm
 W 756mm
 Code **G48106**
£193.83



Capacity 12 x 1/3 A4
 Size H 667mm
 W 756mm
 Code **G48112**
£193.83



Capacity 4 x A4
 Size H 667mm
 W 508mm
 Code **G48104**
£155.88



Capacity 8 x 1/3 A4
 Size H 667mm
 W 508mm
 Code **G48105**
£155.88

Wooden Wall Literature Dispensers

Elegant wall mounted display racks with durable Oak or Mahogany wood finish.

This traditional design allows the wall mounting of A4 literature in multiples of 5 or 12 separate compartments.

Mount either unit side by side for larger displays.

Each attractive scoop front compartment holds 20mm of literature.

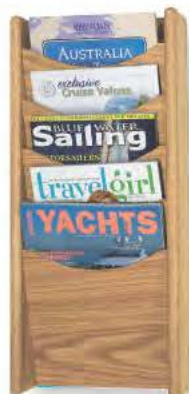

Capacity 5 x A4
Size H 603mm
W 286mm
D 95mm
Oak **G4330MO**
Mahogany **G4330MH**

£95.89
£95.89



Capacity 12 x A4
Size H 1238mm
W 286mm
D 95mm
Oak **G4331MO**
Mahogany **G4331MH**

£174.38
£174.38

Wooden Revolving Literature Dispensers

4 sided revolving floor stand in Oak or Mahogany wood finish.

This sturdy design allows for a large amount of A4 literature to be displayed in 48 separate scoop fronted compartments.

Holds 20mm of literature in each.

The unit rotates through 360° to allow for easy access to all sides.



Capacity 48 x A4
Size H 1257mm
W 451mm
D 451mm
Oak **G4335MO**
Mahogany **G4335MH**

£947.58
£947.58





BusyFold® Heavy Duty Tabletop Displays

FREE Storage bag with carrying handles and shoulder strap is included with each BusyFold® unit.



Aluminium framed display system for extra durability.

Robust aluminium framed panels with interlocking gear hinge mechanism creates a very professional display system.

The double sided panels are available in a choice of 14 loop nylon finishes, 4 supplied from stock.

Supplied with header panel which has loop nylon fabric on one side and black on reverse for optional personalising.

Storage bag with carrying handles and shoulder strap is included.

For BusyFix®, spot lights and other accessories - see page 131.

Dimensions H x W

Portrait	
All 3 panels	1000 x 700mm
Header panel	200 x 700mm
Landscape	
Centre panel	685 x 1010 mm
Side panels	685 x 505 mm
Header panel	190 x 1010 mm



Portrait
 Size H 1200mm
 W 2100mm
 Code **59264/****
£170.42

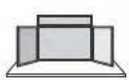

Landscape
 Size H 900mm
 W 2000mm
 Code **59263/****
£152.92

** Please add code of colour required

Loop nylon cloth - Stock colours

RB	AR	EG	TW
ROYAL BLUE	ALFA RED	EMERALD GREEN	TWIN COLOUR BLUE/GREY

Non-stock colours - made to order - Please allow an extra 2-3 days

LB	YL	BU	BK	PU	MG	LC	OR	CY	AG
LIGHT BLUE	YELLOW	BURGUNDY	BLACK	PURPLE	MAGENTA	LILAC	ORANGE	CYAN	APPLE

BusyFold® Light Tabletop Displays

Lightweight tabletop folding display systems are ideal for small presentations and displays, course work or exhibitions.

Double sided panels fold down to 900 x 600mm or 1000 x 700mm for XL version.

Panels accept Velcro®, BusyFix® (see accessories on page 131) or pins.

Supplied with header panel which has loop nylon fabric on one side and black on reverse for optional personalising.

14 Loop nylon colour options.

Black or grey frame options.



Landscape

Dimensions - H x W	Standard	XL
Centre panel	600 x 900mm	700 x 1000mm
Side panels	600 x 450mm	700 x 500mm
Header panel	200 x 900mm	200 x 1000mm

Standard		XL	
Size	H 800mm W 1800mm	Size	H 900mm W 2000mm
Weight	3kg	Weight	3.9kg
Black frame	BFTLB/** £92.77	Black frame	BFXTLB/** £126.81
Grey frame	BFTLG/** £92.77	Grey frame	BFXTLG/** £126.81



** Please add code of colour required

Portrait

Dimensions - H x W	Standard	XL
Centre panel	900 x 600mm	1000 x 700mm
Header panels	200 x 600mm	200 x 700mm

Standard		XL	
Size	H 1100mm W 1800mm	Size	H 1200mm W 2100mm
Weight	4kg	Weight	5.2kg
Black frame	BFTPB/** £105.78	Black frame	BFXTPB/** £144.65
Grey frame	BFTPG/** £105.78	Grey frame	BFXTPG/** £144.65

** Please add code of colour required



FREE Storage bag with carrying handles and shoulder strap is included with each BusyFold® unit.



Loop nylon cloth - Stock colours



Non-stock colours - made to order - Please allow an extra 2-3 days





Folding Exhibition and Display Systems



Double sided folding display systems with plastic or aluminium frames.

Both systems include carrying bags for transportation/storage.

All systems are made in the UK.

Loop nylon covering to accept pins or Velcro® fasteners.

Header panels are coloured alike one side, Black on reverse.

Both ranges offer the same 14 loop nylon colour options.

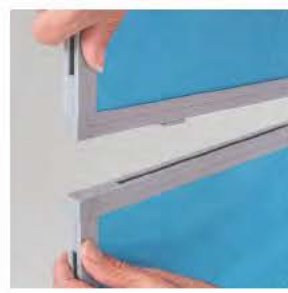

BUSYFOLD LIGHT
PLASTIC FRAME



BUSYFOLD HEAVY DUTY
ALUMINIUM FRAME

- Loop nylon cloth - Stock colours**
- RB ROYAL BLUE
 - AR ALFA RED
 - EG EMERALD GREEN
 - TW TWIN COLOUR BLUE/GREY

- Non-stock colours - made to order - Please allow an extra 2-3 days**
- LB LIGHT BLUE
 - YL YELLOW
 - BU BURGUNDY
 - BK BLACK
 - PU PURPLE
 - MG MAGENTA
 - LC LILAC
 - OR ORANGE
 - CY CYAN
 - AG APPLE

FREE Storage bag with carrying handles and shoulder strap is included with each BusyFold® unit.

BusyFold® Light Kit with Plastic Frame

Panel size 600 x 900mm, header 600 x 200mm.
Standard Black or premium Grey frames.
Panels have sturdy plastic hinges.
2 halves and header panels snap together.
14 loop nylon colours - see opposite page.

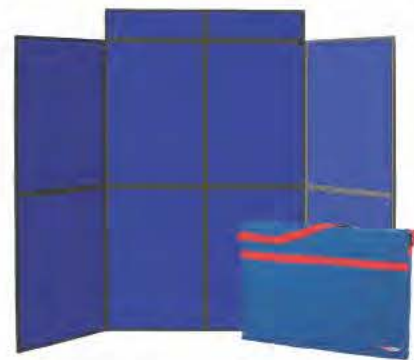

6 Panel + header

Size H 2000mm
W 1800mm

Weight 8.5kg

Black frame **BL6KB/****
£185.58

Grey frame **BL6KG/****
£185.58

7 Panel + header

Size H 2000mm
W 1800mm

Weight 13.7kg

Black frame **BL7KB/****
£230.25

Grey frame **BL7KG/****
£230.25

8 Panel + 2 headers

Size H 2000mm
W 2400mm

Weight 11kg

Black frame **BL8KB/****
£262.25

Grey frame **BL8KG/****
£262.25

10 Panel + 2 headers

Size H 2000mm
W 2400mm

Weight 24kg

Black frame **BL10KB/****
£352.85

Grey frame **BL10KG/****
£352.85

** Please add code of colour required

BusyFold® Light XL Kit with Plastic Frame

Panel size 700 x 1000mm, header 700 x 200mm.
Panels have sturdy plastic hinges.
2 halves and header panels snap together.
14 loop nylon colours - see page 131.



6 Panel + header

Size H 2200mm
W 2100mm

Weight 10.5kg

Black frame **BLX6KB/****
£226.86

Grey frame **BLX6KG/****
£226.86

7 Panel + header

Size H 2200mm
W 2100mm

Weight 17.5kg

Black frame **BLX7KB/****
£275.94

Grey frame **BLX7KG/****
£275.94

8 Panel + 2 headers

Size H 2200mm
W 2800mm

Weight 14kg

Black frame **BLX8KB/****
£296.49

Grey frame **BLX8KG/****
£296.49

10 Panel + 2 headers

Size H 2200mm
W 2800mm

Weight 27kg

Black frame **BLX10KB/****
£376.19

Grey frame **BLX10KG/****
£376.19

** Please add code of colour required

BusyFold® Heavy Duty Kit with Aluminium Frame

Panel size 700 x 1000mm, header 700 x 200mm.
Interlocking gear hinge mechanism.
2 halves lock together with sliders.
Matching plinths are available online.
14 loop nylon colours - see opposite page.



6 Panel + header

Size H 2200mm
W 2100mm

Weight 16kg

Code **59265K/****
£306.49

7 Panel + header

Size H 2200mm
W 2100mm

Weight Code 20kg

Code **59268K/****
£366.66

8 Panel + 2 headers

Size H 2200mm
W 2800mm

Weight 19.5kg

Code **59271K/****
£409.12

** Please add code of colour required

MORE OPTIONS ►

BusyFold® Light with Plastic Frame

Panel size 600 x 900mm.
 Standard Black or premium Grey frames.
 Panels have sturdy plastic hinges.
 2 halves and header panels snap together.
 14 loop nylon colours - see below.



6 Panel system
 Size H 1800mm
 W 1800mm
 Weight 7.5kg
 Black frame **BL6B/****
£163.82
 Grey frame **BL6G/****
£163.82



7 Panel system
 Size H 1800mm
 W 1800mm
 Weight 12.7kg
 Black frame **BL7B/****
£224.26
 Grey frame **BL7G/****
£224.26



8 Panel system
 Size H 1800mm
 W 2400mm
 Weight 9.7kg
 Black frame **BL8B/****
£223.48
 Grey frame **BL8G/****
£223.48



10 Panel system
 Size H 1800mm
 W 3000mm
 Weight 12.13kg
 Black frame **BL10B/****
£274.46
 Grey frame **BL10G/****
£274.46

Header
 Size H 200mm
 W 600mm
 Black frame **BLHB/****
£16.50
 Grey frame **BLHG/****
£16.50

** Please add code of colour required

BusyFold® Light XL with Plastic Frame

As above but with larger panel size
 700 x 1000mm.



6 Panel XL system
 Size H 2000mm
 W 2100mm
 Weight 9.5kg
 Black frame **BLX6B/****
£187.34
 Grey frame **BLX6G/****
£187.34



7 Panel XL system
 Size H 2000mm
 W 2100mm
 Weight 16.5kg
 Black frame **BLX7B/****
£236.42
 Grey frame **BLX7G/****
£236.42



8 Panel XL system
 Size H 2000mm
 W 2800mm
 Weight 12.6kg
 Black frame **BLX8B/****
£239.19
 Grey frame **BLX8G/****
£239.19



10 Panel XL system
 Size H 2000mm
 W 3500mm
 Weight 18.8kg
 Black frame **BLX10B/****
£297.16
 Grey frame **BLX10G/****
£297.16

Header
 Size H 200mm
 W 700mm
 Black frame **BLXHB/****
£16.00
 Grey frame **BLXHG/****
£16.00

** Please add code of colour required

BusyFold® Heavy Duty with Aluminium Frame

Panel size 700 x 1000mm, headers 200mm high.
 Interlocking gear hinge mechanism.
 2 halves lock together with sliders.
 Matching plinths are available - see opposite.
 14 loop nylon colours - see below.



6 Panel system
 Size H 2000mm
 W 2100mm
 Weight 15kg
 System **59265/****
£260.28
 Linked Header **59277/****
£72.88



7 Panel system
 Size H 2000mm
 W 2100mm
 Weight 19kg
 System **59268/****
£320.45
 Linked Header **59277/****
£72.88



8 Panel system
 Size H 2000mm
 W 2800mm
 Weight 18.5kg
 System **59271/****
£337.29
 Linked Header **59280/****
£93.08

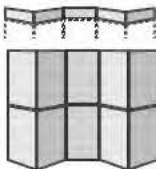

10 Panel system
 Size H 2000mm
 W 3500mm
 Weight 23kg
 System **59274/****
£413.79
 Linked Header **59283/****
£112.67

Single header
 Size H 200mm
 W 700mm
 Single Header **59286/****
£25.61

** Please add code of colour required

Loop nylon cloth - Stock colours

RB	AR	EG	TW
ROYAL BLUE	ALFA RED	EMERALD GREEN	TWIN COLOUR BLUE/GREY

Non-stock colours - made to order - Please allow an extra 2-3 days

LB	YL	BU	BK	PU	MG	LC	OR	CY	AG
LIGHT BLUE	YELLOW	BURGUNDY	BLACK	PURPLE	MAGENTA	LILAC	ORANGE	CYAN	APPLE



BusyFold® Light 1800 with Plastic Frame

Each panel is 600mm wide but is a full 1800mm high, therefore eliminating the central join.
Each panel is joined by a full length flexible hinge.
Optional header panels.
Standard Black or premium Grey frames.
14 loop nylon colours - see opposite page.



3 Panel system

Size H 1800mm
W 1800mm

Weight 7.8kg
Black **BL3KB/****
£177.55
Grey **BL3KG/****
£177.55



4 Panel system

Size H 1800mm
W 2400mm

Weight 9.7kg
Black **BL4KB/****
£227.55
Grey **BL4KG/****
£227.55



5 Panel system

Size H 1800mm
W 3000mm

Weight 12.1kg
Black **BL5KB/****
£278.66
Grey **BL5KG/****
£278.66



Header

Size H 200mm
W 600mm

Black frame **BLHB/****
£16.50
Grey frame **BLHG/****
£16.50



** Please add code of colour required

BusyFold® Heavy Duty Plinths with Aluminium Frame

Enhance the folding display system with these matching aluminium folding plinths.
Interlocking gear hinge mechanism.
The white platforms secure the folding panels.
Panels hinge open to create a useful cupboard.
14 loop nylon colours - see opposite page.



Size H 500mm
W 350mm
D 350mm

Weight 4.5kg
Code **PL5035/****
£108.08



Size H 1000mm
W 350mm
D 350mm

Weight 7.1kg
Code **PL1035/****
£148.75



Size H 500mm
W 700mm
D 700mm

Weight 9kg
Code **PL5070/****
£141.92



Size H 1000mm
W 700mm
D 700mm

Weight 12.5kg
Code **PL1070/****
£199.25

** Please add code of colour required



BusyFold® Accessories



BusyFix® coins

20mm diameter self adhesive coins.

For attaching artwork to loop nylon panels.

Pack of 100 **45120**
£7.48
Pack of 1000 **45BR**
£47.08



Bags

To fit all BusyFold® systems except 1800 and Plinths.

6 Panel system **DB1020**
£40.03
7 & 8 Panel systems **DB1021**
£39.03
10 Panel system **DB1022**
£73.64



Leaflet holder

Clear acrylic holder.

Attaches with Velcro fasteners to any loop nylon panel.

A4 **LD1005**
£16.95
A5 **LD1006**
£16.50
1/3A4 **LD1007**
£13.03



MightyBoard Display System

Ideal when you want to create a big, semi-permanent display.

Largest display panel size of up to 1800 x 1200mm mounted onto a substantial pole and base system.

The modular design enables the system to be extended at any point in time.

High impact PVC framed panels are double sided with a choice of 14 loop nylon coverings which accept pins and Velcro®.

For BusyFix®, spot lights and other accessories see page 131.



Kit F
 Panels 2 panels
 Height 1800mm
 Display H 900mm
 W 3600mm
 Or H 1800mm
 W 1800mm
 Code **MBKF/****
£447.84

** Please add code of colour required



Kit H
 Panels 3 panels
 Height 1800mm
 Display H 1200mm
 W 5400mm
 Or H 1800mm
 W 3600mm
 Code **MBKH/****
£626.08

** Please add code of colour required



Kit G
 Panels 3 panels
 Height 1800mm
 Display H 1200mm
 W 3600mm
 Code **MBKG/****
£563.33

** Please add code of colour required

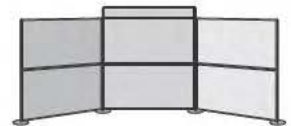

Kit I
 Panels 6 panels
 Height 2000mm (inc header)
 Display H 1800mm
 W 5400mm
 Code **MBKI/****
£1021.37

** Please add code of colour required



Loop nylon cloth





MightyBoard Exhibitor System

The MightyBoard Exhibitor is portable thanks to its split pole design and compact panel size, enabling the system to be loaded into a car.

All components are fully interchangeable with MightyBoard Display.

The panels lock firmly into position to create a very safe structure.

High impact PVC framed panels are double sided with a choice of 14 loop nylon coverings which accept pins, Velcro® and BusyFix®.

For BusyFix®, spot lights and other accessories see page 131.



Kit A	
Panels	4 panels
Headers	2 headers
Display	H 2000mm (inc header)
	W 1800mm
Code	MBKA/** £567.17

** Please add code of colour required - see opposite page



Kit B	
Panels	4 panels
Headers	2 headers
Display	H 2000mm (inc header)
	W 2400mm
Code	MBKB/** £583.86

** Please add code of colour required - see opposite page



Kit C	
Panels	6 panels
Headers	3 headers
Display	H 2000mm (inc header)
	W 2700mm
Code	MBKC/** £787.67

** Please add code of colour required - see opposite page



Kit D	
Panels	6 panels
Headers	3 headers
Display	H 2000mm (inc header)
	W 3600mm
Code	MBKD/** £813.00

** Please add code of colour required - see opposite page



Kit E	
Panels	10 panels
Headers	5 headers
Display	H 2000mm (inc header)
	W 5400mm
Code	MBKE/** £1269.17

** Please add code of colour required - see opposite page

Components

Components sold individually to create your own layout or extend your existing system.

Due to its consistent interchangeable design, you can extend, replace or change the colour scheme of your system with ease.

Extra Panels	
900 x 900mm	49204N/** £85.00
900 x 1200mm	49205N/** £86.33
900 x 1800mm	49207N/** £120.67
1200 x 1200mm	49208N/** £103.33
1200 x 1800mm	49209N/** £122.17

** Please add code of colour required - see opposite page

Extra Header Panels	
200 x 900mm	49211N/** £31.17
200 x 1200mm	49212N/** £33.33
200 x 1800mm	49213N/** £38.00

** Please add code of colour required - see opposite page

Extra Poles	
One piece pole and base	49214N £78.07
Split pole and base	49218N £92.57
Header Pole	49215N £16.00





OnBoard® Expandable Display Systems

Due to its modular design, the user can reconfigure and extend the display system to meet the application.

Standard 600 x 900mm panels can be mounted portrait or landscape on to the 1800mm pole using C clips provided.

Components are available separately to extend the system at any point in the future.

Available with black or grey framework.

Large range of 14 loop nylon colours.

All panels are double sided with a choice of loop nylon covering which accepts Velcro®, BusyFix® and pins.

Header panels have loop nylon fabric on one side and black on reverse for optional personalising.



6 Panel + header

Size H 2000mm
W 2100mm
Weight 9.5kg
Black frame **880001/****
£255.19
Grey frame **880002/****
£255.19

** Please add code of colour required



6 Panel

Size H 1800mm
W 1800mm
Weight 9kg
Black frame **880003/****
£242.53
Grey frame **880004/****
£242.53

** Please add code of colour required



7 Panel

Size H 1800mm
W 1800mm
Weight 10kg
Black frame **880005/****
£292.71
Grey frame **880006/****
£292.71

** Please add code of colour required



8 Panel

Size H 1800mm
W 2400mm
Weight 10.5kg
Black frame **880007/****
£307.53
Grey frame **880008/****
£307.53

** Please add code of colour required



10 Panel

Size H 1800mm
W 3000mm
Weight 14.5kg
Black frame **880009/****
£372.71
Grey frame **880010/****
£372.71

** Please add code of colour required



Header set

Size H 200mm
W 600mm
Black frame **880013/****
£30.83
Grey frame **880016/****
£30.83

** Please add code of colour required



Header set

Size H 200mm
W 900mm
Black frame **880014/****
£32.92
Grey frame **880017/****
£32.92

** Please add code of colour required



Panel

Size H 900mm
W 600mm
Black frame **880012/****
£34.63
Grey frame **880018/****
£34.63

** Please add code of colour required

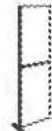

Pole set

Black **880015**
£27.88
Grey **880019**
£28.08

Bags

To Fit
6 panel system **DB1020**
£40.03
7 panel system **DB1021**
£39.03
8 panel system **DB1021**
£39.03
10 panel system **DB1022**
£73.64

Loop nylon cloth colours



GrandStand Expandable Display Systems

New lightweight pole and panel display system offers a larger uninterrupted display area.

Large 900 x 900mm or 900 x 1200mm panels.

900 x 1200mm panels can be mounted portrait or landscape.

2 piece poles in lightweight steel.

14 colours of Velcro® friendly loop nylon which also accepts pins.

2 header panels per kit:

- 1 Colour matched loop nylon both sides.
- 2 Black on one side/white on reverse for your own lettering.

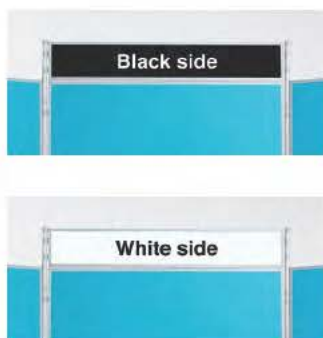

Kit A

6 x 900 x 900mm panels plus 2 headers.

Overall size: 2000(H) x 2700mm(W).

Over 5 square metres of display area, both sides.

Height 2000mm
 Display H 1800mm
 W 2700mm
 Code **770001/****
£445.51

** Please add code of colour required



Kit B

3 x 1200 x 900mm panels plus 2 headers.

Overall size: 2000(H) x 3600mm(W).

Over 3 square metres of display area, both sides.

Height 2000mm
 Display H 900mm
 W 3600mm
 Code **770003/****
£321.62

** Please add code of colour required



Loop nylon cloth colours





MultiBoard Mobile Presentation System



EASY MOUNTING



PEN TRAY



FLIP PAD CLIPS



JOINING PLATES

A exhibition system for displaying artwork, photography, large format drawings, etc.
 Whiteboard variants are ideal for brainstorming, interactive sessions and presentations.
 Large aluminium framed panel measuring 1500 x 1200mm that mounts portrait or landscape between sturdy steel legs.
 Total height of 1950mm when mounted either portrait or landscape.
 Adjustable button feet for stable positioning.
 Can be used in straight line or curved arcs due to unique angled feet (12 panels create a circle).
 Castor sets available to make the boards mobile.
 Joining plates supplied to lock adjacent panels.
 2 double sided display options to choose from.



Pinnable System
 Both sides are fabric covered and accepts pins.

Blue /Blue
 Code **79101**
£235.80



Pin and Write System
 One side fabric covered and one side magnetic whiteboard.

Blue /Whiteboard
 Code **79102**
£256.28



Castor Feet
 2 locking
 Available to fit both models.

Set of 4 **79201**
£15.62

Rope and Pole Barrier System

Traditional rope and pole system.
 Poles are 975mm high and available in a choice of chrome or matte black.
 Plush 2m long rope in either Black, Blue or Red.
 Ropes attach securely to the circular fixings below the attractive spherical finials.
 Heavy base for stability.



Rope colours



Black Pole
 Size H 975mm
 Black **ROP100**
£81.68



Chrome Pole
 Size H 975mm
 Chrome **ROP200**
£111.41



Rope
 Size L 2000mm
 Black rope **ROP300**
 Blue rope **ROP301**
 Red rope **ROP302**
£39.46

Retractable Barrier System

Contemporary retractable tape system.
 Posts are 977mm high and available in a choice of chrome or matte black.
 2m long tape in either Black, Blue or Red.
 Each tape unfurls from its integral cassette to clip securely to the adjacent post.
 Heavy base for stability.

Tape colours



Black post
 Post height 977mm
 Tape length 2000mm
 Black tape **RET100**
 Blue tape **RET101**
 Red tape **RET102**
£135.45



Chrome post
 Post height 977mm
 Tape length 2000mm
 Black tape **RET103**
 Blue tape **RET104**
 Red tape **RET105**
£163.44



BusyScreen® Curve Floor and Desktop Divider Screens





Floor Screens

32mm thick partition screens with rounded upper corners and a rounded edge trim.

2 stabilising feet per panel, optional castor feet for mobility.

Available in a large selection of woven or loop nylon colourways.

A range of 11 sizes in 5 height options.

The foot design prevents twisting and fits securely into the base of each screen.

Optional castor feet available in lieu of stabiliser feet.



Height 900mm
Width 1000mm
Black trim **BA9010/B/****
Grey trim **BA9010/G/****
£140.00

** Please add code of colour



Height 1200mm
Width 1000mm
Black trim **BA1210/B/****
Grey trim **BA1210/G/****
£159.82

Width 1200mm
Black trim **BA1212/B/****
Grey trim **BA1212/G/****
£168.77



Height 1450mm
Width 1200mm
Black trim **BA1412/B/****
Grey trim **BA1412/G/****
£176.14

** Please add code of colour



Height 1600mm
Width 1000mm
Black trim **BA1610/B/****
Grey trim **BA1610/G/****
£171.05

Width 1200mm
Black trim **BA1612/B/****
Grey trim **BA1612/G/****
£172.46

Width 1600mm*
Black trim **BA1616/B/****
Grey trim **BA1616/G/****
£198.25

** Please add code of colour
* Available in Woven Cloth only



Height 1800mm
Width 1000mm
Black trim **BA1810/B/****
Grey trim **BA1810/G/****
£197.89

Width 1200mm
Black trim **BA1812/B/****
Grey trim **BA1812/G/****
£201.23

Width 1600mm*
Black trim **BA1816/B/****
Grey trim **BA1816/G/****
£206.84

** Please add code of colour
* Available in Woven Cloth only

Castor Feet
Supplied in lieu of stabiliser feet
Code **BS73382**
£37.33

** Please add code of colour

Desk Screens

400mm high to attach to the edge of work desks.
32mm thick pinnable partition screens.
Rounded upper corners and a rounded edge trim.
Large selection of Woven or Loop Nylon colourways.
Available in a range of 6 lengths.

NB. Pair of clamps or brackets required per screen:

- 1 Clamp style suitable for most desks.
- 2 Screw on bracket for thicker tops or where under frames cause an obstruction.



Height 400mm
Width 800mm
Black trim **BA4080B/****
Grey trim **BA4080G/****
£66.42

Width 1000mm
Black trim **BA4010B/****
Grey trim **BA4010G/****
£78.58

** Please add code of colour

Height 400mm
Width 1200mm
Black trim **BA4012/B/****
Grey trim **BA4012/G/****
£82.75

Width 1400mm
Black trim **BA4014/B/****
Grey trim **BA4014/G/****
£88.75

** Please add code of colour

Height 400mm
Width 1600mm
Black trim **BA4016/B/****
Grey trim **BA4016/G/****
£91.08

Width 1800mm
Black trim **BA4018/B/****
Grey trim **BA4018/G/****
£101.75

** Please add code of colour

Woven cloth colours



Traditional loop nylon cloth colours



Pair of clamps
Fits desks between 12-30mm thick.
Code **BS00223**
£14.67



Pair of brackets
Fits desks over 30mm thick.
Code **BS71445**
£12.83

BusyScreen® Classic Floor and Desktop Divider Screens



Floor Screens

Display, divide and partition with one standard product.

32mm thick to provide an excellent acoustic shadow.

Available in a large selection of woven or loop nylon colourways.

Each screen is supplied with a pair of stabilising feet, height adjustable button feet and a flexible linking strip.

Available in a choice of 3 different heights and up to 6 different widths.

Curved screens are supplied with button feet only and are intended for use adjoining other screens but should not be used stand alone.

Optional castor feet available for mobility.

All manufactured to FIRA standard.



Castor Feet
Supplied in lieu of stabiliser feet
Code **RMA/9**
£37.33



Height 1225mm
Width 1131mm
Black trim **CB1211/****
Grey trim **CB1211G/****
£240.18

** Please add code of colour



Height 1525mm
Width 1131mm
Black trim **CB1511/****
Grey trim **CB1511G/****
£282.94

** Please add code of colour



Height 1825mm
Width 1131mm
Black trim **CB1811/****
Grey trim **CB1811G/****
£301.96

** Please add code of colour



Height 1225mm
Width 900mm
Black trim **BB1290/****
Grey trim **BB1290G/****
£164.00

Width 1000mm
Black trim **BB1210/****
Grey trim **BB1210G/****
£173.51

Width 1200mm
Black trim **BB1212/****
Grey trim **BB1212G/****
£176.49

Width 1500mm
Black trim **BB1215/****
Grey trim **BB1215G/****
£185.44

Width 1600mm
Black trim **BB1216/****
Grey trim **BB1216G/****
£194.21

Width 1800mm
Black trim **BB1218/****
Grey trim **BB1218G/****
£215.44

** Please add code of colour



Height 1525mm
Width 900mm
Black trim **BB1590/****
Grey trim **BB1590G/****
£190.70

Width 1000mm
Black trim **BB1510/****
Grey trim **BB1510G/****
£195.44

Width 1200mm
Black trim **BB1512/****
Grey trim **BB1512G/****
£202.11

Width 1500mm*
Black trim **BB1515/****
Grey trim **BB1515G/****
£209.47

Width 1600mm*
Black trim **BB1516/****
Grey trim **BB1516G/****
£210.70

Width 1800mm*
Black trim **BB1518/****
Grey trim **BB1518G/****
£221.58

** Please add code of colour



Height 1825mm
Width 900mm
Black trim **BB1890B/****
Grey trim **BB1890G/****
£211.05

Width 1000mm
Black trim **BB1810/****
Grey trim **BB1810G/****
£210.18

Width 1200mm
Black trim **BB1812/****
Grey trim **BB1812G/****
£210.70

Width 1500mm*
Black trim **BB1815/****
Grey trim **BB1815G/****
£220.88

Width 1600mm*
Black trim **BB1816/****
Grey trim **BB1816G/****
£222.46

** Please add code of colour
* Available in Woven Cloth only

** Please add code of colour



Desk Screens

Available in both wave and straight topped versions.
 Straight desk screens measure 400mm deep.
 Wave desk screens measure 400 to 600mm deep.
 32mm thick partition screens.
 Available in a large selection of woven or loop nylon colourways.

NB. Pair of clamps or brackets required per screen:
 1 Clamp style suitable for most desks.
 2 Screw on bracket for thicker tops or where under frames cause an obstruction.



Pair of clamps
 Fits desks between 12-30mm thick.
 Code **BS00223**
£14.67



Pair of brackets
 Fits desks over 30mm thick.
 Code **BS71445**
£12.83

Height 400mm	Height 400 - 600mm
Width 800mm	Width 800mm
Black trim BB4080B/**	Black trim BB6480B/**
Grey trim BB4080G/**	Grey trim BB6480G/**
£67.04	£85.08
Width 1000mm	Width 1000mm
Black trim BB4010B/**	Black trim BB6410B/**
Grey trim BB4010G/**	Grey trim BB6410G/**
£88.44	£100.58
Width 1200mm	Width 1200mm
Black trim BB4012B/**	Black trim BB6412B/**
Grey trim BB4012G/**	Grey trim BB6412G/**
£90.37	£106.08
Width 1400mm	Width 1400mm
Black trim BB4014B/**	Black trim BB6414B/**
Grey trim BB4014G/**	Grey trim BB6414G/**
£75.11	£120.75
Width 1600mm	Width 1600mm
Black trim BB4016B/**	Black trim BB6416B/**
Grey trim BB4016G/**	Grey trim BB6416G/**
£88.27	£123.08
Width 1800mm	Width 1800mm
Black trim BB4018B/**	Black trim BB6418B/**
Grey trim BB4018G/**	Grey trim BB6418G/**
£89.67	£132.08

** Please add code of colour



Woven cloth colours



Traditional loop nylon cloth colours



BusyScreen® Classic Triple Safety Set

This popular mobile triple screen set is supplied with two way linking strips and castor feet; giving maximum safety and mobility.

Linking strips are easily removed to enable the screens to be stacked together for storage.

Choose from 3 popular screen heights and a wide range of fabric options.

Woven cloths are traditional and hardwearing whilst loop nylon has the advantage of being Velcro® friendly.

Panels are supplied with a choice of Grey or Black trim.



Panels: 3 panels	Panels: 3 panels	Panels: 3 panels
Size H: 1225mm	Size H: 1525mm	Size H: 1825mm
W: 1200mm	W: 1200mm	W: 1200mm
Black trim: TSS4B/**	Black trim: TSS3B/**	Black trim: TSS1B/**
Grey trim: TSS4G/**	Grey trim: TSS3G/**	Grey trim: TSS1G/**
£529.12	£605.09	£630.53

** Please add code of colour - see previous page

BusyScreen® Accessories



Wall Linking Batten

For joining one end of a BusyScreen® to a wall.

Code **RMA/8**
£23.10



Hook Over Whiteboard

279 x 358mm.
Fits all BusyScreen® models.

Code **G4158**
£50.59



Hook over coat hook

Box of 6.
Fits all BusyScreen® models.

Code **G4224BL**
£15.48



Hook Over Shelf

Fits all BusyScreen® models except the Connect system.

	Size: W 700mm D 300mm	Code: RMA/6 £72.08
	Size: W 800mm D 300mm	Code: RMA/5 £72.25
	Size: W 900mm D 300mm	Code: RMA/4 £73.25

Coat Stands

Classic

A budget priced coat stand featuring a classic design in matte black that also accepts up to 4 umbrellas.

All black steel frame with 5 hat and coat hooks.



Classic Coat Stand

Size	H	1750mm
	W	500mm
	D	500mm
Code		VA119
		£80.76

Handy

Compact coat and umbrella stands.

These popular coat stands also house up to 6 umbrellas with a built in drip tray.

38cm heavy cast steel base for stability.

Choice of Silver with 5 wooden hangers or all black frame with 5 matching hangers.



Handy Stand

Size	H	1870mm
	W	380mm
	D	380mm
Silver		VA100
		£87.63
Black		VA118
		£82.56

Silver

Compact coat and umbrella stands.

This popular coat stand also houses up to 6 umbrellas with a built in drip tray.

38cm heavy cast steel base for stability.



Silver Coat Stand

Size	H	1750mm
	W	380mm
	D	380mm
Code		VA101
		£121.78

Coat Hooks

Mesh

Simple steel mesh design.

Large rounded hooks to protect your clothing.

Available in a choice of 2, 3 or 5 hook versions.

Contemporary black coated steel and mesh with concealed keyhole fixings supplied.



Mesh 2 hook

Size	H	140mm
	W	216mm
	D	76mm
Code		G6401BL
		£19.53

Mesh 3 hook

Size	H	140mm
	W	375mm
	D	76mm
Code		G6402BL
		£23.23

Mesh 5 hook

Size	H	140mm
	W	680mm
	D	76mm
Code		G6403BL
		£34.19



Brushed Steel

Styled in brushed steel and aluminium finish.

These sturdy aluminium curved coat hooks are fitted to a brushed steel base which arcs out from the wall to conceal the fixings which are supplied.

Choice of 2, 3 or 4 hook versions.



Steel 2 hook

Size	H	127mm
	W	178mm
	D	114mm
Code		G4203SL
		£25.05

Steel 3 hook

Size	H	127mm
	W	273mm
	D	114mm
Code		G4204SL
		£31.08

Steel 4 hook

Size	H	127mm
	W	362mm
	D	114mm
Code		G4205SL
		£37.23





Deluxe Secure Coat Rail

All black coat rack with secure coat hangers.
This attractive unit is supplied with 17 x 2 piece security coat hangers to prevent loss.
Also takes umbrellas and bags.
Locking castors.
Easy self assembly.

Size H 1600mm
W 1220mm
D 520mm
Code **VA120**
£370.41



Silver Coat Rail

Store coats, bags and accessories on this free standing unit.
Finished in silver powder coated steel frame with wooden features.
High capacity hanging rail includes 6 matching hangers.
Supplied with four castors to aid mobility.
Easy self assembly.

Additional steel hangers
Matching coat hangers finished in metallic grey steel with light wood fittings.
Available in a pack of 6.

Stand
Size H 1800mm
W 1140mm
D 550mm
Code **VA103**
£298.21

Hangers
Pack of 6 **VA104**
£50.39



Uplighter

Elegant floor standing uplighter.
Provides controllable background lighting to a maximum of 200w.
Foot dimmer to adjust brightness.
Matte black finish with subtle green decal.

Size H 1800mm
Head diameter 320mm
Base diameter 290mm
Code **VA105**
£79.14



Wall Mounted Clocks

Giant Clock

A large analogue clock with 600mm diameter dial.

Large black numbers for extra clarity.

ABS case finished in silver.

Takes an AA battery.

3 year warranty.



Giant clock

Size W 600mm
D 50mm

Code **VA115**
£139.36

Big Clock

Ultra clear large diameter analogue wall clock.

380mm diameter clock with large black numbers.

ABS case finished in Satin Silver.

Takes one AA 1.5v Battery (not supplied).



Big clock

Size W 380mm
D 50mm

Code **VA111**
£45.42

LED Clock

Illuminated clock with digital display.

A modern, eye-catching clock with a circle of LEDs that move with the time.

50mm high numerals for clarity.

Mains operated.

LED clock

Size W 300mm
D 40mm

Code **VA116**
£79.00



Coloured Clocks

Inexpensive range of analogue wall clocks.

Clear 300mm diameter white faced clock with black numbering available with a range of coloured bezels.

Choose from grey, black, green, purple, red or white.

Takes one AA 1.5v Battery (not supplied).

3 year warranty.



GREY



BLACK



GREEN



PURPLE



RED



WHITE

Coloured clock

Size W 300mm
D 55mm

Grey **VA107**

Black **VA108**

Green **VA114**

Purple **VA109**

Red **VA110**

White **VA106**

£22.42

Shield® Glazed Display Cases

Display 3D objects in style with the Shield® Glazed Display Cases.
 Manufactured to the highest standard.
 Heavy duty yet contemporary aluminium framing with toughened safety glass.
 Available in a choice of wall mounted or freestanding units.
 All units are lockable and supplied with glass shelving as illustrated.
 Satin anodised aluminium or a choice of 4 bright powder coat colours.
 Supplied ready assembled.

Illuminated versions
 Spotlights are clipped into a 12 volt track.
 Lights rotate for directional positioning.
 The lights are simple to remove when not required or for sensitive displays.



Frame colours



Tower unit
 Size H 2000mm
 W 600mm
 D 600mm
 Aluminium **GS1002**
 £1424.24
 Coloured **XS1002/****
 £1666.67

Illuminated
 Aluminium **GS1002L**
 £1878.79
 Coloured **XS1002L/****
 £2121.21

** Please add code of colour



Tower unit
 Size H 2000mm
 W 500mm
 D 500mm
 Aluminium **GS1003**
 £1227.27
 Coloured **XS1003/****
 £1,469.70

Illuminated
 Aluminium **GS1003L**
 £1681.82
 Coloured **XS1003L/****
 £1924.24

** Please add code of colour



Wide tower
 Size H 2000mm
 W 1200mm
 D 600mm
 Aluminium **GS1006**
 £2106.06
 Coloured **XS1006/****
 £2409.09

Illuminated
 Aluminium **GS1006L**
 £2560.61
 Coloured **XS1006L/****
 £2863.64

** Please add code of colour



Wide tower
 Size H 2000mm
 W 1000mm
 D 500mm
 Aluminium **GS1007**
 £1990.91
 Coloured **XS1007/****
 £2293.94

Illuminated
 Aluminium **GS1007L**
 £2445.45
 Coloured **XS1007L/****
 £2748.48

** Please add code of colour



Tower with cupboard
 Size H 2000mm
 W 1200mm
 D 600mm
 Aluminium **GS1004**
 £2133.33
 Coloured **XS1004/****
 £2436.36

Illuminated
 Aluminium **GS1004L**
 £2587.88
 Coloured **XS1004L/****
 £2890.91

** Please add code of colour



Tower with cupboard
 Size H 2000mm
 W 1000mm
 D 500mm
 Aluminium **GS1005**
 £1954.55
 Coloured **XS1005/****
 £2257.58

Illuminated
 Aluminium **GS1005L**
 £2409.09
 Coloured **XS1005L/****
 £2712.12

** Please add code of colour



CONTEMPORARY STYLING AND ILLUMINATED OPTIONS ENHANCE THE DISPLAYED OBJECTS



Wall cabinet

Size H 900mm
W 1200mm
D 200mm

Aluminium **GS1000**
£1003.03
Coloured **XS1000/****
£1184.85

Wall cabinet

Size H 1000mm
W 1000mm
D 200mm

Aluminium **GS1001**
£963.64
Coloured **XS1001/****
£1145.45

Illuminated

Aluminium **GS1000L**
£1457.58
Coloured **XS1000L/****
£1639.39

Illuminated

Aluminium **GS1001L**
£1418.18
Coloured **XS1001L/****
£1600.00

** Please add code of colour

** Please add code of colour



Meeting Room Tables



A simple design, yet practical and sturdy.

These tables have a 25mm Beech or Walnut effect laminate top.

60mm diameter, height adjustable legs unscrew for storage or transportation.

Joining links are available for more permanent requirements.



Tables







		
Small round table	Large round table	Square table
Size H 735mm W 800mm D 800mm	Size H 735mm W 1000mm D 1000mm	Size H 735mm W 800mm D 800mm
Weight 14kg	Weight 20kg	Weight 17kg
Beech 216604/BH	Beech 216605/BH	Beech 216606/BH
Walnut 216604/WA	Walnut 216605/WA	Walnut 216606/WA
£162.42	£171.52	£156.36
		
Rectangular table	Trapezoid table	Semi-circular table
Size H 735mm W 1600mm D 800mm	Size H 735mm W 1600mm D 692mm	Size H 735mm W 1600mm D 800mm
Weight 24kg	Weight 21kg	Weight 21kg
Beech 216600/BH	Beech 216601/BH	Beech 216602/BH
Walnut 216600/WA	Walnut 216601/WA	Walnut 216602/WA
£201.82	£183.64	£183.64



Table Layout Suggestions



Layout above
 Size H 735mm
 W 3197mm
 D 2985mm
 3 x Trapezoid
 Beech **216601/BH**
 Walnut **216601/WA**
 2 x Rectangular
 Beech **216600/BH**
 Walnut **216600/WA**
£954.55

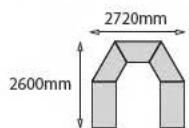
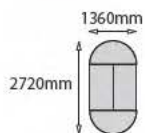

Layout above
 Size H 735mm
 W 1600mm
 D 3200mm
 2 x Semi-circular
 Beech **216602/BH**
 Walnut **216602/WA**
 2 x Rectangular
 Beech **216600/BH**
 Walnut **216600/WA**
£770.91

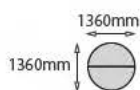

Layout above
 Size H 735mm
 W 1600mm
 D 1600mm
 2 x Semi-circular
 Beech **216602/BH**
 Walnut **216602/WA**
£367.27



Fixing kit
 To join any 2 tables
 Pair **214603**
£24.44



FOR CHAIRS SEE OVER ▶



EasyFold® Meeting Room Tables

A range of modular folding tables that enable you to create alternative layouts.
 Heavy duty folding legs with adjustable feet
 Only 75mm deep when folded flat.
 Beech effect finish with tough ABS edging, complimented with black under frame and legs.
 Fixing links are available to join tables for more permanent configurations.

Tables



Rectangular table
 Size H 735mm
 W 1350mm
 D 680mm
 Weight 24kg
 Code **215600**
£332.82



Trapezoid table
 Size H 735mm
 W 1360mm
 D 590mm
 Weight 23kg
 Code **215602**
£340.91



60° segment table
 Size H 735mm
 W 600mm
 D 680mm
 Weight 23kg
 Code **215604**
£366.06



Semi-circular table
 Size H 735mm
 W 1360mm
 D 680mm
 Weight 23kg
 Code **207122**
£340.91



Quadrant link
 Size H 735mm
 W 680mm
 D 680mm
 Weight 10kg
 Code **215609**
£91.30

Fixing plates
 To join any 2 tables
 Pair **207160NB**
£29.11

Modesty Panels
 While stocks last,
 call us for details.



Table Layout Suggestions

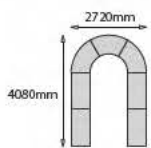

Layout above

Size H 735mm
W 2720mm
D 4080mm

3 x 60° Segment

Code **215604**

4 x Rectangular

Code **215600**
£2429.46

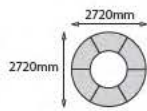

Layout above

Size H 735mm
W 2720mm
D 2720mm

6 x 60° Segment

Code **215604**
£2196.36

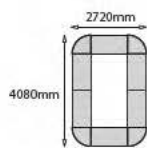

Layout above

Size H 735mm
W 2720mm
D 4080mm

6 x Rectangular

Code **215600**
4 x Quadrant Link
Code **215609**
£2362.12

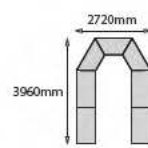

Layout above

Size H 735mm
W 2720mm
D 3960mm

3 x Trapezoid

Code **215602**
4 x Rectangular
Code **215600**
£2354.01

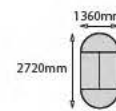

Layout above

Size H 735mm
W 1360mm
D 2720mm

2 x Semi-circular

Code **207122**
2 x Rectangular
Code **215600**
£1347.46

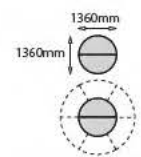

Layout above

Size H 735mm
W 1360mm
D 1360mm

2 x Semi-circular

Code **207122**
£681.82

Meeting Room Chairs

Padded Conference Chairs

Stacking conference chair offering comfort and value
 Available in three woven cloth colours with black or chrome framework
 Offered with or without arms
 Writing tablets and chair connectors available
 Chair stacks max.10 high for optimum storage
 Sold in sets of 4 chairs

Black frame

Size H 820mm
 W 545mm
 D 425mm

Sets of 4

Without arms **94015/4/****
£328.00
 With arms **94016/4/****
£490.52

** Please add code of colour

Chrome frame

Size H 820mm
 W 545mm
 D 425mm

Sets of 4

Without arms **94017/4/****
£345.19
 With arms **94018/4/****
£507.70

** Please add code of colour

Accessories

Writing tablet

Size W 375mm
 D 275mm
 Black - Right **94028/R**
 Black - Left **94028/L**
£58.48
 Beech - Right **94028/BR**
 Beech - Left **94028/BL**
£64.89

Chair connectors

Black **94021**
£4.30
 Chrome **94022**
£8.56



Chair fabrics



Break Out Chairs

Fashionable zingy colours and comfortable yet durable polypropylene chair
 Available in glossy lime green, red or white
 High quality chromium plated metal frame
 Stackable up to 6 high for useful storage
 Sold in sets of 4 chairs

Chair

Size H 830mm
 W 512mm
 D 475mm

Sets of 4

Red **94033**
 Lime **94034**
 White **94035**
£738.67

Chair colours





Standard Folding Lectern

Impressive lectern that folds flat for easy storage
 Finished in beech effect with tough ABS edging
 Both lecterns are only 190mm deep when closed
 Supplied assembled



Floor Standing

Floor standing lectern with large sloping and accessory shelves

The shelves and two hinged side panels fold flat to aid moving and storage

Sloping shelf has a ledge to aid the presenter

Floor Standing

Open Size H 1240mm
 W 620mm
 D 460mm

Weight 29kg
 Floor **215517**
£288.54

Tabletop

Tabletop lectern with large sloping shelf and paper ledge

The shelf and 2 hinged side panels fold flat to aid portability and storage

Tabletop

Open Size H 500mm
 W 620mm
 D 460mm

Weight 14kg
 Desktop **215513**
£162.88





Coloured or Beech Panel Front Lecterns



New contemporary colour finishes for our best-selling mobile panel front lectern

The lecterns feature an angled upper shelf with a steel book rest and a lower accessory shelf

4 castors, 2 of which are locking

Simple self-assembly

Made in the UK

Beech
Popular mobile lectern finished in beech laminate with a grey steel framework

Coloured
Available in a range of 7 colour options with a dark grey steel framework

A colourful edition to the popular beech version

Size	H 1200mm W 600mm D 450mm
Beech	215521 £230.79
Black	214421/BK
Blue	214421/BL
Red	214421/RD
White	214421/WH
Lime	214421/LM
Grey	214421/GY
Orange	214421/OR £252.46



BEECH



BLACK



BLUE



RED



WHITE



LIME



GREY



ORANGE



Acrylic top lectern

Lightweight stylish lectern

A simple lectern with an aluminium post and acrylic top which features a 20mm document retaining lip

Requires simple self assembly

Note

Lightweight design, not designed to carry heavy weight or be leaned on

Size	H 1110mm
Sloping top	W 470mm
	D 320mm
Code	LD3090 £122.20



Audio Visual Furniture - Mobile TV Stands



Secure Mobile TV Stand

Mount up to 50" TV sets.
 Modern and stylish stand for large flat screen TVs with unique features.
 Integral cable tidy as part of stand design, via removal back cover.
 Tilting VESA plate suitable for 75 x 75mm, 100 x 100mm, 200 x 100mm and 200 x 200mm mounting patterns.
 Optional universal mounting bracket for large or non VESA sets. Maximum hole pitch for the universal bracket is 720 x 455mm (W x H).
 Max load capacity is 45kg.
 Optional shelves quickly mount and demount to the stand. The locking cabinets fit to the stand from within therefore increasing security.
 A cabinet with a locking door that passes infrared signals is available.
 Supplied with 60mm heavy duty wheels (2 locking) and adjustable button feet.



Removable back cover for cabling

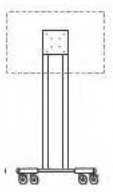

White stand
 Size H 1650mm
 W 900mm
 D 770mm
 Code **215781**
£322.50

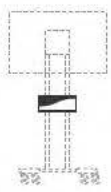

IR cabinet
 Size H 210mm
 W 550mm
 D 420mm
 Beech **215688**
£100.86

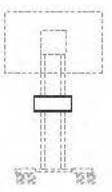

Standard cabinet
 Size H 210mm
 W 550mm
 D 420mm
 Beech **215686**
£91.42

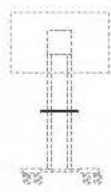

Shelf
 Size H 30mm
 W 450mm
 D 300mm
 Beech **215682**
£44.31

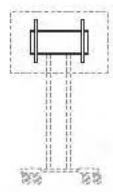

Universal bracket
 Code **215684**
£73.64

Black **215789**
£97.97

Black **215787**
£88.42

Black **215783**
£43.19

215681 + 215781



215688



215686



215783



215684



Audio Visual Furniture - Projector stands

Secure MM Projector Trolley



215715DL

Key Features

- ✓ Twin column mobile trolley
- ✓ Two height adjustable platforms
- ✓ Platforms rotate and tilt
- ✓ Optional shelf and management cover

Twin column trolley for extra stability and capacity. Mobile multi-media trolley with two independently height adjustable platforms that can both rotate and angle.

Robust steel trolley mounted on 4 castors, two of which are lockable.

Deluxe MM Trolley

Additional 300 x 350mm shelf and cable management cover.



Mobile MM trolley

Min Height 800mm
Max Height 1250mm
Each Platform W 350mm
D 400mm

Code **215715**
£298.32



Deluxe MM trolley

Min Height 800mm
Max Height 1250mm
Each Platform W 350mm
D 400mm

Code **215715DL**
£350.46

Column 125 Projector Trolley



125 Trolley 215721

Key Features

- ✓ Height adjustable mobile trolley
- ✓ Height adjustable platform
- ✓ Lockable platform tilting
- ✓ Optional side platform

This mobile multi-media trolley has a height adjustable platform that can also tilt for optimum projector positioning.

Platform measures 380 x 420mm and can angle and lock in place; also making it ideal for use as a lectern.

Mounted on 4 castors, 2 of which are lockable.

Optional side platform.



125 trolley

Min Height 700mm
Max Height 1100mm
Platform W 380mm
D 420mm
Weight 15kg

Code **215721**
£164.06



Side platform

Size W 395mm
D 300mm

Code **215723**
£57.86

Folding Projector Stand



202001

Key Features

- ✓ Lightweight folding stand
- ✓ Economical option
- ✓ Compact storage
- ✓ Tilt adjustable top platform

This economical projector stand folds flat for easy carrying and compact storage. The large upper platform has tilt adjustment, the second lower platform folds flat when not in use.

Tubular steel frame with adjustable foot to assist stability on uneven floors.

Folding stand

Height 1150mm
Top Platform W 600mm
D 400mm
Bottom Platform W 280mm
D 450mm
Weight 10kg

Code **202001**
£142.49

Audio Visual Furniture - Locking Projector Cabinets



MM80 Multi-media Projector Cabinets

Economical multi-media cabinets.
 Low cost solution to housing your multi-media projector and associated equipment.
 Cable accessory port on top and side. 3 shelves - 1 sliding. 100mm wheels - 2 locking.
 Locking door with 2 keys. Supplied ready assembled.



- Size H 930mm
W 524mm
D 570mm
- Beech **MM80**
£272.58
- Red Door **MM80RD**
£277.42
- Blue Door **MM80BL**
£277.42

MM90 Multi-media Projector Cabinets

Best selling premier mobile multi-media cabinets
 Market leading cabinet with extra security features.
 Designed to house all your multi-media projection equipment.
 Three point door lock and locking rear access panel.
 3 slide out and 1 fixed shelf.
 Additional cable ports and cable tidy.
 Accessory storage tray to inside of door.
 100mm soft tyred wheels, 2 locking.
 Supplied ready assembled.



- Size H 930mm
W 524mm
D 570mm
- Beech **MM90**
£320.76
- Red Door **MM90RD**
£327.58
- Blue Door **MM90BL**
£327.58



MM80 WITH RED DOOR

MM80 WITH BLUE DOOR

MM90 WITH BLUE DOOR

MM90 WITH RED DOOR

MM100 Coloured Mobile Multi-Media Cabinets

Designed to accommodate your multi-media projector, DVD player, amplifier, laptop, speakers and all your accessories.

Rear lockable access door provides easy access to cabling and connections for your AV equipment.

4 shelves, 3 of which slide.

3 cable access points.

Generous 100mm wheels (2 with brakes).

Cable tidy and accessory tray inside door.

Supplied ready assembled.

The MM100 also features soft edged platforms to reduce the risk to decor while manoeuvring the cabinet from room to room.

Size H 930mm
W 524mm
D 570mm

Code **MM100/****
£388.79



** Please add code of colour required



BLACK



GREY



WHITE



BLUE



RED



LIME



ORANGE



NEW Rack Mount Cabinet for MM90 and MM100
Now available with a rack mount in place of shelving.
Please ask for further details.



3 SLIDING SHELVES



MATCHING KEYS



CABLE TIDY



CABLE ACCESS POINTS





Projection Screens

- ✓ Largest range of freestanding and fixed screens in the UK
- ✓ Electric and manual operation
- ✓ Professional quality screens

Projection Screens - Freestanding Tripod



Eyeline® Tripod Screens

Portable projection screen with tripod base and matte white cloth with options for borders which enhance the projected image providing a professional presentation.

Heavy duty folding tripod stand.

Fully height adjustable - see column 'E' in dimension chart.

Variable format ratios up to 1:1 square.

Built-in 'keystone' correction.

Integral carry handle for ease of transportation.

5 size models.

Borderless

Plain matte white surface. Entry level budget screen.

With black border

Matte white projection surface with black borders to both sides that enhance the projected image providing a professional presentation.

EYELINE®

Integrated carrying handle



Height adjustable with pole support

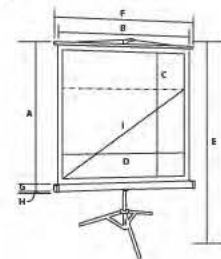

Eyeline Basic Tripod Screen (borderless)

Screen Size	View Area	Format	Max. Height	Case Size	Diagonal in	Weight	Without	Price			
A Height (max)	B Width (max)	C Height (max)	D Width (max)	E	F Length	G Height	H Depth	I	borders Code		
1250mm	1250mm	1250mm	1250mm	1930mm	1290mm	60mm	60mm	61 inch	8.5kg	ET1000	£64.60
1500mm	1500mm	1500mm	1500mm	2380mm	1540mm	60mm	60mm	74 inch	10kg	ET1001	£78.16
1800mm	1800mm	1800mm	1800mm	2680mm	1840mm	60mm	60mm	88 inch	12kg	ET1002	£83.95
2000mm	2000mm	2000mm	2000mm	2880mm	2040mm	70mm	70mm	98 inch	13.5kg	ET1003	£116.27
2400mm	2400mm	2400mm	2400mm	3080mm	2440mm	70mm	70mm	118 inch	18kg	ET1005	£157.72

Eyeline Presenter Tripod Screen (with black border)

Screen Size	View Area	Format	Max. Height	Case Size	Diagonal in	Weight	With borders	Price			
A Height (max)	B Width (max)	C Height (max)	D Width (max)	E	F Length	G Height	H Depth	I	Code		
1250mm	1250mm	1190mm	1190mm	1930mm	1290mm	60mm	60mm	61 inch	8.5kg	LT1000	£73.09
1500mm	1500mm	1440mm	1440mm	2380mm	1540mm	60mm	60mm	74 inch	10kg	LT1001	£92.62
1800mm	1800mm	1740mm	1740mm	2680mm	1840mm	60mm	60mm	88 inch	12kg	LT1002	£116.50
2000mm	2000mm	2940mm	2940mm	2880mm	2040mm	70mm	70mm	98 inch	13.5kg	LT1003	£132.94
2400mm	2400mm	2300mm	2300mm	3080mm	2440mm	70mm	70mm	118 inch	18kg	LT1005	£193.53

Projection Screens - Freestanding



Eyeline® Floor Screens

Portable floor screen with telescopic mast in a choice of 3 format ratios; Square 1:1, Video 4:3 and Widescreen 16:9.
 Steel case floor screen with pivoting stabilising feet.
 Fully height adjustable - see column 'E' in dimension chart.
 Built-in 'keystone' correction.
 Integral carry handle for ease of transportation.
 8 size models.
 Plain matte white surface with black borders.



Integrated carrying handle



Pole support

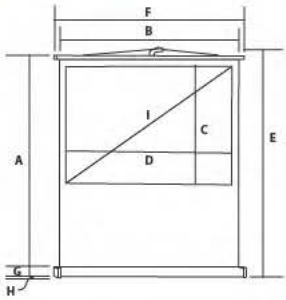

Eyeline Floor Screen												
Screen Size	View Area	Format	Max. Height	Case Size	Diagonal	Weight	Code	Price				
A Height	C Height		E	F Length	I				B Width	D Width	G Height	H Depth
1500mm	1440mm	1:1	2100mm	1535mm	NA	10kg	201460	£128.78	1500mm	1440mm	68mm	70mm
1800mm	1740mm	1:1	2100mm	1835mm	NA	12kg	201462	£138.09	1800mm	1740mm	68mm	70mm
2000mm	1940mm	1:1	2100mm	2035mm	NA	14kg	201458	£157.81	2000mm	1940mm	68mm	70mm
1120mm	1080mm	4:3	2100mm	1535mm	71 inch	10kg	201460V	£127.32	1500mm	1440mm	68mm	70mm
1350mm	1305mm	4:3	2100mm	1835mm	86 inch	12kg	201462V	£133.14	1800mm	1740mm	68mm	70mm
1500mm	1455mm	4:3	2100mm	2035mm	96 inch	14kg	201458V	£156.36	2000mm	1940mm	68mm	70mm
1010mm	979mm	16:9	2100mm	1835mm	79 inch	12kg	201462AW	£144.75	1800mm	1740mm	68mm	70mm
1130mm	1091mm	16:9	2100mm	2035mm	88 inch	14kg	201458AW	£156.36	2000mm	1940mm	68mm	70mm



Eyeline® Vertigo Scissor Floor Screens

This stylish Vertigo® deluxe screen has an assisted lift scissor mechanism to enable a single handed operation, the screen can simply be raised out of the case to your chosen viewing height.

Tough aluminium case.

Stabilising feet rotate for storage when not in use.

Fully height adjustable - see item 'E' in dimension chart.

Integral carry handle for ease of transportation.

4 size models.

Plain matte white surface with black borders.

Available in Widescreen 16:9 or 16:10 and Video 4:3 formats.

Widescreen format



EYELINE

Eyeline® Vertigo Scissor Floor Screen												
Screen Size	B Width	View Area	D Width	Format	Max. Height	Case Size	G Height	H Depth	Diagonal	Weight	Code	Price
A Height		C Height			E	F Length			I			
1200mm	1600mm	1155mm	1540mm	4:3	2100mm	1715mm	90mm	120mm	76 inch	10kg	VG8000	£278.22
1000mm	1600mm	1000mm	1540mm	16:10	2100mm	1715mm	90mm	120mm	72 inch	10kg	VG9001	£301.43
900mm	1600mm	866mm	1540mm	16:9	2100mm	1715mm	90mm	120mm	70 inch	10kg	VG6001	£286.92

Eyeline® Movielux floor screens

Contemporary freestanding floor screen with a superior flat screen surface and crisp black borders for unrivalled picture quality.

Unique base design allows the screen to be totally freestanding without the need for stabilising feet.

Case incorporates a carry handle.

Storage area for the telescopic screen support under case.

Widescreen 16:9, 16:10 and video 4:3 formats.

Matte white projection material with black borders.

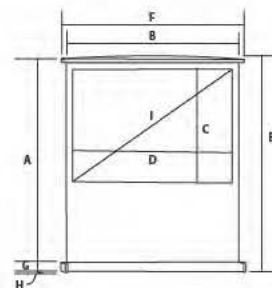

Eyeline® Movielux												
Screen Size	B Width	View Area	D Width	Format	Max. Height	Case Size	G Height	H Depth	Diagonal	Weight	Code	Price
A Height		C Height			E	F Length			I			
1200mm	1600mm	1160mm	1560mm	4:3	1720mm	1700mm	85mm	245mm	77 inch	10.9kg	201464	£210.52
1350mm	1800mm	1310mm	1760mm	4:3	2000mm	1900mm	85mm	245mm	86 inch	12.3kg	201465	£232.52
1000mm	1600mm	975mm	1560mm	16:10	1720mm	1700mm	85mm	245mm	72 inch	10.9kg	201470*	£213.52
1125mm	1800mm	1100mm	1760mm	16:10	2000mm	1900mm	85mm	245mm	81 inch	12.3kg	201471	£236.36
900mm	1600mm	860mm	1560mm	16:9	1720mm	1700mm	85mm	245mm	70 inch	10.9kg	201468	£213.52
1010mm	1800mm	970mm	1760mm	16:9	2000mm	1900mm	85mm	245mm	79 inch	12.3kg	201469	£236.36

* While stocks last

Projection Screens - Freestanding

Speedy-Fold Screens

The ultimate large scale portable screen, Speedy-Fold is simple to erect thanks to the quick release catches and sturdy aluminium sections. Frame sections simply fold out, lock into shape and mount on the T bar feet.

Full screen kit includes frame, legs and screen cloth.

Heavy duty wheeled case for storage and mobility.

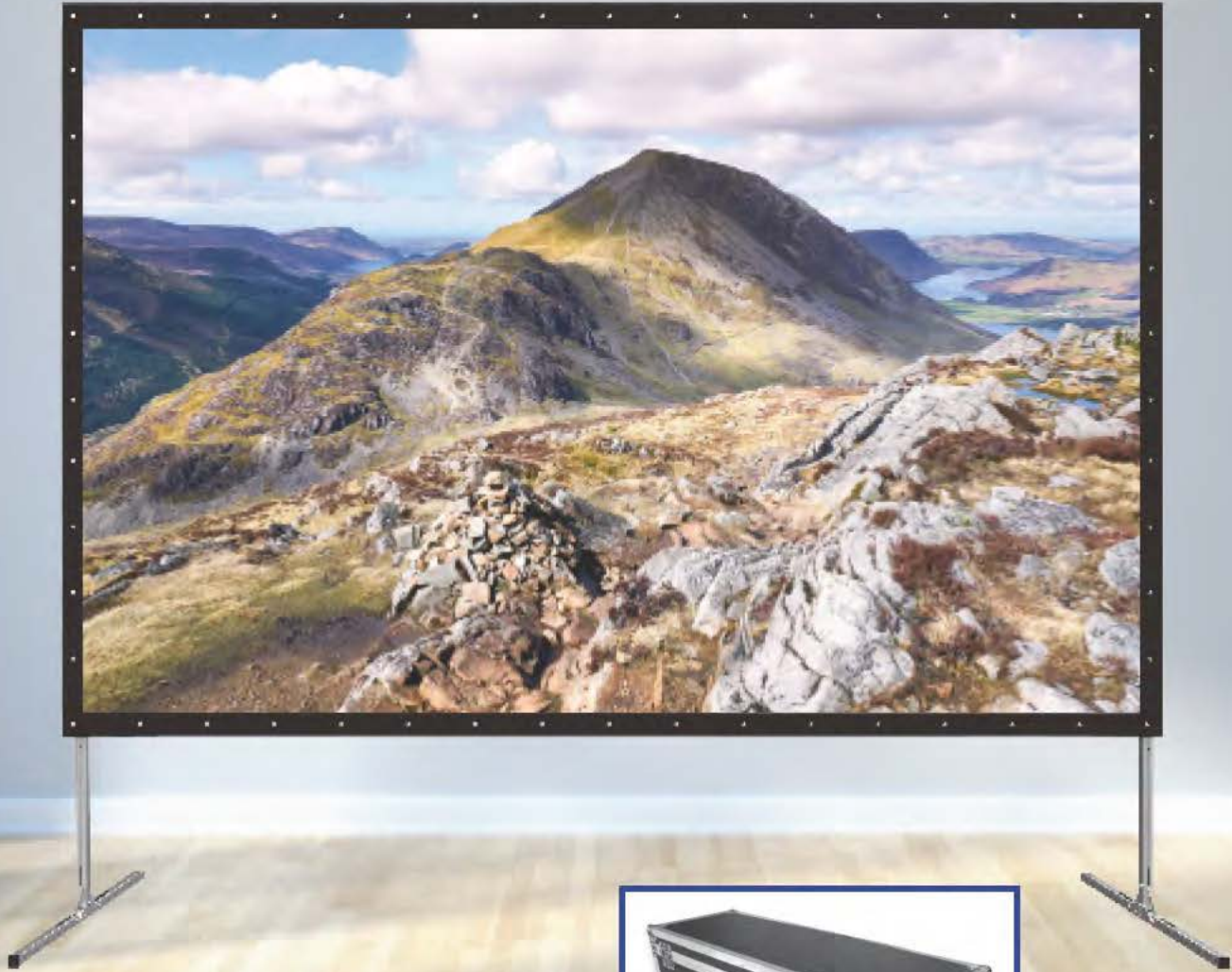
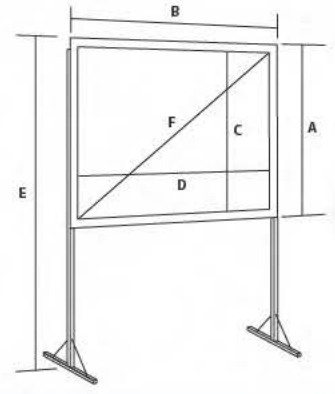

PACKS AWAY IN FLIGHT CASE

Speedy-Fold Large Portable Screens										
Screen Size including Black Borders		View Area		Format	Max Height E	Min Height	Diagonal	Packed Weight in Flight Case	Code	Price
A Height	B Width	C Height	D Width							
1950mm	2575mm	1830mm	2438mm	4:3	2900	2280	120 inch	45kg	282418	£882.67
3190mm	4210mm	3048mm	4064mm	4:3	4200	3600	200 inch	60kg	284030	£1438.44



Ideal for use with your tabletop projector



Eyeline® Tabletop Projection Screen

Portable tabletop projection screen with an impressive 50" (1270mm) diagonal viewing area, yet only weighs 1.65kg.

Compact case houses the screen support mast.

Integral support feet.

Matte white material delivers superb image quality.

EYeLINE

Eyeline® Tabletop												
Screen Size	View Area	Format	Max. Height	Case Size	G Height	H Depth	Diagonal	Weight	Code	Price		
A Height	B Width	C Height	D Width	E	F Length	I	J	K	L	M	N	O
850mm	1055mm	762mm	1016mm	4:3	908mm	1160mm	38mm	65mm	50 inch	1.65kg	SS5500	£75.51



Eyeline® Presenter Wall Screens

Manual pull down projection screen with black borders to all 4 sides that enhance the projected image providing a professional presentation.
 Good quality matte white woven cloth.
 Square 1:1 screen allows for multi format projection.
 Optional extension brackets for clearing obstructions.
 Pull rod available for use with high mounted screens.
 Wall/ceiling fixing through end caps mounting bracket.
 Available as basic borderless design.

Borderless design



Optional extension brackets



End cap fixing



FEATURING SAFETY RETRACTION

All of our manual projection screens now feature a simple slow safety retract mechanism (SSR). Simply release the screen from its open viewing position and let it glide back in to its case unaided. SSR, replacing difficulty with simplicity and safety.

Eyeline® Basic Wall Screens - No Borders													
Screen Size	View Area	Format	Max. Drop	Case Size	Diagonal in	Weight	Code	Price					
A Height (max)	B Width	C Height (max)	D Width	1:1 maximum	E	F Length	G Height	H Depth	video format I				
1250mm	1250mm	1250mm	1250mm	Variable	1338mm	1290mm	68mm	68mm	61 inch	7kg	210301E	£67.38	
1500mm	1500mm	1500mm	1500mm	Variable	1588mm	1540mm	68mm	68mm	74 inch	8kg	210302E	£71.16	
1800mm	1800mm	1800mm	1800mm	Variable	1888mm	1840mm	68mm	68mm	88 inch	10kg	210303E	£79.95	
2000mm	2000mm	2000mm	2000mm	Variable	2088mm	2040mm	68mm	68mm	98 inch	11kg	210304E	£98.82	
2400mm	2400mm	2400mm	2400mm	Variable	2488mm	2440mm	68mm	68mm	118 inch	13kg	210305E	£180.63	
Extension Bracket 550mm 210710 £26.28 Pull Rod for higher screens 200713 £32.09													
Eyeline® Presenter Wall Screens - With Borders													
1500mm	1500mm	1440mm	1440mm	Variable	1588mm	1647mm	68mm	68mm	69 inch	8kg	210302	£79.95	
1800mm	1800mm	1740mm	1740mm	Variable	1888mm	1947mm	68mm	68mm	84 inch	10kg	210303	£92.53	
2000mm	2000mm	1940mm	1940mm	Variable	2088mm	2147mm	68mm	68mm	94 inch	11kg	210304	£108.28	
2400mm	2400mm	2300mm	2300mm	Variable	2488mm	2548mm	68mm	68mm	113 inch	14.5kg	210305	£202.64	
Extension Bracket 550mm 210710 £26.28 Pull Rod for higher screens 200713 £32.09													
Screens include 30mm black borders on all 4 sides except 2400mm model which has 50mm borders.													

Eyeline® Design Manual Screens

Unique patented click-on/click-off channel fix mounting bracket system is very simple to use, with smaller screens being easily fitted by one person.

Contemporary white triangular case appears smaller than similar sized square cased screens.

Brackets can be placed at virtually any length along the screen case which is ideal when mounting to studwork walls or avoiding wires/pipes.

Both wall and ceiling brackets are included, which are hidden from view when installed.

Black borders to all 4 sides enhance the projected image, providing a professional presentation.

Additional black cloth to the top of video 4:3 and widescreen 16:9 models for optimal viewing height.

Optional extension brackets are available for clearing an obstruction or keystone adjustment.

Eyeline® Design Key Features

- ✓ Simple to use mounting
- ✓ Contemporary casing
- ✓ Wall and ceiling brackets included
- ✓ Professional finish black borders
- ✓ Extension brackets available

EYELINE

FEATURING SAFETY RETRACTION

All of our manual projection screens now feature a simple slow safety retract mechanism (SSR). Simply release the screen from its open viewing position and let it glide back in to its case unaided. SSR, replacing difficulty with simplicity and safety.

Electric models
also available
(see overleaf)



Hook on the screen

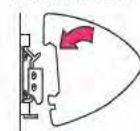

Click into position

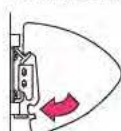

Now ready for use

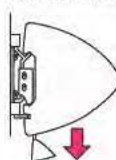

Eyeline® Design Manual Screens													
Screen Size A Height	B Width	View Area C Height	D Width	Format	Max. Drop E	Case Size F Length	G Height	H Depth	Diagonal I	Weight	Code	Price	
1600mm	1600mm	1540mm	1540mm	1:1	1733mm	1697mm	103mm	95mm	NA	9.5kg	EMS16W	£150.74	
1800mm	1800mm	1740mm	1740mm	1:1	1933mm	1897mm	103mm	95mm	NA	10.5kg	EMS18W	£166.85	
2000mm	2000mm	1940mm	1940mm	1:1	2133mm	2097mm	103mm	95mm	NA	12kg	EMS20W	£193.70	
2400mm	2400mm	2300mm	2300mm	1:1	2560mm	2540mm	130mm	111mm	NA	20kg	EMS24W	£303.73	
3000mm	3000mm	2900mm	2900mm	1:1	3160mm	3140mm	130mm	111mm	NA	27.5kg	EMS30W	£521.25	
1200mm	1600mm	1140mm	1540mm	4:3	1733mm	1697mm	103mm	95mm	75 inch	9.5kg	EMV16W	£158.80	
1350mm	1800mm	1290mm	1740mm	4:3	1933mm	1897mm	103mm	95mm	85 inch	10.5kg	EMV18W	£172.21	
1500mm	2000mm	1440mm	1940mm	4:3	2133mm	2097mm	103mm	95mm	95 inch	12kg	EMV20W	£199.06	
1800mm	2400mm	1700mm	2300mm	4:3	2560mm	2540mm	130mm	111mm	113 inch	20kg	EMV24W	£309.09	
2250mm	3000mm	2150mm	2900mm	4:3	3160mm	3140mm	130mm	111mm	142 inch	27.5kg	EMV30W	£537.36	
900mm	1600mm	840mm	1540mm	16:9	1733mm	1697mm	103mm	95mm	69 inch	9.5kg	EMW16W	£164.16	
1020mm	1800mm	960mm	1740mm	16:9	1933mm	1897mm	103mm	95mm	78 inch	10.5kg	EMW18W	£177.60	
1170mm	2000mm	1110mm	1940mm	16:9	2133mm	2097mm	103mm	95mm	88 inch	12kg	EMW20W	£204.45	
1350mm	2400mm	1250mm	2300mm	16:9	2560mm	2540mm	130mm	111mm	103 inch	20kg	EMW24W	£319.84	
1690mm	3000mm	1590mm	2900mm	16:9	3160mm	3140mm	130mm	111mm	130 inch	27.5kg	EMW30W	£550.77	
Extension Bracket 350mm				EBKT30	£51.25	Screens include 30mm black borders on all 4 sides except models 2400mm and above which have 50mm borders. 4:3 and 16:9 models have an additional extended black drop.							

Projection Screens - Wall Mounted Electric



Eyeline® Design Electric Screens

Electrically operated projection screens are supplied as standard with a 3m cable and wall switch.

Same unique patented click-on/click-off channel fix mounting bracket system as the Eyeline® Design Manual Screen on the previous page.

Motor situated on the left hand side when face on.

Requires electrical installation.

Black borders to all 4 sides enhance the projected image, providing a professional presentation.

Additional black cloth to the top of video 4:3 and widescreen 16:9 models for optimal viewing height.

Optional extension brackets are available for clearing an obstruction or keystone adjustment.

Optional key switch, radio frequency or IR remotes - see page 176.

Distinctive triangular case design



Extension Bracket

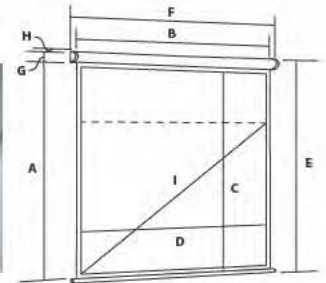

Hook on the screen

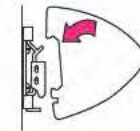

Click into position

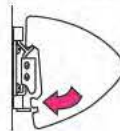

Now ready for use

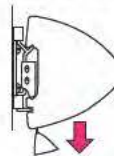

Eyeline® Design electric screens												
Screen Size A Height	B Width	View Area C Height	D Width	Format	Max. Drop E	Case Size F Length	G Height	H Depth	Diagonal I	Weight	Code	Price
1800mm	1800mm	1740mm	1740mm	1:1	1933mm	1897mm	103mm	95mm	NA	10.5kg	EES18W	£328.66
2000mm	2000mm	1940mm	1940mm	1:1	2133mm	2097mm	103mm	95mm	NA	12kg	EES20W	£352.82
2400mm	2400mm	2300mm	2300mm	1:1	2560mm	2540mm	130mm	111mm	NA	20kg	EES24W	£444.83
3000mm	3000mm	2900mm	2900mm	1:1	3160mm	3140mm	130mm	111mm	NA	27.5kg	EES30W	£619.36
1200mm	1600mm	1140mm	1540mm	4:3	1733mm	1697mm	103mm	95mm	75 inch	9.5kg	EEV16W	£291.06
1350mm	1800mm	1290mm	1740mm	4:3	1933mm	1897mm	103mm	95mm	85 inch	10.5kg	EEV18W	£328.66
1500mm	2000mm	1440mm	1940mm	4:3	2133mm	2097mm	103mm	95mm	95 inch	12kg	EEV20W	£347.44
1800mm	2400mm	1700mm	2300mm	4:3	2560mm	2540mm	130mm	111mm	113 inch	20kg	EEV24W	£420.64
2250mm	3000mm	2150mm	2900mm	4:3	3160mm	3140mm	130mm	111mm	142 inch	27.5kg	EEV30W	£605.95
1250mm	2000mm	1190mm	1940mm	16:10	2133mm	2097mm	103mm	95mm	90 inch	12kg	EEL20W	£347.44
1500mm	2400mm	1400mm	2300mm	16:10	2560mm	2540mm	130mm	111mm	106 inch	20kg	EEL24W	£426.03
1875mm	3000mm	1775mm	2900mm	16:10	3160mm	3140mm	130mm	111mm	134 inch	27.5kg	EEL30W	£632.80
900mm	1600mm	840mm	1540mm	16:9	1733mm	1697mm	103mm	95mm	69 inch	9.5kg	EEW16W	£270.32
1020mm	1800mm	960mm	1740mm	16:9	1933mm	1897mm	103mm	95mm	78 inch	10.5kg	EEW18W	£291.45
1170mm	2000mm	1110mm	1940mm	16:9	2133mm	2097mm	103mm	95mm	88 inch	12kg	EEW20W	£347.44
1350mm	2400mm	1250mm	2300mm	16:9	2560mm	2540mm	130mm	111mm	103 inch	20kg	EEW24W	£426.03
1690mm	3000mm	1590mm	2900mm	16:9	3160mm	3140mm	130mm	111mm	130 inch	27.5kg	EEW30W	£632.80
Extension Bracket 350mm				EBKT30	£51.25	Accessories see page 176						

Eyeline® Pro Channel Fix Electric Screens

Professional projection screen for operation by IR remote, 12v trigger or central control system

High quality matte white screen material providing a crisp flat viewing surface.

The view area is framed by 50mm black borders which enhance the image for truly stunning results.

For optimal viewing height, this screen also features an extended black drop.

The screen comes as standard with an infra-red (IR) remote control and IR extension cable for use if the case sensor is obstructed.

12v trigger with a 10m cable for operation when the projector is powered on/off.

RJ11 (6P6C) cable for connection to a RS232 central control system.

Manual override button is also built in underneath the screen for fail safe operation without remote.

Mount to a wall or ceiling using channel fix brackets which can be moved to best fixing points, ie. studs.

No electrical installation required, supplied with a 2.7m cable and plug.

Optional wall switch connects to RJ11 socket.

Eyeline® Pro Key Features

- ✓ High quality matte screen
- ✓ Professional finish black borders
- ✓ Channel fix mounting
- ✓ Variable connectivity
- ✓ No electrical installation required

SEV18

EYELINE

Channel fix mounting

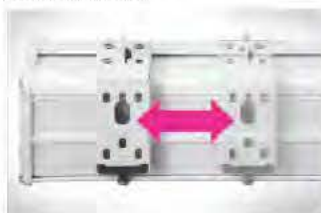

Extension Bracket



Connectivity



IR Sensor and Manual Override



Channel Fix Bracket



Eyeline® Pro Channel Fix Electric Screens

Screen Size A Height	B Width	View Area C Height	D Width	Format	Max. Drop E	Case Size F Length	G Height	H Depth	Diagonal I	Weight	Code	Price	
1200mm	1560mm	1100mm	1460mm	4:3	1980mm	1700mm	102mm	97mm	72 inch	11kg	SEV15*	£370.43	
1380mm	1800mm	1280mm	1700mm	4:3	1980mm	1944mm	102mm	97mm	84 inch	12.5kg	SEV18	£378.25	
1620mm	2130mm	1520mm	2030mm	4:3	1980mm	2270mm	102mm	97mm	100 inch	14.5kg	SEV20	£422.49	
1860mm	2440mm	1760mm	2340mm	4:3	1990mm	2580mm	102mm	97mm	115 inch	16.5kg	SEV24	£462.49	
2390mm	3150mm	2290mm	3050mm	4:3	2640mm	3297mm	102mm	97mm	150 inch	26kg	SEV30	£592.62	
1170mm	1800mm	1070mm	1700mm	16:10	1970mm	1944mm	102mm	97mm	79 inch	10.5kg	SE18ST	£393.87	
1370mm	2130mm	1270mm	2030mm	16:10	1970mm	2270mm	102mm	97mm	94 inch	11.8kg	SE20ST	£414.70	
1560mm	2440mm	1460mm	2340mm	16:10	1960mm	2580mm	102mm	97mm	109 inch	12.3kg	SE24ST	£488.51	
2005mm	3150mm	1905mm	3050mm	16:10	2255mm	3297mm	102mm	97mm	142 inch	26.2kg	SE30ST	£623.85	
990mm	1690mm	890mm	1590mm	16:9	1990mm	1843mm	102mm	97mm	72 inch	11.8kg	SEW16	£375.65	
1060mm	1800mm	960mm	1700mm	16:9	1980mm	1953mm	102mm	97mm	77 inch	12.2kg	SEW18	£393.87	
1250mm	2130mm	1150mm	2030mm	16:9	1950mm	2279mm	102mm	97mm	92 inch	14kg	SEW20	£414.70	
1420mm	2440mm	1320mm	2340mm	16:9	1970mm	2589mm	102mm	97mm	106 inch	16.2kg	SEW24	£488.51	
1600mm	2760mm	1500mm	2660mm	16:9	1950mm	2884mm	102mm	97mm	120 inch	23.4kg	SEW26	£597.84	
1820mm	3150mm	1720mm	3050mm	16:9	2170mm	3297mm	102mm	97mm	138 inch	25.3kg	SEW30	£623.85	
Extension Bracket	350mm	EPB35	£49.42	Wall Switch RJ11	EPW10	£35.62							*While stocks last
Accessories see page 176				Screens include 50mm black borders on all 4 sides. Additional extended black drop is added at top of screen to create maximum drop length.									

Projection Screens - Wall Mounted Electric



Eyeline® Rollfix Heavy Duty Electric Screens

Deluxe heavy duty range of projection screens with a robust steel housing.

Channel mounting system enabling a fast and easy install (channel length 500mm at each end).

Hard wearing heavy duty matte white screen fabric for clear and crisp images.

All models have a 300mm extended black drop which ensures optimum viewing.

40mm black borders to side and bottom.

Requires electrical installation.

Motor situated on the right hand side.

Supplied with wall switch.

For remote control options see page 176.

EYELINE

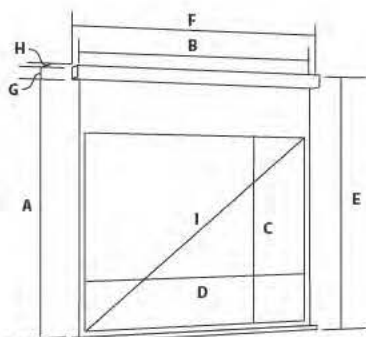

In-ceiling option - see opposite page

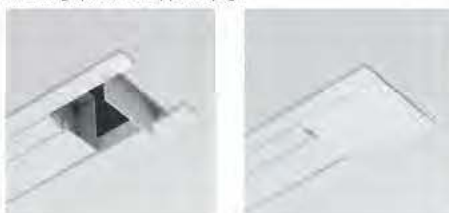

Channel fix mounting



Eyeline® Rollfix Heavy Duty Electric Screens												
Screen Size A Height	B Width	View Area C Height	D Width	Format	Max. Drop E	Case Size F Length	G Height	H Depth	Diagonal I	Weight	Code	Price
1370mm	1800mm	1290mm	1720mm	4:3	1484mm	1940mm	87mm	87mm	2150mm	12.7kg	RFV180*	£584.27
1520mm	2000mm	1440mm	1920mm	4:3	1634mm	2140mm	87mm	87mm	2400mm	14.1kg	RFV200*	£608.95
1820mm	2400mm	1740mm	2320mm	4:3	1934mm	2540mm	87mm	87mm	2900mm	17.1kg	RFV240*	£785.42
2270mm	3000mm	2190mm	2920mm	4:3	2402mm	3140mm	105mm	105mm	3650mm	25.3kg	RFV300*	£1125.93
1160mm	1800mm	1080mm	1720mm	16:10	1274mm	1940mm	87mm	87mm	2031mm	12.4kg	RFST180	£584.27
1280mm	2000mm	1200mm	1920mm	16:10	1394mm	2140mm	87mm	87mm	2264mm	13.8kg	RFST200	£608.95
1530mm	2400mm	1450mm	2320mm	16:10	1644mm	2540mm	87mm	87mm	2736mm	16.7kg	RFST240	£792.87
1910mm	3000mm	1830mm	2920mm	16:10	2042mm	3140mm	105mm	105mm	3446mm	24.8kg	RFST300	£1132.85
1050mm	1800mm	970mm	1720mm	16:9	1164mm	1940mm	87mm	87mm	1975mm	12.3kg	RFW180	£584.27
1160mm	2000mm	1080mm	1920mm	16:9	1274mm	2140mm	87mm	87mm	2203mm	13.7kg	RFW200	£608.95
1390mm	2400mm	1310mm	2320mm	16:9	1504mm	2540mm	87mm	87mm	2664mm	16.6kg	RFW240	£779.54
1720mm	3000mm	1640mm	2920mm	16:9	1852mm	3140mm	105mm	105mm	3349mm	24.7kg	RFW300	£1118.30
Extension Bracket 550mm RFBKT40 £85.78				Screens include 50mm black borders on all 4 sides. Additional extended black drop is added at top of screen to create maximum drop length.							* While stocks last	
Accessories see page 176												

Eyeline® Rollfix In-Ceiling Recess Frame

Convert your Rollfix® screens into a discreet in-ceiling projection screen through the use of a recess frame.

Designed for use in rooms with suspended ceilings, where the case needs to be hidden from view or where wall mounting is not a suitable option.

The recess frame has a sleek white case design that protects the screen and remains almost completely hidden from view when not in use.

Perfect for a professional and discreet installation, ideal for boardroom and hospitality environments.

EYeLINE

Recess Frame Key Features

- ✓ Enables Eyeline Rollfix screen to be mounted discreetly into your ceiling
- ✓ Sleek case design
- ✓ Ideal for boardroom and hospitality installations

1

Select correct size Recess Frame for use with your chosen Rollfix screen (see table).



Simple 3 step guide for in-ceiling conversion

2

Install your Recess Frame into the suspended ceiling



3

Insert your Eyeline Rollfix® screen within the Recess Frame and complete the electrical installation



Eyeline® Rollfix In-Ceiling Recess Frame					
Recess frame size (NOT hole size)		Recess Frame only, for use with Rollfix screens	Price		
Length	Depth				
2186mm	140mm	CR180	£255.67		
2386mm	140mm	CR200	£261.17		
2786mm	140mm	CR240	£273.37		
3386mm	158mm	CR300	£296.04		
2186mm	140mm	CR180	£255.67		
2386mm	140mm	CR200	£261.17		
2786mm	140mm	CR240	£273.37		
3386mm	158mm	CR300	£296.04		
2186mm	140mm	CR180	£255.67		
2386mm	140mm	CR200	£261.17		
2786mm	140mm	CR240	£273.37		
3386mm	158mm	CR300	£296.04		
NB. Never cut the hole in the ceiling until you have your frame with full instructions. The dimensions stated above are a guide to assess suitability only.					

Projection Screens - Wall Mounted Electric

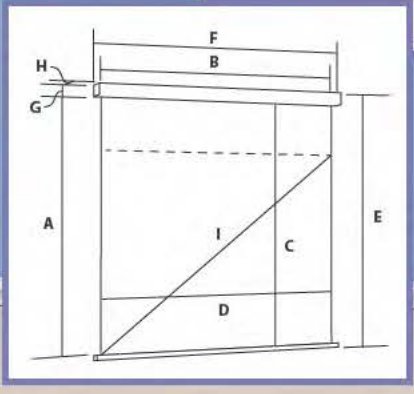
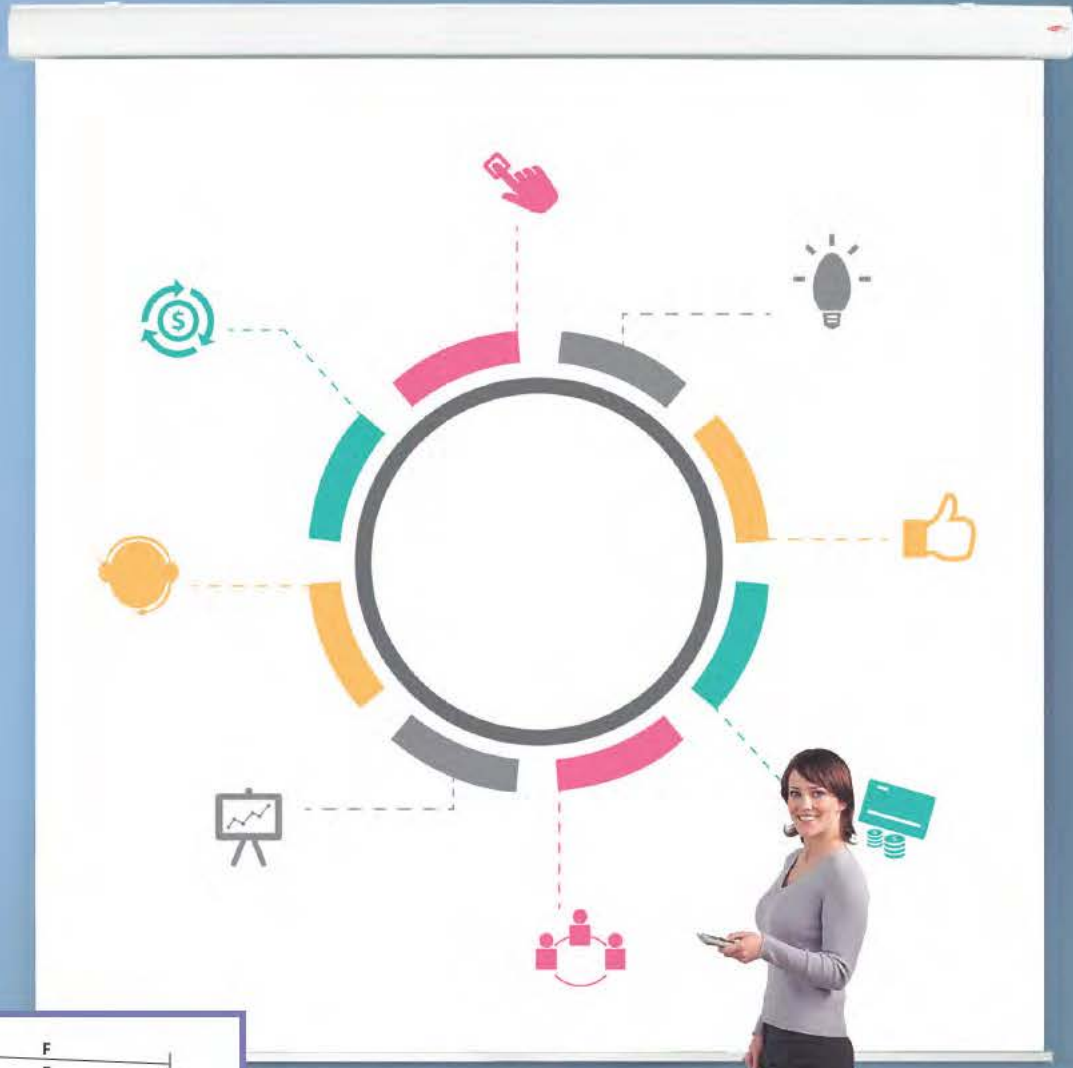

Eyeline® Large Borderless Projection Screens

Large format screens are common place in halls, churches, theatres and auditoriums, with the average screen size increasing year on year. A range of large sized electric screens are now available from stock. The robust channel fix screen case enables fast, secure installation.

Screen is supplied complete with ceiling/wall brackets and electrical wall switch for electrical installation. Matte white projection surface.



Eyeline® Large Borderless Projection Screens																
Screen Size	A Height (max)	B Width	View Area	C Height	D Width	Format	Max. Drop	E	Case Size	F Length	G Height	H Depth	Diagonal	Weight	Code	Price
3500mm	3500mm	3500mm	3500mm	3500mm	3500mm	1:1	3665mm		3600mm	3600mm	145mm	147mm	NA	35kg	213511	£1380.53
4000mm	4000mm	4000mm	4000mm	4000mm	4000mm	1:1	4165mm		4100mm	4100mm	145mm	147mm	NA	42kg	213514	£1600.11
2620mm	3500mm	3500mm	2620mm	2620mm	3500mm	4:3	2785mm		3600mm	3600mm	145mm	147mm	172 inch	34kg	213512	£1335.39
3000mm	4000mm	4000mm	3000mm	3000mm	4000mm	4:3	3165mm		4100mm	4100mm	145mm	147mm	197 inch	41kg	213513	£1550.77

Accessories see page 176

Eyeline® Max Projection Screens

Large format projection screens with black borders to all 4 sides which enhance the projected image, providing a professional presentation.

Channel fix mounting brackets for wall or ceiling.

Quiet motor during operation.

Matte white projection material.

Video 4:3, Widescreen 16:9 and 16:10 formats.

Additional black cloth at the top of all models for optimal viewing height.

Supplied with bare end cable and wall switch.

Optional remote accessories - see page 176.

EYELINE

Channel fix mounting

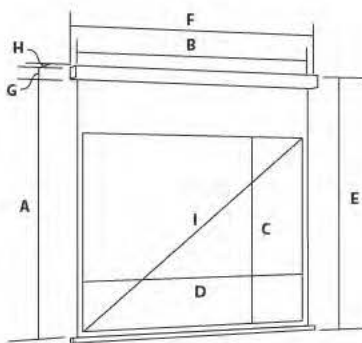

Eyeline® Max Key Features

- ✓ Image-enhancing black borders
- ✓ Channel fix mounting for wall or ceiling
- ✓ Quiet motor
- ✓ Additional black cloth at the top for optimal viewing height
- ✓ Remote accessories available
- ✓ Bare end cable and wall switch supplied

Eyeline® Bespoke Screen Service

We offer a much wider range of screens that are made to order - contact us for further details.



Eyeline® Max Projection Screens

Screen Size A Height	B Width	View Area C Height	D Width	Format	Max. Drop E	Case Size F Length	G Height	H Depth	Diagonal I	Weight	Code	Price
2650mm	3500mm	2550mm	3400mm	4:3	2995mm	3600mm	145mm	147mm	167 inch	30kg	M350V	£1497.84
3020mm	4000mm	2920mm	3900mm	4:3	3365mm	4100mm	145mm	147mm	192 inch	33kg	M400V	£1686.56
3400mm	4500mm	3300mm	4400mm	4:3	3595mm*	4600mm	145mm	147mm	217 inch	36kg	M450V	£1997.07
2230mm	3500mm	2130mm	3400mm	16:10	2875mm	3600mm	145mm	147mm	158 inch	30kg	M350ST	£1497.84
2540mm	4000mm	2440mm	3900mm	16:10	3185mm	4100mm	145mm	147mm	181 inch	33kg	M400ST	£1686.56
2850mm	4500mm	2750mm	4400mm	16:10	3195mm**	4600mm	145mm	147mm	204 inch	36kg	M450ST	£1997.07
2010mm	3500mm	1910mm	3400mm	16:9	2655mm	3600mm	145mm	147mm	154 inch	30kg	M350W	£1497.84
2290mm	4000mm	2190mm	3900mm	16:9	2935mm	4100mm	145mm	147mm	176 inch	33kg	M400W	£1686.56
2570mm	4500mm	2470mm	4400mm	16:9	2915mm**	4600mm	145mm	147mm	199 inch	36kg	M450W	£1997.07

Accessories see page 176

Screens include 50mm black borders on all 4 sides.
Additional extended black drop: 4:3 models have 200mm, 16:9 and 16:10 have 500mm (except * 50mm **200mm)

Projection Screens - Wall mounted electric

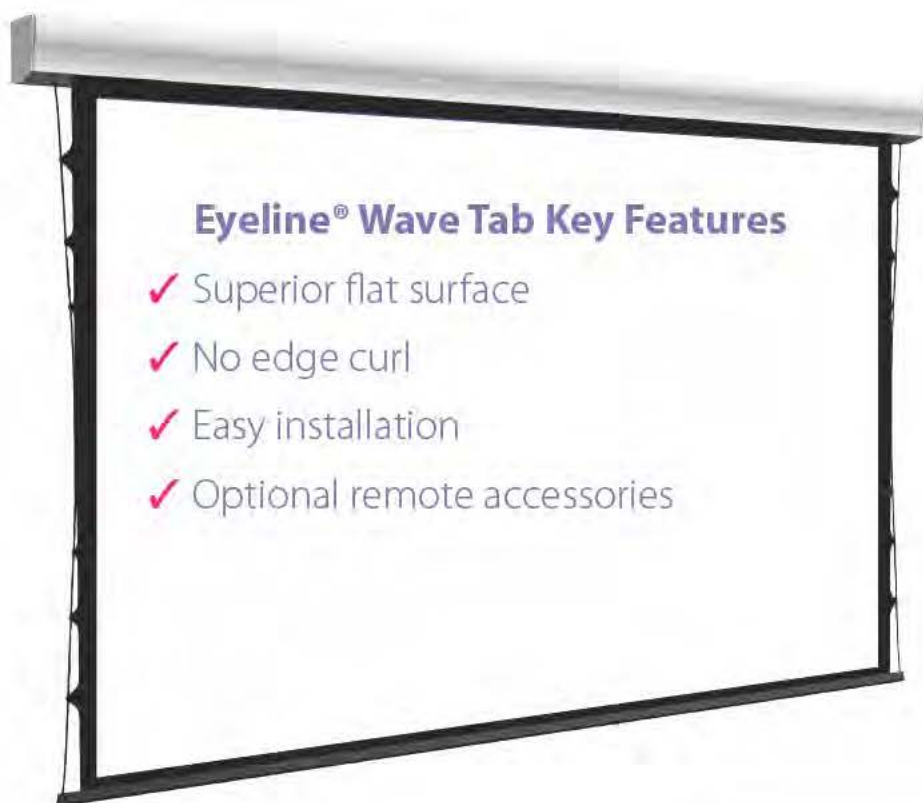

Eyeline® Wave Tab Key Features

- ✓ Superior flat surface
- ✓ No edge curl
- ✓ Easy installation
- ✓ Optional remote accessories



Eyeline® Wave Tab Tension Screens

Constant tension to the screen edge gives a pure flat ripple free screen without any edge curl.

Superior flat surface which further enhances the projected image.

Available in both front and rear projection materials with matte black borders.

For optimal viewing height, this screen also features an extended black drop.

The sleek and stylish waved aluminium case offers channel fix style mounting for easy installation.

Mount to a wall or ceiling using channel fix brackets.

Supplied with bare end cable and wall switch.

Optional remote accessories - see page 176.

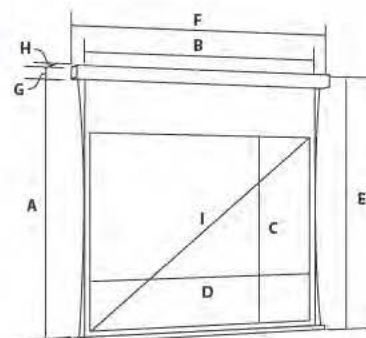

Eyeline® Wave Tab Tention Screens														
Screen Size A Height	B Width	View Area C Height	D Width	Format	Max. Drop E	Case Size F Length	G Height	H Depth	Diagonal I	Weight	Front Projection	Price	Rear Projection	Price
1470mm	1930mm	1370mm	1830mm	4:3	1813mm	2110mm	143mm	157mm	90°	21kg	GTT183V	£1207.01	GTTR183V	£1207.01
1620mm	2130mm	1520mm	2030mm	4:3	1963mm	2310mm	143mm	157mm	100°	23kg	GTT203V	£1263.60	GTTR203V	£1263.60
1770mm	2330mm	1670mm	2230mm	4:3	2113mm	2510mm	143mm	157mm	109°	24kg	GTT223V	£1353.57	GTTR223V	£1353.57
1930mm	2540mm	1830mm	2440mm	4:3	2273mm	2720mm	143mm	157mm	120°	25kg	GTT244V	£1418.61	GTTR244V	£1418.61
2390mm	3150mm	2290mm	3050mm	4:3	2733mm	3330mm	143mm	157mm	150°	28kg	GTT305V	£1678.32	GTTR305V	£1678.32
2840mm	3760mm	2740mm	3660mm	4:3	3183mm	3940mm	143mm	157mm	180°	35kg	GTT366V	£1903.60	GTTR366V	£1903.60
3150mm	4160mm	3050mm	4060mm	4:3	3493mm	4340mm	143mm	157mm	200°	37kg	GTT406V	£2020.93	GTTR406V	£2020.93
1240mm	1930mm	1140mm	1830mm	16:10	1883mm	2110mm	143mm	157mm	85°	21kg	GTT183ST	£1207.01	GTTR183ST	£1207.01
1370mm	2130mm	1270mm	2030mm	16:10	2013mm	2310mm	143mm	157mm	94°	23kg	GTT203ST	£1263.60	GTTR203ST	£1263.60
1630mm	2540mm	1530mm	2440mm	16:10	2273mm	2720mm	143mm	157mm	113°	25kg	GTT244ST	£1418.61	GTTR244ST	£1418.61
2010mm	3150mm	1910mm	3050mm	16:10	2653mm	3330mm	143mm	157mm	142°	28kg	GTT305ST	£1678.32	GTTR305ST	£1678.32
2640mm	4160mm	2540mm	4060mm	16:10	3283mm	4340mm	143mm	157mm	188°	37kg	GTT406ST	£2020.93	GTTR406ST	£2020.93
1130mm	1930mm	1030mm	1830mm	16:9	1773mm	2110mm	143mm	157mm	83°	21kg	GTT183W	£1207.01	GTTR183W	£1207.01
1240mm	2130mm	1140mm	2030mm	16:9	1883mm	2310mm	143mm	157mm	92°	23kg	GTT203W	£1263.60	GTTR203W	£1263.60
1350mm	2330mm	1250mm	2230mm	16:9	1993mm	2510mm	143mm	157mm	101°	24kg	GTT223W	£1353.57	GTTR223W	£1353.57
1470mm	2540mm	1370mm	2440mm	16:9	2113mm	2720mm	143mm	157mm	110°	25kg	GTT244W	£1418.61	GTTR244W	£1418.61
1820mm	3150mm	1720mm	3050mm	16:9	2463mm	3330mm	143mm	157mm	138°	28kg	GTT305W	£1678.32	GTTR305W	£1678.32
2160mm	3760mm	2060mm	3660mm	16:9	2803mm	3940mm	143mm	157mm	165°	35kg	GTT366W	£1903.60	GTTR366W	£1903.60
2380mm	4260mm	2280mm	4060mm	16:9	3023mm	4340mm	143mm	157mm	183°	37kg	GTT406W	£2020.93	GTTR406W	£2020.93

Accessories see page 176

Eyeline® Rear Projection Electric Screens

Rear projection has the benefit of enhanced, brightness, contrast, noise reduction and shadow free images.

The area in front of the screen is clear for the presenter and the viewing audience.

Rear projection coral material is used and available with or without black borders.

The robust channel fix screen case enables fast secure installation.

Screen is supplied complete with ceiling/wall brackets.

Wall switch for electrical installation.

Video format (4:3) available with and without black borders.

Video format (4:3) with borders has 200mm black drop, widescreen formats (16:9 and 16:10) have a 500mm black drop.

EYELINE

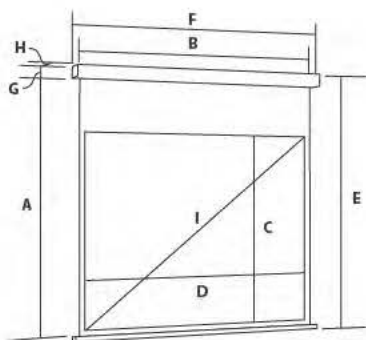

Channel fix mounting

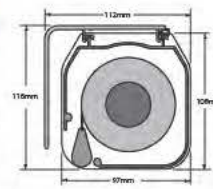

Eyeline® Rear Projection Electric Screens												
Screen Size A Height	B Width	View Area C Height	D Width	Format	Max. Drop E	Case Size F Length	G Height	H Depth	Diagonal I	Weight	Code	Price
1370mm	1800mm	1370mm	1800mm	4:3 no border	1486mm	1880mm	116mm	112mm	89 inch	12kg	RPE18V	£881.56
1900mm	2500mm	1900mm	2500mm	4:3 no border	2016mm	2580mm	116mm	112mm	124 inch	17kg	RPE25V	£1082.58
1370mm	1800mm	1270mm	1700mm	4:3	1686mm	1880mm	116mm	112mm	84 inch	12kg	RPE18VB	£963.47
1900mm	2500mm	1800mm	2400mm	4:3	2216mm	2580mm	116mm	112mm	118 inch	17kg	RPE25VB	£1165.81
1160mm	1800mm	1060mm	1700mm	16:10	1776mm	1880mm	116mm	112mm	79 inch	12kg	RPE18ST	£963.47
1600mm	2500mm	1500mm	2400mm	16:10	2216mm	2580mm	116mm	112mm	111 inch	17kg	RPE25ST	£1165.81
1050mm	1800mm	950mm	1700mm	16:9	1666mm	1880mm	116mm	112mm	77 inch	12kg	RPE18WB	£963.47
1450mm	2500mm	1350mm	2400mm	16:9	2066mm	2580mm	116mm	112mm	108 inch	17kg	RPE25WB	£1165.81
Accessories see page 176												

Projection Screens - Accessories

Eyeline® Electric Screen Accessories

Please see below range of optional accessories suitable for use with electrically operated Eyeline® projection screens that require hard wiring and are supplied as standard with a bare end cable and wall switch.

The below range would be used in place of the wall switch supplied and is suitable for use with the following Eyeline® models:

	PAGE
Eyeline® Design	168
Eyeline® Rollfix	170
Eyeline® Large Borderless	172
Eyeline® Max	173
Eyeline® Wave Tab Tension	174
Eyeline® Rear Projection	175

Please Note:

Radio frequency remotes can be used even if there is an obstruction between the remote and the receiver. Infra-red remotes requires a direct line contact with the receiver, also recommended for areas where other radio frequency signals are used to prevent interference. These products require installation by a qualified electrician.



Eyeline® RF Economy

Entry level RF remote
Screen is operated by radio frequency signal
Supplied with wall receiver and remote

Code **RF101** **£67.22**



Eyeline® RF Control

Smart control wall switch with integrated RF receiver
Wall switch with up/down/stop buttons
Supplied with radio frequency remote
Switch features integrated 12v trigger and RS232 input

Code **RF300** **£103.26**



Eyeline® IR Control

Smart control wall switch with integrated IR receiver
Wall switch with up/down/stop buttons
Supplied with infra-red remote
Switch features integrated 12v trigger and RS232 input

Code **IR200** **£87.12**



Somfy® Key Switch

Keeps your screen safe and prevents casual tampering.
Screen is operated by key
2 keys supplied
Ideal for education

Code **221022** **£65.01**



Somfy® Pro Radio Remote

Market leading professional RF remote control system
Screen operated by radio frequency signal
Supplied with wall receiver and remote

Code **201236** **£158.34**



Somfy® Pro Infra-Red Remote

Market leading professional IR remote control system
Screen operated by infra-red signal
Supplied with wall receiver, IR sensor and remote

Code **201237** **£269.29**

Frame Screens Key Features

- ✓ Semi permanent
- ✓ Ideal for home cinema or office use
- ✓ Velvet covered aluminium frame
- ✓ Superior flat surface
- ✓ Available in a wide range of sizes



80mm profile



Eyeline® Frame Screens

EYELINE

Semi permanent, always in view screens for dedicated areas such as board rooms, conference rooms, training and home cinema rooms.

Velvet covered aluminium frame is 8cm wide and supplied in sections to fix together with ease.

The screen fabric is tensioned and fitted to the rigid frame giving a superior flat surface.

Velvet covered screens have the benefit of a non-reflective, light absorbing surface that increases the perceived contrast of the image.

Available in a wide range of sizes in video 4:3, widescreen 16:9 and 16:10 formats.

Bespoke screens

A wider range of fixed frame screens for front and rear projection are available - please contact us for further details.

Eyeline® Frame Screens											
Screen Size		View Area		Format	Frame Size		Diagonal	Weight	Code	Price	
A Height	B Width	C Height	D Width		E Width	F Depth					G
1360mm	1760mm	1200mm	1600mm	4:3	80mm	40mm	79 inch	11.85kg	EFS16V	£233.00	
1510mm	1960mm	1350mm	1800mm	4:3	80mm	40mm	89 inch	13.28kg	EFS18V	£265.45	
1660mm	2160mm	1500mm	2000mm	4:3	80mm	40mm	98 inch	14.65kg	EFS20V	£287.08	
1990mm	2560mm	1830mm	2400mm	4:3	80mm	40mm	119 inch	17.98kg	EFS24V	£346.58	
2410mm	3160mm	2250mm	3000mm	4:3	80mm	40mm	148 inch	22.31kg	EFS30V	£479.08	
1410mm	2160mm	1250mm	2000mm	16:10	80mm	40mm	94 inch	13.77kg	EFS2012	£300.60	
1660mm	2560mm	1500mm	2400mm	16:10	80mm	40mm	111 inch	15.98kg	EFS2415	£357.39	
2035mm	3160mm	1875mm	3000mm	16:10	80mm	40mm	139 inch	21.07kg	EFS3018	£470.97	
1060mm	1760mm	900mm	1600mm	16:9	80mm	40mm	72 inch	11.87kg	EFS16W	£214.07	
1180mm	1960mm	1020mm	1800mm	16:9	80mm	40mm	81 inch	12.36kg	EFS18W	£254.63	
1280mm	2160mm	1120mm	2000mm	16:9	80mm	40mm	90 inch	13.34kg	EFS20W	£276.27	
1550mm	2560mm	1390mm	2400mm	16:9	80mm	40mm	109 inch	15.67kg	EFS24W	£316.83	
1850mm	3160mm	1690mm	3000mm	16:9	80mm	40mm	136 inch	20.56kg	EFS30W	£425.00	

Reliable AV solutions



Oversize 87" Projection Whiteboard

An oversized semi-matte vitreous enamel steel projection whiteboard designed for use with ultra-short throw projectors.

It's oversized panel allows for calibration of the board whilst still delivering an 87" diagonal image.

The additional grey panel at the top of the board has been designed for the mounting of interactive hardware.

Ideal for short throw projection.

Interactive friendly.

Accepts magnets.

Accepts standard drywipe markers.

For unparalleled picture quality.

3 year surface warranty.

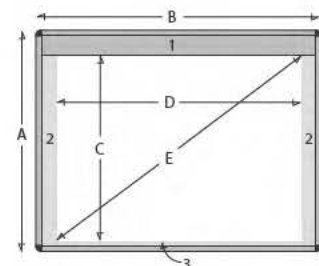

Oversize 87" Projection Whiteboard									
Overall size A Height	B Width	View Area C Height	D Width	Diagonal E	Format	Screen depth	Weight	Code	Price
1343mm	2102mm	1165mm	1864mm	87 inch	16:10	12mm	32kg	PW087	£501.11





Projection Whiteboard

Key Features

- ✓ Dual purpose high quality whiteboard
- ✓ Ideal for projection **and** drywipe markers
- ✓ Position next to standard whiteboard to create a presentation wall
- ✓ 25 year surface warranty

Projection Whiteboard

A high quality vitreous enamel semi matte steel whiteboard suitable for projection and drywipe markers.

Suitable for short throw and ultra short throw projectors.

Ideal for positioning next to standard magnetic whiteboards from Metroplan creating a useful presentation wall - ask for matching 1200mm high whiteboards.

Ideal for short throw projection.

Accepts standard drywipe markers.

25 year surface warranty.

Accepts magnets.

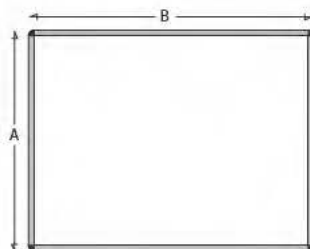

Concealed corner fixing



Projection Whiteboard

Overall size	Screen depth	Weight	Code	Price
A Height	B Width			
1200mm	1800mm	12mm	18kg	PWS18 £262.67
1200mm	2400mm	12mm	22kg	PWS24 £336.65

Reliable AV solutions



Formatted Projection Whiteboards

A choice of 3 formats and 2 frame designs available to suit individual requirements.

A high quality vitreous enamel semi matte steel whiteboard suitable for projection and drywipe markers.

Standard aluminium frame version is suitable for short throw projectors.

Super flat surface for unparalleled picture quality.

4:3, 16:9, 16:10 options.

Accepts standard drywipe markers.

Accepts magnets.

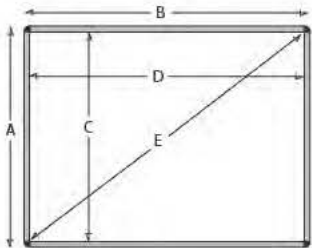

Shield black frame



Standard aluminium frame

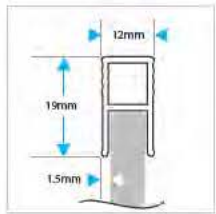
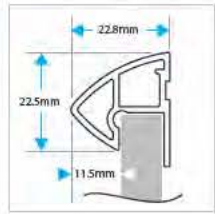

Shield Black Frame										
Overall size	View Area		Diagonal E	Format	Screen depth	Weight	Code	Price		
A Height	B Width	C Height	D Width							
1224mm	1618mm	1181mm	1575mm	78 inch	4:3	23mm	27kg	PW1520	£268.06	
1224mm	1933mm	1181mm	1890mm	88 inch	16:10	23mm	32kg	PW1250	£294.72	
1224mm	2143mm	1181mm	2100mm	95 inch	16:9	23mm	35kg	PW1120	£332.92	
Standard Aluminium Frame										
1218mm	1612mm	1181mm	1575mm	78 inch	4:3	12mm	27kg	PWA1520	£251.81	
1218mm	1927mm	1181mm	1890mm	88 inch	16:10	12mm	32kg	PWA1250	£271.81	
1218mm	2137mm	1181mm	2100mm	95 inch	16:9	12mm	35kg	PWA1120	£310.83	

Please check frame dimensions carefully before ordering

Long Throw Projection Screen Key Features

- ✓ Perfect image display with no hotspot
- ✓ Drywipe marker compatible
- ✓ Clean with microfibre cloth

Long Throw Projection Screen

This matte projection surface is suitable for long throw projectors and will offer a perfect image without a hotspot.



The vitreous enamel surface can be written on using drywipe markers however its main function is as a projection surface.

The surface must be cleaned with a microfibre cloth if markers are used.

A choice of various standard sizes and formats to choose from.

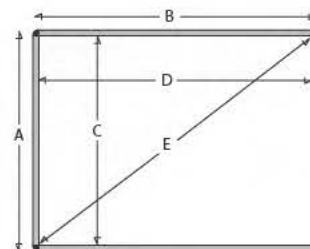

Long Throw Projection Screen									
Overall size		View Area		Diagonal E	Format	Screen depth	Weight	Code	Price
A Height	B Width	C Height	D Width						
1218mm	1942mm	1181mm	1905mm	88 inch	16:10	12mm	32kg	PWL1920	£429.03
1218mm	2162mm	1181mm	2125mm	96 inch	16:9	12mm	35kg	PWL2140	£476.11

A wider range of sizes are available to order for larger quantities





WriteOn® Laptop Whiteboards

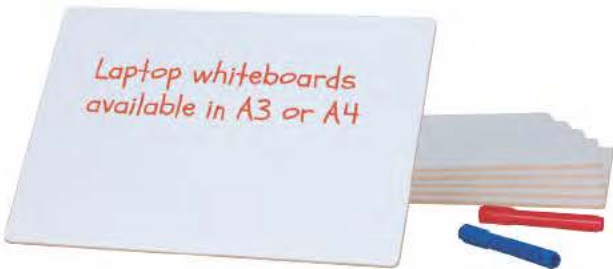

Hand held whiteboards ideal for classroom use
Double sided whiteboards with Guideline® gridded surface one side and plain surface on the reverse.
Smooth radiused corners for safety.
Conveniently supplied in packs of six A4 and A3 boards.

A4 whiteboards
Size H 210mm
W 297mm
Pack of 6 **4984A**
£21.25

A3 whiteboards
Size H 297mm
W 420mm
Pack of 6 **4983A**
£33.39



Add WriteOn® whiteboard pens
Wallet of 4 pens: 1 of each Black, Blue, Red, Green **439115** **£6.93**
For other accessories please see pages 33-37

WriteOn® coloured Laptop Whiteboards



Brightly coloured magnetic whiteboards.
Double sided drywipe whiteboards that have the benefit of also accepting magnets.
The chunky multi-coloured ergonomic frame with rounded corner caps makes the board comfortable and safe to use.

A4 whiteboards
Size H 210mm
W 297mm
Pack of 10 **4964A**
£42.00

Junior Products - Desktop Easels

WriteOn® Big Book Desk Easel

Tabletop easel with big book rest.

Sturdy and lightweight easel.

Perfect angle for displaying big books in class.

The landscape board is 600mm x 800mm with a full width pen tray/ledge.

Hinged rear support ensures the board cannot tilt over, safe classroom use.

Aluminium frame with a drywipe surface that also accepts magnets.



Board size H 600mm
W 800mm
Code **441001**
£85.05



WriteOn® Junior Desk Easels

A compact tabletop easel that can be used by children or staff on classroom tables for drawing, presenting or writing.

Supplied with holder for hanging paper or pads.

Folds for compact storage.

Choice of satin anodised aluminium or brightly coloured trim.

Surface accepts magnets.

Aluminium frame
Board size H 500mm
W 600mm
Code **JDE100M**
£83.99

Multi-coloured frame
Board size H 500mm
W 600mm
Code **JDE101M**
£89.75



Add WriteOn® whiteboard pens

Wallet of 4 pens: 1 of each Black, Blue, Red, Green **439115** **£6.93**

For other accessories please see pages 33-37

WriteOn® Junior Big Book Mobile Storage Easel

Handy mobile easel with storage tray.

Freestanding whiteboard easel.

Steel storage tray base.

Easy to move when angled onto two wheeled legs.

Ideal for use with big books due to full width pen tray and angled board.

Surface accepts magnets.

Board size H 900mm
W 600mm
Height 1350mm
Code **BMBM32**
£169.73





Junior Products - Mobile Easels



WriteOn® Junior Mobile Whiteboards

Practical floor standing mobile junior whiteboard with integral pen tray.

Double sided whiteboard mounted on a mobile frame.

Board can pivot and lock at a 40° angle, therefore ideal for resting books or artwork on the full width ledge.

4 castors, 2 locking. Overall height 1300mm. 2 models, both surfaces accept magnets.

White frame

White coated steel stand with 2 plain aluminium framed whiteboard surfaces.

Red frame

Red coated steel stand with multi-coloured framed whiteboard that has a 50 x 50mm grid on one side and horizontal lines on the reverse.

White frame

Board size H 600mm
W 900mm
Height 1300mm
Code **JPM32**
£132.16

Red frame

Board size H 600mm
W 900mm
Height 1300mm
Code **JPGL32**
£154.73



JPM32



Add WriteOn® whiteboard pens
Wallet of 4 pens: 1 of each Black, Blue, Red, Green **439115 £6.93**
For other accessories please see page 33-37



NEW Junior Art Easels

Easels feature both chalkboard and drywipe whiteboard surfaces.

Paint pot holders and chalk ledges aid the artists. Central shelf for storing art essentials.

Framework is made from 15mm Russian Birch plywood.

Rounded safety edges.

Delivered flat pack for easy assembly.

Paint pots and art materials not included.

Desktop Art Easels

Size H 764mm

W 700mm

D 640mm

10 Months +

Code **AE1000**

£162.00



2 Sided Art Easels

Size H 1092mm 2 years +

W 700mm

D 640mm

Code **AE2000**

£177.80

Size H 1172mm 3 years +

W 700mm

D 640mm

Code **AE3000**

£187.17



3 Sided Art Easels

Size H 1200mm

W 964mm

D 880mm

Code **AE4000**

£229.83



4 Sided Art Easels

Size H 1200mm

W 954mm

D 954mm

Code **AE5000**

£281.17



NEW Junior Products - Art & Play



PLEASE STATE SHELF EDGING COLOUR REQUIRED:



Double Sided Painting Easels

Choice of 4 edging colours: Grey, Red, Blue or Lime.
 Safe hand holes. Manoeuvre on discreet wheels.
 Constructed from 18mm MFC in Maple finish.
 Flat pack for easy self assembly. Made in the UK.

PLEASE STATE EDGE COLOUR REQUIRED (only on A & B).



Low Floor Easel
 Size H 850mm
 W 910mm
 D 700mm
 Code **MXR008**
£161.33



Floor Easel (A)
 Size H 1070mm
 W 910mm
 D 700mm
 Code **MXR0017/****
£291.07
 With 3 clear tubs
 Code **MXR0025/****
£322.73



Tall Floor Easel (B)
 Size H 1300mm
 W 910mm
 D 700mm
 Code **MXR0018/****
£323.70
 With 3 clear tubs
 Code **MXR0026/****
£354.77

Trapease® Paper Hanging System

Ingenious rail for hanging paper or thin card.
 Simply insert paper and then lift and pull upwards to release.
 Ideal for displaying children's artwork or notices.
 Simple wall attachment via snap fixings or adhesive mountings - both supplied.
 Trapease® rails can be used singly or are designed to butt seamlessly end to end for longer runs.
 Can be converted to an all white system.

Code **TE060**
 Size H 54mm
 W 600mm
 D 22mm
£29.39
 Code **TE120**
 Size H 54mm
 W 1200mm
 D 22mm
£40.86
 Code **TE180**
 Size H 54mm
 W 1800mm
 D 22mm
£52.82



Role Play Curriculum Unit

Manufactured from flat pack 18mm MFC with Maple finish.

A versatile unit which can be used for many different role play activities.

Add tubs or baskets for extra storage.

PLEASE STATE SHELF EDGING COLOUR REQUIRED:



Size	H	1300mm	
	W	940mm	
	D	700mm	
Without Tubs	MXR0019	£300.00	
With 3 Clear Tubs	MXR0020	£334.33	
With 3 Wicker Baskets	MXR0021	£366.00	



DISCREET WHEELS



SAFE HAND HOLES



Role Play Kitchens



COMBINATION KITCHEN

Manufactured from flat pack 18mm MFC with Maple finish.

Cooker/fridge/sink/washing machine in one unit.

Safe hand holes.

Manoeuvre on discreet wheels.

Toys not included.

Size	H	520mm
	W	400mm
	L	830mm
Code	MXR0030	£302.08



TWIN KITCHEN

Manufactured from sustainable birch plywood.

2 units: cooker/fridge and sink/washing machine.

Use side by side, back to back or as stand alone.

Size	H	520mm
	W	400mm
	L	830mm
Code	MJK100	£378.93



Sand and Water Table

Manufactured from birch plywood from sustainable forests.

Safe rounded sand or water tub in Clear or Green plastic.

Flat pack for easy self assembly.

Sand and toys not included.

Size	H	280mm
	W	390mm
	D	390mm
Clear tub	MXR0133/CL	
Green tub	MXR0133/GR	£91.98



Dressing Up Unit

Manufactured from MFC from sustainable forests.

A versatile unit which can be used for many different role play activities.

Add tubs or baskets for extra storage.

Clothes and hangers not included.

Size	H	1300mm
	W	940mm
	D	700mm
Code	MXR0019	£258.00



NEW Role Play Panels



These beautifully made coloured panels are ideal for dividing spaces, creating role play areas or simply for display.

Made from Russian Birch plywood in Maple finish with a hardwood frame and colourful uprights, the connecting mechanism has a locking feature at the top for extra safety.

For stability purposes during play please ensure that a minimum of 3 panels are connected together at top and bottom of the panel.

Suitable for 3 years +.

Role Play Kits - buy 3 panels and save £'s



made to order
non returnable
10-15 working
days lead time



Kit 1

- Door Panel
- Plain Panel
- Window Panel

Code **RPP100**
Set of 3 panels
£367.25

Kit 2

- Whiteboard Panel
- Loop Nylon Display Panel
- Chalkboard Panel

Code **RPP200**
Set of 3 panels
£378.07

Kit 3

- Double Door Panel
- Counter Panel
- Chalkboard Panel

Code **RPP300**
Set of 3 panels
£389.85

Choose any combination of panels

Window



Can be used as a house or theatre. The open-ended design allows for a variety of different play scenarios.

Size
H 1200mm
W 800mm
Code **MRP8012/WP**
£135.33

Mirror



Panel features safety mirror, ideal for dressing up areas.

Size
H 1200mm
W 800mm
Code **MRP8012/MP**
£145.60

Chalkboard



Features high quality double sided chalkboard surface.

Size
H 1200mm
W 800mm
Code **MRP8012/BP**
£135.33

Door



Door panel with safety hinge, features letter box, peep hole and door bell.

Size
H 1200mm
W 800mm
Code **MRP8012/DP**
£145.70

Velcro*



Panel with stylish grey loop nylon Velcro* friendly surface

Size
H 1200mm
W 800mm
Code **MRP8012/DG**
£135.33

Whiteboard



Double sided panel with plain whiteboard on one side and a grid on the other.

Size
H 1200mm
W 800mm
Code **MRP8012/NM**
£135.33

Double Door



Panel featuring double door with safety hinges. Space for a header.

Size
H 1200mm
W 800mm
Code **MRP8012/DD**
£145.60

Counter



Counter panel with removable shelf. Whiteboard base panel. Space for a header.

Size
H 1200mm
W 800mm
Code **MRP8012/CP**
£145.60

Maple



A plain maple coloured panel ideal for display or simply use as a space divider. play scenarios.

Size
H 1200mm
W 800mm
Code **MRP8012/PP**
£135.42

Narrow Panel



Maple coloured panel with purple uprights.

Size
H 1200mm
W 480mm
Code **MRP8012/NP**
£118.80

Large Window



An extra wide panel which will allow larger structures such as houses to be created easily.

Size
H 1200mm
W 1000mm
Code **MRP8012/WW**
£145.67

Accessory Kit

Market
Post Office
Library
Shop
Hospital
Vets
Doctors
Bank

Set of 8 acrylic signs designed for use with the window panels. A simple way to create various role play scenarios.

Code **MRP100**
£40.33

NEW Shelving and Storage Units

Choice of 4 edging colours: Grey, Red, Blue or Lime.
 Safe hand holes.
 Manoeuvre on discreet wheels.
 Constructed from 18mm MFC in Maple finish.
 Flat pack for easy self assembly. Made in the UK.

PLEASE STATE SHELF EDGING COLOUR REQUIRED:



DISCREET WHEELS



SAFE HAND HOLES

Double Sided Bench Storage Units

Double Sided Bench Units

Size H 440mm
 W 940mm
 D 450mm

Laminate Topped

- Without Tubs **MXR0002/**** **£161.00**
- With 3 Clear Tubs **MXR0011/**** **£193.73**
- With 3 Wicker Baskets **MXR0012/**** **£213.95**

** Please add code of colour required



Mirror Topped

- Without Tubs **MXR0024/**** **£182.47**
- With 3 Clear Tubs **MXR0023/**** **£203.29**
- With 3 Wicker Baskets **MXR0007/**** **£245.23**

** Please add code of colour required

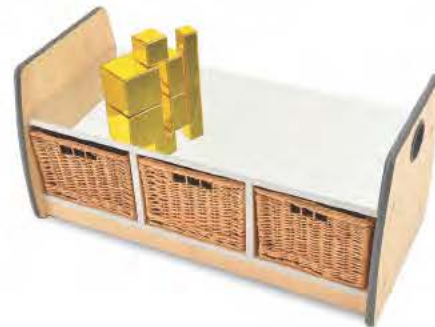

Double Sided Book Storage

Low floor book unit

Size H 440mm
 W 940mm
 D 450mm

- Code **MXR0003/**** **£187.20**

** Please add code of colour required



Floor book unit without tubs

Size H 660mm
 W 940mm
 D 450mm

- Without Tubs **MXR0004/**** **£226.10**
- With 3 Clear Tubs **MXR0013/**** **£257.30**
- With 3 Wicker Baskets **MXR0014/**** **£280.02**

** Please add code of colour required



Arts and Crafts Units

Double Shelf Units

Size H 660mm
 W 940mm
 D 450mm

Paper Storage Backed

With 3 tubs and 3 storage trays

- MXR0027/**** **£268.75**

Triple Shelf Units

Size H 660mm
 W 940mm
 D 450mm

Paper Storage Backed

With 3 tubs and 3 storage trays

- MXR0028/**** **£300.92**

** Please add code of colour required





MIRROR BACKED



CHALKBOARD BACKED



WHITEBOARD BACKED

Shelf Storage Units

Single Shelf Units

Size	H 440mm
	W 940mm
	D 450mm

Double Sided

Empty	MXR0001/**	£138.70
Mirror Backed		
Without Tubs	MXR0039/**	£150.00
With 3 Clear Tubs	MXR0031/**	£182.51
With 3 Wicker Baskets	MXR0032/**	£203.50

** Please add code of colour required

Double Shelf Units

Size	H 660mm
	W 940mm
	D 450mm

Double Sided

Without Tubs	MXR0005/**	£191.10
With 6 Clear Tubs	MXR0009/**	£234.57
With 6 Wicker Baskets	MXR0010/**	£277.87

Mirror Backed

Without Tubs	MXR0041/**	£214.84
With 6 Clear Tubs	MXR0035/**	£258.23
With 6 Wicker Baskets	MXR0036/**	£301.47

Chalkboard Backed

Without Tubs	MXR0040/**	£214.88
With 6 Clear Tubs	MXR0033/**	£256.30
With 6 Wicker Baskets	MXR0034/**	£300.63

** Please add code of colour required

Triple Shelf Units

Size	H 660mm
	W 940mm
	D 450mm

Double Sided

Without Tubs	MXR0006/**	£214.50
With 6 Clear Tubs	MXR0015/**	£255.30
With 6 Wicker Baskets	MXR0016/**	£323.03

Whiteboard Backed

Without Tubs	MXR0042/**	£258.30
With 6 Clear Tubs	MXR0037/**	£300.00
With 6 Wicker Baskets	MXR0038/**	£366.00

** Please add code of colour required

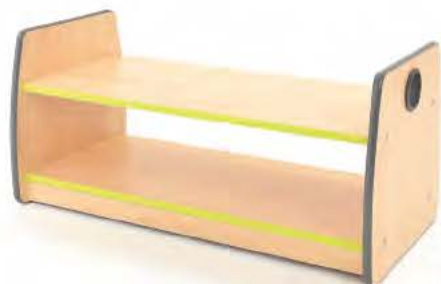



SPREAD LOAD TESTED

LOCKABLE WHEELS

DURABLE RUNNERS AND TRAYS



ColourBox® Quality Features

ColourBox® furniture products are made in the UK to the highest specifications and come with a 10 year warranty against manufacturing defects.

Each model has been spread load tested to take 100kg.

Most units are available on lockable heavy duty wheels with rubber tyres for maximum strength.

All tray storage units use Granelles® plastic runners, designed to complement the large range of Granelles® shallow or deep trays in 20 different colours.

A versatile range of storage furniture

ColourBox® Furniture offers you a new and exciting range of vibrant coloured storage furniture to brighten up your teaching environment, domestic or office space.

We aim to offer you top quality products with the added ingredient of a new and unique selection of contemporary colour finishes to complement the latest trends in decor.

- Made to order to your requirements
- Unique choice of colours and combinations
- Quality - Made to last 10 year Guarantee

- Free direct delivery to most UK mainland addresses
- No assembly required
- Products tested by FIRA

Ordering is simple

- 1 Choose the model of ColourBox® Furniture that best suits your requirements
- 2 Consider if you need a lockable cabinet
- 3 Choose the cabinet colour that best suits your environment, make a note of the colour code
- 4 Choose the tray or tub colour option to compliment your cabinet, add that code

Example

ColourBox® 4 column, shallow tray mobile storage with lockable doors in Tomato colour with 24 Translucent trays and doors

Product code + Box colour + Tray colour
CS64D + Tomato + Translucent

Order code
CS64D/TB/TR





LOCKABLE DOORS



Lockable door options for most models prevent casual interference. Locks are supplied with a set of 2 keys, all keys are keyed alike.

COLOUR MATCHED EDGING



All units are manufactured using 18mm MFC throughout and with colour matched ABS edging.

TUB OR BASKET STORAGE



The Tub storage range has cubby holes for use with general purpose plastic tubs. These can also be purchased with traditional wicker baskets or without tubs to suit.

SAFETY HINGES



All lockable units have quality safety hinges to prevent sagging.

Example order code

CS64D/TB/TR

ColourBox® Furniture colours & codes

Wood Range

BH Beech	MP Maple
--------------------	--------------------

Colour Range

WB White	BK Black	GR Grey	
TB Tomato	BB Blueberry	BN Bean	SY Saffron Yellow
OB Orange	LB Lime	LL Light Lilac	CB Caribbean Blue

Gratnells® Tray Colours (see page 197)

Traditional

FR Flame Red	RB Royal Blue	GG Grass Green	SY Sunshine Yellow	SL Silver	LG Light Grey	TM Mixed
------------------------	-------------------------	--------------------------	------------------------------	---------------------	-------------------------	--------------------

Pop

TO Tropical Orange	PP Plumb Purple	FP Fuchsia Pink	MB Midnight Blue	CB Cyan Blue	JL Jolly Lime	PM Mixed
------------------------------	---------------------------	---------------------------	----------------------------	------------------------	-------------------------	--------------------

Jelly

SJ Strawberry	GJ Grape	BJ Blueberry	KJ Kiwi	LJ Lemon	TR Translucent	JM Mixed
-------------------------	--------------------	------------------------	-------------------	--------------------	--------------------------	--------------------

Domino

JB Jet Black	SW Snow White	DM Mixed
------------------------	-------------------------	--------------------

Tub colours and baskets (see page 198)

BL Blue	RD Red	YW Yellow	TM Mixed	CL Clear	WB Wicker Baskets
-------------------	------------------	---------------------	--------------------	--------------------	-----------------------------

ColourBox® Storage Furniture - Find a home for all your bits and bobs



ColourBox® Storage Furniture - Tray Units

ColourBox® tray storage furniture featuring either the market leading Grattells® shallow trays, or the popular Grattells® deep trays.

Choose any combination of beech, maple or 11 striking colours.

Co-ordinate with 20 tray colour options or 4 popular tray mixes.

Mobile models with 4 castors, 2 of which lock.

Optional locking doors to secure the contents.



Shallow Tray Storage Units



6 x 1
Size H 670mm
W 370mm
D 480mm
Code **CS61/**/****
£166.67

with lockable doors
Code **CS61D/**/****
£208.75



6 x 2
Size H 670mm
W 710mm
D 480mm
Code **CS62/**/****
£225.97

with lockable doors
Code **CS62D/**/****
£309.72

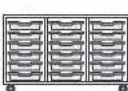

6 x 3
Size H 670mm
W 1050mm
D 480mm
Code **CS63/**/****
£297.92

with lockable doors
Code **CS63D/**/****
£367.36



6 x 4
Size H 670mm
W 1390mm
D 480mm
Code **CS64/**/****
£364.31

with lockable doors
Code **CS64D/**/****
£460.83

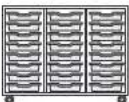

8 x 3
Size H 870mm
W 1050mm
D 480mm
Code **CS83/**/****
£357.08

with lockable doors
Code **CS83D/**/****
£440.56



TRAYS ONLY (Units not included)

Traditional Mixed Code **F16/TM £48.19** Pop Mixed Code **F16/PM £48.19** Jelly Mixed Code **F16/JM £48.19**



Deep Tray Storage Units



3 x 1

Size H 670mm
W 370mm
D 480mm

Code **CD31/**/****
£155.56

with lockable doors

Code **CD31D/**/****
£196.17



3 x 2

Size H 670mm
W 710mm
D 480mm

Code **CD32/**/****
£202.78

with lockable doors

Code **CD32D/**/****
£284.72

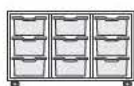

3 x 3

Size H 670mm
W 1050mm
D 480mm

Code **CD33/**/****
£261.11

with lockable doors

Code **CD33D/**/****
£327.56

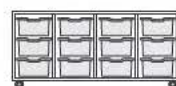

3 x 4

Size H 670mm
W 1390mm
D 480mm

Code **CD34/**/****
£316.67

with lockable doors

Code **CD34D/**/****
£412.81



4 x 3

Size H 870mm
W 1050mm
D 480mm

Code **CD43/**/****
£305.83

with lockable doors

Code **CD43D/**/****
£387.64





ColourBox® Storage Furniture



Mix and Match Tray Storage

Tray storage furniture combining the popular Gratnells® shallow or deep trays to your own configuration.

Create your own combination of deep and shallow trays.

Each deep tray represents the space of 2 x shallow trays.



6 x 1 based on all shallow trays

Size H 670mm
W 370mm
D 480mm

Code **CM61/****
£136.11

with lockable doors

Code **CM61D/****
£178.25



6 x 2 based on all shallow trays

Size H 670mm
W 710mm
D 480mm

Code **CM62/****
£165.83

with lockable doors

Code **CM62D/****
£208.83

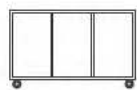

6 x 3 based on all shallow trays

Size H 670mm
W 1050mm
D 480mm

Code **CM63/****
£205.83

with lockable doors

Code **CM63D/****
£274.58

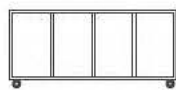

6 x 4 based on all shallow trays

Size H 670mm
W 1390mm
D 480mm

Code **CM64/****
£243.33

with lockable doors

Code **CM64D/****
£340.31

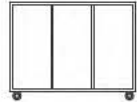

8 x 3 based on all shallow trays

Size H 870mm
W 1050mm
D 480mm

Code **CM83/****
£234.72

with lockable doors

Code **CM83D/****
£315.28

Gratnells® shallow trays in packs of 6

Market leading trays available in a wide choice of 20 colours across 4 ranges with popular mix tray option.

For use with all of our shallow tray storage units and our mix and match units. Dimensions H x W x D : 75 x 312 x 427mm.

Pack of 6 shallow trays £48.19

Traditional range



Flame Red
Code **F16/FR**



Royal Blue
Code **F16/RB**



Sunshine Yellow
Code **F16/SY**



Grass Green
Code **F16/GG**



Silver
Code **F16/SL**



Light Grey
Code **F16/LG**

Pop range



Tropical Orange
Code **F16/TO**



Plum Purple
Code **F16/PP**



Midnight Blue
Code **F16/MB**



Fuschia Pink
Code **F16/FP**



Cyan Blue
Code **F16/CB**

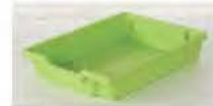

Jolly Lime
Code **F23/JL**

Jelly range



Strawberry
Code **F16/SJ**



Grape
Code **F16/GJ**



Kiwi
Code **F16/KJ**



Blueberry
Code **F16/BJ**



Lemon
Code **F16/LJ**



Translucent
Code **F16/TJ**

Domino range



Snow White
Code **F16/SW**



Jet Black
Code **F16/JB**



Gratnells® deep trays in packs of 3

Market leading trays available in a wide choice of 20 colours across 4 ranges. For use with all of our shallow tray storage units and our mix and match units.

Each deep tray represents the space of 2 x shallow trays. Dimensions H x W x D : 150 x 312 x 427mm.

Pack of 3 deep trays £43.19

Traditional range



Flame Red
Code **F23/FR**



Royal Blue
Code **F23/RB**



Sunshine Yellow
Code **F23/SY**



Grass Green
Code **F23/GG**



Silver
Code **F23/SL**



Light Grey
Code **F23/LG**

Pop range



Tropical Orange
Code **F23/TO**



Plum Purple
Code **F23/PP**



Midnight Blue
Code **F23/MB**



Fuschia Pink
Code **F23/FP**



Cyan Blue
Code **F23/CB**



Jolly Lime
Code **F23/JL**

Jelly range



Strawberry
Code **F23/SJ**



Grape
Code **F23/GJ**



Kiwi
Code **F23/KJ**



Blueberry
Code **F23/BJ**



Lemon
Code **F23/LJ**



Translucent
Code **F23/TJ**

Domino range



Snow White
Code **F23/SW**



Jet Black
Code **F23/JB**





ColourBox® Storage Furniture - Tub Units

Cubby Hole Storage

This versatile cubby hole design can be used with or without tubs and/or baskets.
Choose from beech, maple or 11 striking cabinet colours. Optional locking doors to secure the contents.
Sets of 6 tubs or 3 wicker baskets are also available to purchase separately.
Cubby hole dimensions H220 x W280 x D400mm.

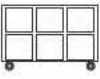

2 x 3
Size H 580mm
W 940mm
D 450mm

Cubby hole **CH23/**** £174.03
With 6 tubs **CT23/**/**** £194.03
With 6 baskets **CT23/**/WB** £290.56

With lockable doors

Cubby hole **CH23D/**** £238.89
With 6 tubs **CT23D/**/**** £258.33
With 6 baskets **CT23D/**/WB** £320.36

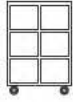

3 x 2
Size H 810mm
W 620mm
D 450mm

Cubby hole **CH32/**** £156.81
With 6 tubs **CT32/**/**** £175.92
With 6 baskets **CT32/**/WB** £237.64

Cubby hole **CH32D/**** £217.58
With 6 tubs **CT32D/**/**** £237.08
With 6 baskets **CT32D/**/WB** £299.08



3 x 3
Size H 810mm
W 940mm
D 450mm

Cubby hole **CH33/**** £188.64
With 9 tubs **CT33/**/**** £217.89
With 9 baskets **CT33/**/WB** £311.81

Cubby hole **CH33D/**** £270.08
With 9 tubs **CT33D/**/**** £299.33
With 9 baskets **CT33D/**/WB** £392.33



Plastic tubs

Purchase spare coloured tubs for your units or buy tubs for cubby hole units purchased earlier.
Available in blue, red, yellow or clear. **Sold in packs of 6 £39.58**



Yellow Code **CT6/YW**



Red Code **CT6/RD**



Blue Code **CT6/BL**



Clear Code **CT6/CL**



Mixed Code **CT6/TM**
2 blue + 2 red + 2 yellow



Pack of 3 Code **CW3**
£60.56

Wicker baskets

Traditional wicker baskets sold in packs of 3

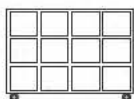

3 x 4

Size H 810mm
W 1220mm
D 450mm

Cubby hole **CH34/**** £216.31
With 12 tubs **CT34/**/**** £255.31
With 12 baskets **CT34/**/WB** £379.31

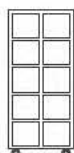

5 x 2

Size H 1220mm
W 620mm
D 450mm

Cubby hole **CH52/**** £213.33
With 10 tubs **CT52/**/**** £245.22
With 10 baskets **CT52/**/WB** £348.56

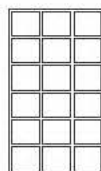

6 x 3

Size H 1530mm
W 940mm
D 450mm

Cubby hole **CH63/**** £341.67
With 18 tubs **CT63/**/**** £399.31
With 18 baskets **CT63/**/WB** £585.36

With lockable doors

Cubby hole **CH34D/**** £312.50
With 12 tubs **CT34D/**/**** £350.56
With 12 baskets **CT34D/**/WB** £474.58

Cubby hole **CH52D/**** £280.92
With 10 tubs **CT52D/**/**** £313.47
With 10 baskets **CT52D/**/WB** £416.78

Cubby hole **CH63D/**** £433.33
With 18 tubs **CT63D/**/**** £491.31
With 18 baskets **CT63D/**/WB** £677.36

Stepped Tub Storage

This storage unit has no back so tubs or wicker baskets can be accessed from both sides.

For safety the unit is supplied as shown without wheels.

Choose any combination of beech, maple or 11 striking colours and combine with coloured tubs, wicker baskets or empty as a cubby hole unit.



Stepped unit

Size H 590mm
W 970mm
D 450mm

Cubby hole **CHS6/**** £161.25
With 6 tubs **CTS6/**/**** £180.78
With 6 baskets **CTS6/**/WB** £241.94





ColourBox® Storage Furniture - Kinderboxes

Kinderbox Tray Storage

This unit has 6 compartments to store books as well as 12 shallow or 6 deep slide out Gratnells® trays.

Choose any combination of beech, maple or 11 striking colours and combine with 20 tray colour options.

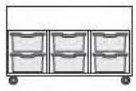

Size H 710mm
W 1050mm
D 480mm

12 Shallow trays **CKS43/**/**** **£281.81**
6 Deep trays **CKD23/**/**** **£259.72**



Kinderbox Tub Storage

This unit has 4 compartments to store books as well as 4 large plastic tubs for general storage.

It is supplied without doors as standard but optional locking doors are available.

Choose any combination of beech, maple or 11 striking colours and combine with 4 tub colours, wicker baskets or with no tubs as a cubby hole unit.



Size H 750mm
W 710mm
D 490mm

Cubby hole **CHT22/**** **£188.89**
With 4 tubs **CKT22/**/**** **£199.72**
With 4 baskets **CKT22/**/WB** **£243.06**

with lockable doors
Cubby hole **CHT22D/**** **£257.72**
With 4 tubs **CKT22D/**/**** **£270.83**
With 4 baskets **CKT22D/**/WB** **£312.06**





Kinderbox General Purpose Storage

This very popular unit has a top that is divided into 6 separate compartments with a multitude of uses.

16 small tubs and 4 larger tubs in 4 colours ideal for keeping small, loose items tidy.

Heavy duty steel wheels bolted through the carcass of the trolley are standard.

Choose from Beech, Maple or 11 striking colours.



Size	H 690mm
	W 900mm
	D 480mm
Code	CKG84/** £298.61

Slimline Kinderbox

Only 300mm deep, this narrow storage unit is ideal where space is limited.

4 compartments to display books on top as well as another 4 storage compartments below.

Choose from Beech, Maple or 10 striking colours.

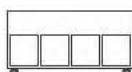

Mobile

Size	H 630mm
	W 1200mm
	D 300mm
Code	CKT14/** £180.42





ColourBox® Storage Furniture - Locking cabinets

ColourBox® Storage Furniture - Locking Cabinets

Tub and Shelf Cabinet

This unit has 8 compartments to take large plastic tubs and 4 shelves secured by locking half doors
Heavy duty steel wheels bolted through the carcass to ensure maximum safety.

Choose any combination of beech, maple or 11 striking colours and combine with 4 tub colours, wicker baskets or empty as a cubby hole unit.
Optional full height locking doors are also available.



Size H 1050mm
W 1222mm
D 450mm

- Cubby hole **CHT44/**** £333.33
- With 8 tubs **CCT44/**/**** £372.22
- With 8 baskets **CCT44/**/WB** £455.56



Order deep and/or shallow trays separately see page 197

Tray and Shelf Cabinet

This unit has 2 wide shelves as well as 6 shallow or 3 deep slide out Gratnells® trays behind a locking door.

Heavy duty steel wheels bolted through the carcass to ensure maximum safety.

Choose any combination of beech, maple or 11 striking colours and combine with 20 tray colour options.

Units are available without trays to specify your own combination - see trays on page 197.

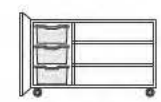

Size H 670mm
W 1050mm
D 480mm

- No trays **CCM6/**** £256.81
- 3 Deep trays **CCD3/**/**** £278.89
- 6 Shallow trays **CCS6/**/**** £291.94





Mobile Combination Cabinet

This unit has a height adjustable wide shelf behind 2 locking doors as well as 18 shallow or 9 deep slide out Gratnells® trays.

Choose any combination of beech, maple or 11 striking colours and combine with 20 tray colour options.

Heavy duty steel wheels for mobility.

Optional full height locking doors are also available.

Units are available without trays to specify your own combination - see trays on page 197.



Size H 1250mm
W 1050mm
D 490mm

No trays **C**CM63/** **£362.78**
9 Deep trays **C**CD33/**/** **£417.92**
18 Shallow trays **C**CS63/**/** **£484.44**



Static Large Cabinet

This unit has 2 height adjustable wide shelves as well as 18 shallow or 9 deep slide out Gratnells® trays, all secured behind 2 full height locking doors.

For safety reasons, this large cabinet is only available as a static unit.

Choose any combination of beech, maple or 11 striking colours and combine with 20 tray colour options.

Units are also available without trays to specify your own combination - see trays on page 197.

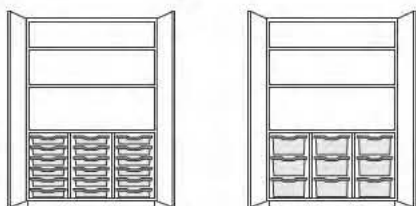

Size H 1800mm
W 1050mm
D 490mm

No trays **C**WM63/** **£468.47**
9 Deep trays **C**WD33/**/** **£518.06**
18 Shallow trays **C**WS63/**/** **£559.72**



Small Cabinet

This unit has 3 narrow shelves as well as 6 shallow and 2 deep slide out Gratnells® trays behind locking doors.

Heavy duty steel wheels are bolted through the carcass to ensure maximum safety.

Choose any combination of beech, maple or 10 striking colours and combine with 20 tray colour options.

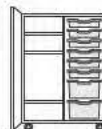

Size H 1020mm
W 710mm
D 490mm

Code **C**C62/**/** **£346.39**



ColourBox® Storage Furniture - Quadrant Units



Quadrant Revolving Circular Unit

This revolving circular unit takes 12 Gratnells® translucent quadrant tubs. 6 locking castors aid manoeuvrability. The whole unit rotates on its base. Ideal for placing centrally in a room. Contrasting grey soft edging protects doorways etc.

	12 tubs
Size	H 640mm
	W 860mm
	D 860mm
Code	CQ34/**
	£486.81

Quadrant Semi-Circular Unit

The semi-circular version takes 6 Gratnells® translucent quadrant tubs. Ideal for placing along a wall or buy 2 to create a static circular unit. Available in 11 unit colours.



	6 tubs
Size	H 588mm
	W 860mm
	D 441mm
Code	CQ32/**
	£265.00

Quadrant Corner Unit

This corner unit takes 3 Gratnells® translucent quadrant tubs. Designed to be sited in the corner of a room or anywhere with a right angled space to fill. Units can be positioned together for a flexible layout.



	3 tubs
Size	H 588mm
	W 441mm
	D 441mm
Code	CQ31/**
	£177.78

Quadrant Corner Shelving

Practical corner shelving units ideal for use with lever arch files and other general storage requirements. 3 size options with 1, 2 or 3 shelves. All units are made from 18mm top quality MFC. Choose from beech, maple or 11 striking colours.



		
1 shelf	2 shelf	3 shelf
H 405mm	H 788mm	H 1171mm
W 384mm	W 384mm	W 384mm
D 384mm	D 384mm	D 384mm
Code CQ51/**	Code CQ52/**	Code CQ53/**
£86.11	£108.33	£120.83



Cloakroom Storage

Two simple designs of storage unit make them ideal for school, office or domestic use.

For safety the units are supplied as shown without wheels.

Choose any combination of beech, maple or 11 striking colours and combine with 4 tub colours, wicker baskets or with no tubs as a cubby hole unit.



1 x 4

Size H 310mm
W 1215mm
D 450mm

Cubby hole **CH14/**** £155.56
With 4 tubs **CT14/**/**** £163.61
With 4 baskets **CT14/**/WB** £204.44



2 x 4

Size H 530mm
W 1215mm
D 450mm

Cubby hole **CH24/**** £181.14
With 8 tubs **CT24/**/**** £207.50
With 8 baskets **CT24/**/WB** £289.81



Plastic tubs

Purchase spare coloured tubs for your units or buy tubs for cubby hole units purchased earlier.

Available in blue, red, yellow or clear. **Sold in packs of 6 £39.58**



Yellow Code **CT6/YW**



Red Code **CT6/RD**



Blue Code **CT6/BL**



Clear Code **CT6/CL**



Mixed Code **CT6/TM**
2 blue + 2 red + 2 yellow



Pack of 3 Code **CW3**
£60.56

Wicker baskets

Traditional wicker baskets sold in packs of 3

Junior Products - Partition Screens

Wood Mobile Noticeboard/Dividers

A range of premium handmade beech framed boards.
 Double sided boards available in 3 sizes of loop nylon faced noticeboard or drywipe whiteboard.
 Heavy duty frame made from quality lacquered beech sourced from sustainable forests.
 Edges of the board are rounded for increased safety.
 Heavy duty wooden feet ensure stability when freestanding; wheels are provided if mobility is required.
 Pinnable versions are covered in either Red or Blue loop nylon material.
 Whiteboard versions are double sided and have Guideline® gridded surface one side and plain on the reverse.

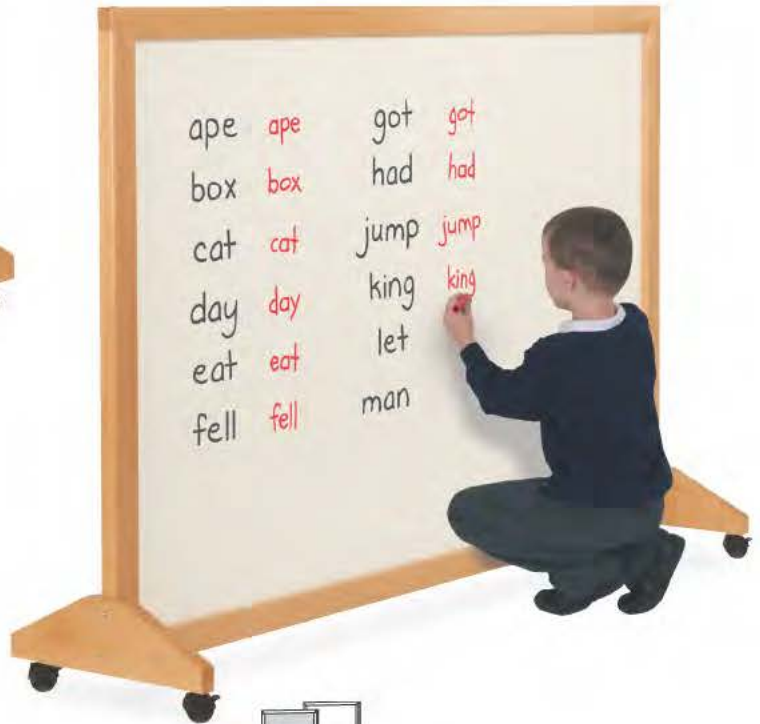

Size	H 1200mm		
	W 1200mm		
Blue	DJS44/BL	£317.50	
Red	DJS44/RD	£317.50	
Whiteboard	DJS44/WB	£310.00	



Size	H 1200mm		
	W 1800mm		
Blue	DJS46/BL	£365.97	
Red	DJS46/RD	£365.97	
Whiteboard	DJS46/WB	£363.06	



Size	H 1800mm		
	W 1200mm		
Blue	DJS64/BL	£365.97	
Red	DJS64/RD	£365.97	
Whiteboard	DJS64/WB	£363.06	

Junior Products - Partition Screens



BusyScreen® Curve Junior Divider Screens



A modern range of 32mm thick partition screens that feature rounded upper corners and a rounded edge trim.

Available in a range of 6 sizes

The foot design prevents twisting and fits securely into the base of each screen.

Each screen is supplied with two stabilising feet.

A range of 11 hard wearing woven cloth options.

Also available in a wide range of 18 loop nylon colours which accept Velcro® coins for displaying artwork, posters etc.

TO ORDER:

Please state the product code followed by the fabric colour code required.

EXAMPLE:

Divider screen 1600 x 1200mm in magenta = **BA1612/MG**

Optional castor feet available in lieu of stabiliser feet. See page 162

					
Size H 900mm W 1000mm	Size H 1200mm W 1000mm	Size H 1200mm W 1200mm	Size H 1200mm W 1600mm	Size H 1450mm W 1200mm	Size H 1600mm W 1200mm
Code BA9010 £140.00	Code BA1210 £159.82	Code BA1212 £168.77	Code BA1216 £177.02	Code BA1412 £176.14	Code BA1612 £172.46

Woven cloth colours with Black trim.



Traditional loop nylon cloth colours supplied with Black trim.



New loop nylon cloth colours with Grey trim.



Index

3 Tier Desktop Leaflet Dispensers **111**
 4 Sided Revolving Leaflet Dispensers
 Vibrant Colours **106**
 Standard **106**

A

A Frames **92-93**
 A4 Brochure Stand **107**
 Acrylic Top Lecterns **155**
 All Clear Leaflet Dispensers **108**
 All Clear Premier Leaflet Dispensers **109**
 Aluminium Framed Noticeboards
 ColourPlus® Felt **50-51**
 Cork **50-51**
 Dual **62-63**
 Eco-Colour® **52-53**
 Felt **50-51**
 Fire Retardant **52-53**
 Fire Retardant Cloth **68**
 Freestanding **83-85**
 Resist-a-Flame® **52-53**
 Woven Cloth **52-53**
 Art Easels **185-186**
 Audio Visual Furniture
 Column 125 Projector Trolley **157**
 Folding Projector Stand **157**
 MM100 Projector Cabinet **159**
 MM80 Projector Cabinet **158**
 MM90 Projector Cabinet **158**
 Secure TV Stand **156**
 Secure MM Projector Trolley **157**

B

Barrier Systems
 Retractable **137**
 Rope and Pole **137**
 Bigbook Easels
 Desk Easel **183**
 Storage Easel **183**
 Brochure Stacker **112-113**
 BusyFix® Coins for Display Systems **131**
 BusyFold® Display System
 Heavy Duty **126,128-131**
 Heavy Duty Plinths **131**
 Heavy Duty Tabletop **126**
 Light 1800 **131**
 Light Display **127-131**
 Light Tabletop **127**
 Light Tabletop XL **127**
 Light XL **127-130**
 BusyGrip® **86-93**
 BusyRail® System **44-45**
 BusyScreen® Partitions
 Accessories **142**
 Classic **140-142**
 Curve **138-139**
 Triple Safety **142**
 Buzzard Easel **38**

C

Certificate Frames **88**
 Chalkboards
 A Frames **92-93,95**
 Art Easels **185**
 Freestanding **92-93,95**
 Wall Mounted **96-97**
 Chairs
 Break Out **152**
 Conference **152**
 Cinco Leaflet Dispensers **115**
 Clocks
 Big Clock **145**
 Coloured **145**
 Giant Clock **145**
 LED Clock **145**
 World **145**
 Coat Hooks
 Brushed Steel **143**
 Mesh **143**
 Coat Rails **144**

Coat Stands **143**
 ColourBox® Storage Furniture
 Cloakroom Unit **205**
 Colour Swatches **193**
 Coloured Tubs **198**
 Cubby Hole Units **198-199**
 Deep Tray Units **195**
 Deep Trays **197**
 General Purpose Unit **201**
 How to Order **192**
 Kinderbox Units **200-201**
 Mix and Match Tray Units **196**
 Quadrant Shelving Units **204**
 Quadrant Tub Units **204**
 Shallow Tray Units **194**
 Shallow Trays **197**
 Shelf Cabinets **202**
 Static Large Cabinet **203**
 Stepped Unit **199**
 Tub Cabinets **200-202**
 Tub Units **198-199,205**
 Wicker Baskets **205**
 Colour Edged Whiteboards **10-11**
 ColourPlus Noticeboards
 Aluminium Framed **50-51**
 EF EcoFriendly® **54-55**
 Frameless **46-47**
 Lockable **64-65**
 Coloured Frame Whiteboards **19-21**
 Column 125 Projector Trolley **157**
 Combi Mobile Easel **39,95**
 Conference Pro Easel **39**
 Covered Noticeboards **64-82**
 Crest Leaflet Dispensers
 Freestanding **110**
 Wall Mounted **110**
 Cygnet Easel **39**

D

Desk Easels **183**
 Display Cases **146-147**
 Dressing Up Unit **187**
 Drywipe Boards **6-32**
 Drywipe Maps **30-31**
 Drywipe Pens and Accessories **33**
 Dual Faced Whiteboards **10-13,16-18,22-25**
 Dual Noticeboards
 Aluminium Framed **62-63**
 Combi Mobile **85**
 Cork **62-63**
 Eco-Friendly **62**

E

Eco-friendly Noticeboards
 Contrast **56**
 Cork **54-55**
 Dual **62-63**
 Eco-Colour® **56**
 Felt **54-55**
 ColourPlus **55**
 Eco-friendly Whiteboards **19**
 Eco-premier Noticeboards
 Cork **57**
 Felt **57**
 Electric Plug and Play Projection Screens **168**
 Exhibition Systems
 Accessories **131**
 BusyFix® Coins **131**
 BusyFold® Heavy Duty **126,128-131**
 BusyFold® Heavy Duty Plinths **131**
 BusyFold® Heavy Duty Tabletop **126**
 BusyFold® Light **127-131**
 BusyFold® Light 1800 **131**
 BusyFold® Light Tabletop **127**
 BusyFold® Light Tabletop XL **127**
 BusyFold® Light XL **127-130**
 Folding **126-131**
 Grandstand **135**
 Leaflet Holder **131**
 MightyBoard Display **132**

Exhibition Systems cont.
 MightyBoard Exhibitor **133**
 MultiBoard **136**
 OnBoard **134**
 Pole and Panel **132-136**
 Tabletops **126-127**
 Eyeline® Electrically Operated Projection Screens
 Eyeline® Design **168**
 Key Switch **176**
 Large Borderless **172**
 Max **173**
 Pro Channel Fix **169**
 Rollfix Heavy Duty **170**
 Rollfix In-ceiling Recess Frame **171**
 Rear Projection **175**
 Remote Controls **176**
 Wave Tab Tension **174**
 Eyeline® Fixed Frame Screen **177**
 Eyeline® Manually Operated Projection Screens
 Wall Screens **166**
 Eyeline Design **167**
 Eyeline® Portable Projection Screens
 Floor Screen **162,163**
 SpeedyFold **164**
 Movielux **163**
 Tripod Screens **161**
 Vertigo Scissor Action **163**
 Eyeline® Projection Whiteboards **178-181**

F

Fire Retardant Cloth Noticeboards
 Aluminium Framed **68**
 Lockable **68**
 Flipchart Easels
 BusyRail® **44-45**
 Buzzard **38**
 Combi Mobile **39**
 Conference Pro **39**
 Cygnet **39**
 Flipchart Pads **42**
 Flipchart Pens **42**
 Flip Pad Holder **15,37**
 Glass **7**
 Hawk **39**
 Trapease® **43**
 Tripod **39**
 Ultimate Loop Leg **40-41**
 Ultimate Mobile **41**
 Floor Projection Screens
 Folding Display **126-131**
 Folding Lecterns **153**
 Folding Projector Stand **157**
 Folding Whiteboards **18**
 Foyer Whiteboard Stands **26**
 Frame Projection Screens **177**
 Frameless Noticeboards
 ColourPlus **46-47**
 EcoColour® **48-49**
 Felt **46-47**
 Resist-a-Flame® **48-49**
 Woven Cloth **48-49**
 Frameless Whiteboards **6,10-15**
 Freestanding Noticeboards **82-85**
 Freestanding Whiteboards **22-26**

G

Glass Information Boards **97**
 Glass Whiteboards **6-9**
 Glazed Display Cases
 Freestanding **146-147**
 Wall Mounted **146-147**
 Gridded Whiteboards **27**
 Gridding Tape **33,36**

H

Handheld Whiteboards **32**
 Handwriting Whiteboards **27**
 Hawk Easel **39**

I

In-Out Boards **98-99**
 In-Out Whiteboards **31,99**

J

Junior Products
 Art Easels **185-186**
 Bigbook Desk Easel **183**
 BusyScreen® Round Corner Screens **207**
 Desk Easels **183**
 Junior Bigbook Storage Easel **183**
 Junior mobile Tilting Whiteboard **184**
 Junior Products cont.
 Roll Play **187-189**
 Trapease® Paper Hanger **186**
 Wood Mobile Noticeboards **206**
 WriteOn® Laptop Whiteboards **182**
 Junior Storage Furniture **190-205**

K

Kitchen **187**

L

Laptop Whiteboards
 Colour Frame **182**
 Frameless **182**
 Sportsboards **32**
 Large Format Projection Screens **164,172-174**
 Leaflet Display
 3 Tier Desktop **111**
 4 Sided Revolving **106**
 A4 brochure Stand **107**
 Acrylic **104-114**
 All Clear **108**
 All Clear Premier **109**
 Brochure Stacker **112-113**
 BusyRail® **44-45**
 Cinco **115**
 Crest **110**
 Mahogany **125**
 Mesh **118-119**
 Oak **124-125**
 Oak Deluxe **124**
 Panorama **104-105**
 Pirouette **107**
 Quatro **115**
 Revolving **106-107,111,118,120,123,125**
 Revolving Desktop **111,120**
 Shelf Style **112-115**
 Single Pocket **107**
 Steel **120-121**
 Tabletop **109,111,119,122**
 Wave **116-117**
 Wire **122-123**
 Wooden **124-125**
 Leaflet Holder for Display Systems **107**

M

Lecterns
 Acrylic Top **155**
 Folding **153**
 Panel Front **154-155**
 Tabletop **153**
 Lined Whiteboards **27**
 Literature Display **104-125**
 Lockable Noticeboards **64-82**

M

Magnetic Whiteboards **14,16-17,21**
 Magnets **36**
 Mahogany Leaflet Dispensers **125**
 Manual Wall Projection Screens **166-167**
 Maps **30-31**
 Meeting Room Essentials
 Chairs **152**
 Clocks **145**
 Coat Hooks **143**
 Coat Rails **144**
 Coat Stands **143**
 Glazed Display Cabinets **146-147**
 Tables **148-151**

